

Datasheet

Passive MUX/DeMUX Cables

Two-wavelength, one fiber to two fibers



Highlights

- 2-wavelength Mux/DeMUX cable separates and combines wavelengths
 - 1310 nm / 1550 nm
 - CWDM
 - DWDM
- Single-mode fiber
- Low return loss and cross-talk
- High isolation
- Low polarization dependency
- Environmentally stable

Overview

A MUX/DeMUX cable combines and separates two optical signals on different wavelengths, potentially doubling the data capacity of the installed fiber plant. The single-fiber technology is bi-directional using gray (wide), CWDM, or DWDM wavelengths as specified by "/xxyy" in the ordering codes.

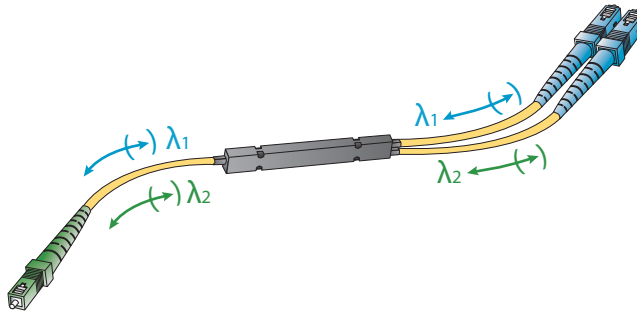

The single MUX end of the cable passes both wavelengths. The two-fiber DeMUX end separates each wavelength signal onto a dedicated fiber strand. Each wavelength passes in only one direction at a time to avoid confusion of signals, but the passive cable allows flow in either direction.

MUX/DeMUX cables are fully passive, and they operate at specific wavelengths. They are transparent to networks and protocols. A pair of cables, as in the example below, attenuates an optical signal by no more than 1.2 dB on either single-mode or multi-mode fiber. Signal reflections are effectively eliminated with angled polished connectors (APC) at the single-fiber MUX interface.

For additional information including availability and configuration options, contact your MRV Communication sales representative.

Datasheet

Linear Single Fiber Point-to-Multipoint

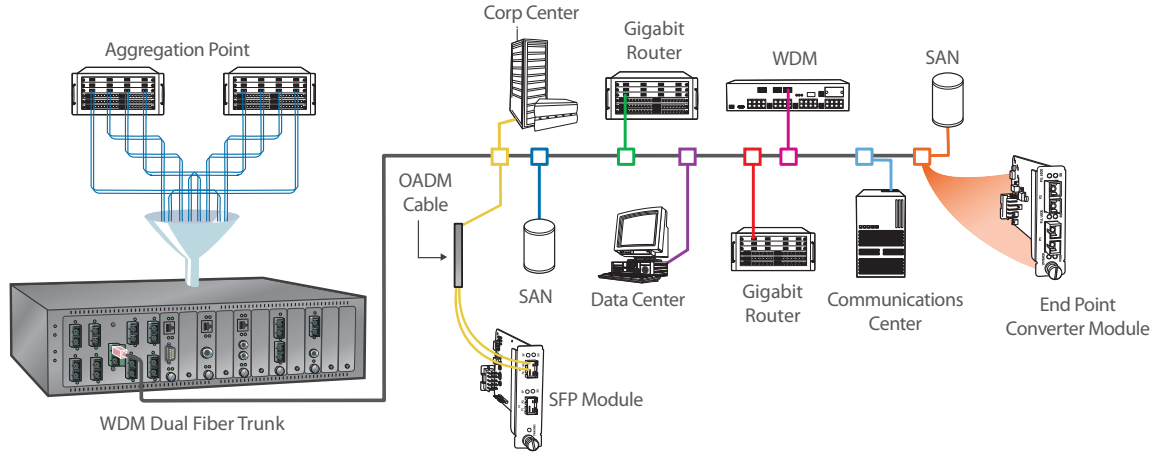

Physical Specifications

Model	PADWLCSC/xyxy or PADWSC/xyxy	PAWLCSC/xyxy or PAWSC/xyxy	PADMSYY/xx	PASCSC/3155	PALCSC/3155
Operating Wavelength, nm	xx/yy*	xx/yy*	1310 - 1610	1310/1550	1310/1550
Wavelength Tolerance, nm	± 0.1	± 6.5	± 6.5	± 40	± 40
Insertion Loss, dB	Typical	0.5	0.5	0.5	0.5
	Max	1.2	0.7	0.7	0.7
Passband Ripple, dB	≤ 0.3	≤ 0.3	≤ 0.3	≤ 0.3	≤ 0.3
Isolation, dB	From (C) to (P2) Channel	≥ 10	≥ 15	≥ 15	≥ 15
	From (C) to (P1) Channel	≥ 20	≥ 40	≥ 40	≥ 40
Optical Return Loss, dB	≥ 45	≥ 45	≥ 45	≥ 45	≥ 45
Directivity, dB	≥ 40	≥ 50	≥ 50	≥ 50	≥ 50
Thermal Stability, dB/°C	≤ 0.005	≤ 0.005	≤ 0.005	≤ 0.005	≤ 0.005
Polarization Dependent Loss, dB	≤ 0.1	≤ 0.1	≤ 0.05	≤ 0.05	≤ 0.05
Polarization Mode Dispersion (PMD), ps	≤ 0.1	≤ 0.1	≤ 0.1	≤ 0.1	≤ 0.1
Optical Power, mW	≤ 300	≤ 300	≤ 300	≤ 300	≤ 300
Tensile Load, N	≤ 5	≤ 5	≤ 5	≤ 5	≤ 5
Operating/Storage Temperature, °C	-40 to 85	-40 to 85	-40 to 85	-40 to 85	-40 to 85
Cable Length, m	1	1	0.5	0.5	0.5
Package Size, mm	Ø 5.5 x 34	Ø 5.5 x 34	Ø 5.5 x 34	Ø 5.5 x 34	Ø 5.5 x 34

*yy - All other wavelengths

PASSIVE DWDM CABLES

Ordering Information

Model	Description	Connectors Port/Link	Wavelength* (nm)	Insertion Loss (dB)
PADWSC/xyxy	Passive 2 Wavelength DWDM Cable, Single Fiber SM	SC (x2) / SC	xx/yy ±0.1	1.2
PADWLCSC/xyxy	Passive 2 Wavelength DWDM Cable, Single Fiber SM	LC (x2) / SC	xx/yy ±0.1	1.2

* See DWDM Wavelength Chart below



Datasheet

DWDM Wavelengths

ITU Channel (xx or yy)	Wavelength (nm)	ITU Channel (xx or yy)	Wavelength (nm)	ITU Channel (xx or yy)	Wavelength (nm)	ITU Channel (xx or yy)	Wavelength (nm)
21	1560.61	31	1552.52	41	1544.53	51	1536.61
22	1559.79	32	1551.72	42	1543.73	52	1535.82
23	1558.98	33	1550.92	43	1542.94	53	1535.04
24	1558.17	34	1550.12	44	1542.14	54	1534.25
25	1557.36	35	1549.32	45	1541.35	55	1533.47
26	1556.56	36	1548.52	46	1540.56	56	1532.68
27	1555.75	37	1547.72	47	1539.77	57	1531.90
28	1554.94	38	1546.92	48	1538.98	58	1531.12
29	1554.13	39	1546.12	49	1538.19	59	1530.33
30	1553.33	40	1545.32	50	1537.40	60	1529.55

PASSIVE CWDM CABLES

Ordering Information

Model	Description	Connectors Port/Link	Wavelength* (nm)	Insertion Loss (dB)
PAWSC/xxyy	Passive 2 Wavelength (xx\yy) Cable, Single Fiber SM	SC (x2) / SC	xx/yy ±6.5	0.7
PAWLSC/xxyy	Passive 2 Wavelength (xx\yy) Cable, Single Fiber SM	LC (x2) / SC	xx/yy ±6.5	0.7
PADMSYY/xx	Passive 2 Wavelength (xx\yy) Cable, Single Fiber SM	Defined by YY (MU, LC or SC)	xx ±6.5	0.7
PASCSC/3155	Cable, Protocol Independent Single Fiber SC Add/Drop	SC (x2) / SC	1310/1550 ± 40	0.7
PALCSC/3155	Cable, Protocol Independent Single Fiber LC Add/Drop	LC (x2) / SC	1310/1550 ± 40	0.7

* See the CWDM table below for wavelengths

CWDM Wavelengths

xx or yy	Wavelength	xx or yy	Wavelength	xx or yy	Wavelength	xx or yy	Wavelength
31	1310 nm	39	1390 nm	47	1470 nm	55	1550 nm
33	1330 nm	41	1410 nm	49	1490 nm	57	1570 nm
35	1350 nm	43	1430 nm	51	1510 nm	59	1590 nm
37	1370 nm	45	1450 nm	53	1530 nm	61	1610 nm

MRV has more than 50 offices throughout the world. Addresses, phone numbers and fax numbers are listed at www.mrv.com. Please e-mail us at info@mrv.com or call us for assistance.

MRV Los Angeles
20415 Nordhoff Street
Chatsworth, CA 91311
800-338-5316
818-773-0900

MRV Boston
300 Apollo Drive
Chelmsford, MA 01824
800-338-5316
978-674-6800

MRV International
Business Park Moerfelden
Waldeckerstrasse 13
64546 Moerfelden-Walldorf
Germany
Tel. (49) 6105/2070
Fax (49) 6105/207-100

All statements, technical information, and recommendations related to the products herein are based upon information believed to be reliable or accurate. However, the accuracy or completeness thereof is not guaranteed, and no responsibility is assumed for any inaccuracies. Please contact MRV Communications for more information. MRV Communications and the MRV Communications logo are trademarks of MRV Communications, Inc. Other trademarks are the property of their respective holders.