

Datasheet

LambdaDriver® 10 Gbps Transponder Module (TM-DXFP)

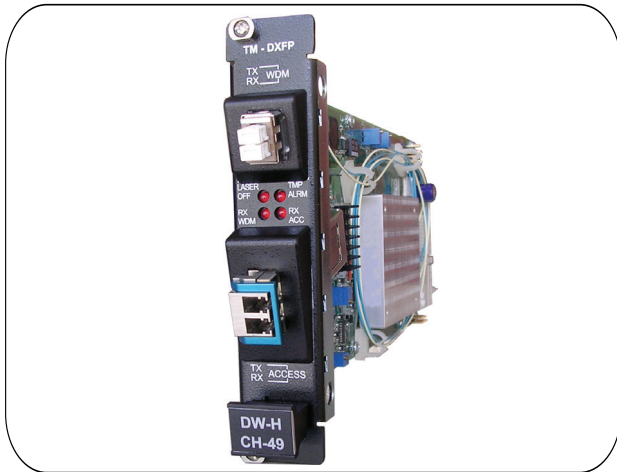

10Gbps transponder

Overview

The TM-DXFP transponder is a single slot module that converts the “gray” wavelength of a 10 Gbps terminal equipment interface to an ITU-T grid DWDM wavelength enabling its transport via the LambdaDriver® Optical Transport System (DWDM multiplexer, OADM etc.)

The TM-DXFP module supports OC-192/STM64 and 10 GbE protocols with 3R signal conditioning.

The access (terminal equipment) interface is an XFP (10 Gbps Small Form Factor Pluggables receptacle), while the trunk (DWDM) port is an integrated 50GHz tunable DWDM interface.

Automatic Laser Shutdown (ALS) feature automatically reduces the optical power of the transmitters to an eye safe level in case of a broken link. The ALS feature is implemented on both ports of the transponders (DWDM side and Terminal equipment side). Remote and Local Loop-back functionality is supported and serves as an invaluable tool for troubleshooting and maintenance operations in a live network.

Features

- 10 Gbps LAN or WAN transport
- Full 3R support
- Remote and Local Loop-back testing
- 50GHz spacing ITU-grid(G.694.1) DWDM Trunk
- Dispersion tolerance up to 200 km
- XFP digital diagnostics
- Link Integrity notification (LIN)
- Y-Cable protection support
- Automatic Laser Shutdown (ALS)
- Hot swappable

Applications

- 10 GE or SDH/SONET distance extension and repeaters
- 10Gbps signal regeneration and optical wavelength conversion
- Data rate upgrade of existing DWDM networks to 10 Gbps

The Link Integrity Notification (LIN) function allows the terminal equipment to detect the link failure in the path between the two terminal equipment units, regardless of the location of the failure.

The TM-DXFP transponders provide power monitoring of the trunk (DWDM) port in addition to Digital Diagnostics provided by the XFP of the access port.

The TM-DXFP transponders also support the Y-Cable based fast switch-over protection protocol. In this protection mode two adjacent transponders in a LambdaDriver® chassis run a protocol that maintains “operational” and “standby” transponders for a single 10Gbps port of an access device.

The modules are manageable with the LambdaDriver management module either locally using RS232 CLI access or remotely using Telnet in SNMP, for example, with MRV’s MegaVision Pro NMS.

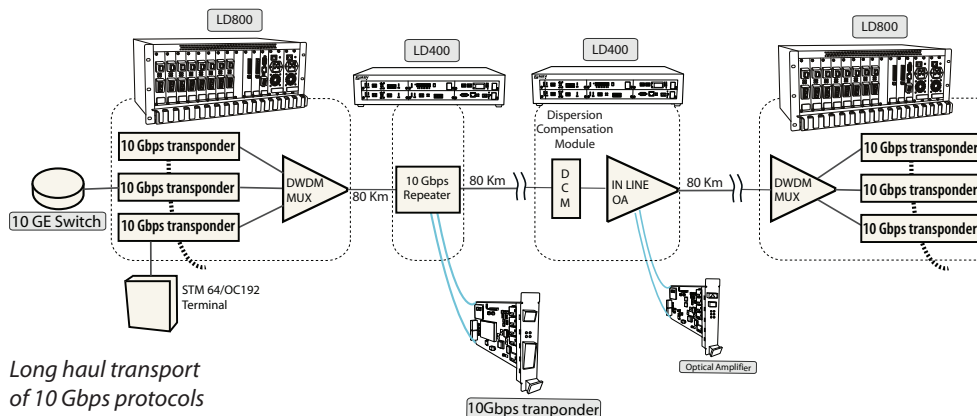

Long haul transport of 10 Gbps protocols

Environmental

Operating Temperature	- 5 to 45 °C (23 °F to 113 °F)	
Storage Temperature	-10 to 70 °C (14 °F to 158 °F)	
Relative Humidity	85% maximum, non-condensing	
Dimensions (W x H x D)	26.93 x 130.7 x 227 mm (1.06 x 5.145 x 8.93 in)	
Weight	0.700 kg (1.54 lb)	
Connector	Mini SC (MU) - WDM port; XFP access port	
Power consumption	Module	XFP
	15.3W	3.5W

Technical Specifications

WDM TX power (dBm)	4 -7
Maximum receiver sensitivity (dBm)	-24
Overload (dBm)	- 8
DWDM wavelengths range	1528 - 1561nm on ITU-T G694.1 50Ghz grid
Wavelengths Accuracy	+/-10pm
Wavelengths Tuning Time - cold start (sec)	30
Wavelengths Tuning Time - warmed - up (sec)	0.5
Chromatic Dispersion tolerance at 1525nm - 1570nm	1600 ps/nm
Dispersion penalty at limit (dB)	2

Order Info

Product	Description
TM-DXFP8T	10Gbps DWDM tunable wavelength transponder up to 80 Km distance, XFP Access port.

All statements, technical information and recommendations related to the products herein are based upon information believed to be reliable or accurate. However, the accuracy or completeness thereof is not guaranteed, and no responsibility is assumed for any inaccuracies. Please contact MRV Communications for more information. MRV Communications and the MRV Communications logo are trademarks of MRV Communications, Inc. Other trademarks are the property of their respective holders.