

Datasheet

# LambdaDriver® - Multi-rate Module (TM2-SFPXC)



TM2-SFPXC

**Features**

- High port density – 2 transponders per slot
- Use of SFP transceivers on all ports
- Up to 4.25 Gbps data rates
- LIN (Link Integrity Notification) mechanism
- Line loop-back per port
- SFP digital diagnostics monitoring
- Hot swappable
- Cross connect functionality

**Applications**

- Up to 4.25 Gbps signal regeneration and optical wavelength conversion
- Video Distribution

**Overview**

The TM2-SFPXC is a single slot module incorporating two independent transponders. Each of the four port can be fitted with an SFP transceiver from any standard type – MM, SM, CWDM, DWDM or copper. The main differences between this module and previous versions of this type of transponder is an on-board Cross-Connect functionality that allows a higher level of flexibility in port configuration.

The TM2-SFPXC supports various data rates of up to 4.25 Gbps. All popular protocols are supported, including Ethernet, SONET/SDH, OTU1, Fiber Channel, ESCON, FICON, Digital Video (SDI, HD-SDI, 3G-SDI). Each transponder has a separate data rate selection function. Data rate selection can be done by Software with the LambdaDriver management module or by DIP switch setting when no management module present. Each transponder supports 3R data conditioning for 100Mbps and higher rates or 2R transparent operation for all rates.

The Automatic Laser Shutdown (ALS) feature automatically reduces the optical power of the transmitters to an eye safe level in case of a broken link. The ALS feature is implemented on both ports of the transponder (DWDM trunk and Terminal equipment access port).

It supports loop-back functionality per port and provides an invaluable tool for troubleshooting and maintenance operations in

a live network.

The Link Integrity Notification (LIN) function allows the terminal equipment to detect a link failure in the path between the two end-nodes, regardless of the location of the failure.

The TM2-SFPXC transponders also support the Y-Cable based fast switchover protection protocol with two options of operation:

1. Protection between two transponders in a single module. In this mode, the Y-cable is connected between two "access" ports to provide protection between the two transponders on the same module. In this mode the protection is done with minimal space and power consumption.
2. Two separate modules to work in protection mode. In this protection mode, two adjacent transponders in the a LambdaDriver® chassis run a protocol that maintains "operational" and "standby" transponders for a port of an access device.

The Y-cables are connected between appropriate ports on different modules. This provides the highest level of protection due to the fact that during failure maintenance module replacement, there is no influence on the service running in the "operational" path. The Cross-Connection functionality of the module allows

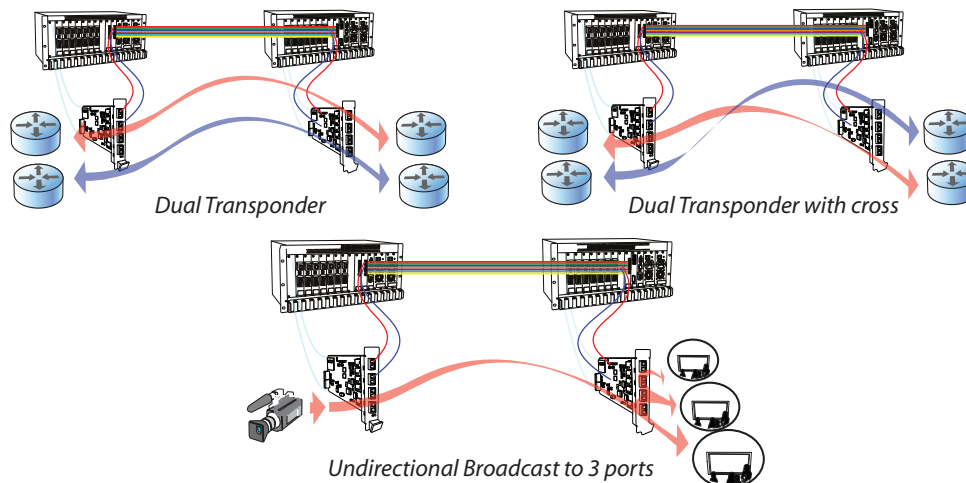

besides the normal “dual transponder” mode, two additional configurations:

1. Two cross-over. This option allows remote ports swap action for maintenance testing or service redirection.
2. Unidirectional Broadcast from one port to three others. This configuration may be used in Video distribution applications.

The modules are manageable with the LambdaDriver management module either locally by RS-232 CLI access or remotely by Telnet, SNMP or MRV's MegaVision Pro NMS platform.

### Environmental

<b>Operating Temperature</b>	- 5 to 45°C (23°F to 113°F)
<b>Storage Temperature</b>	-10 to 70°C (14°F to 158°F)
<b>Relative Humidity</b>	85% maximum, non-condensing
<b>Dimensions (W x H x D)</b>	26.93 x 130.7 x 227 mm (1.06 x 5.145 x 8.956 in)
<b>Weight</b>	1.21kg (0.550 lb)
<b>Connector</b>	SFP sockets all ports
<b>Power consumption</b>	Module: 5.38W                      SFP: 1W

### Technical Specifications

<b>Data rates</b>	8Mbps to 4.25Gbps
<b>Optical parameters</b>	Per the SFP

### Order Info

**TM2-SFPXC**      SFP-based dual transponder, any rate (8Mbps - 4.25 Gbps) with cross connection functionality

All statements, technical information and recommendations related to the products herein are based upon information believed to be reliable or accurate. However, the accuracy or completeness thereof is not guaranteed, and no responsibility is assumed for any inaccuracies. Please contact MRV Communications for more information. MRV Communications and the MRV Communications logo are trademarks of MRV Communications, Inc. Other trademarks are the property of their respective holders.