

Datasheet

10 Gbps Multi-Rate Single Fiber Bidirectional SFP+ Transceivers

SFP-10GD-BX23 and SFP-10GD-BX32



Highlights

- SFP transceiver
- Data Rates: 9.953 -11.09 Gbps
- Protocols:
 - 10 Gigabit Ethernet
 - 10 Gigabit Fibre Channel
 - OC-192/STM-64
- Single-mode fiber
- Single fiber, bi-directional
- Two wavelengths:
 - 1270 nm and 1330 nm
- 0 to 10 km
- Simplex LC connector
- Digital Diagnostics (SFF-8472)
- Hot-swap

Overview

Small Form-Factor Pluggable (SFP) interfaces from MRV Communications provide flexible high speed links in a small industry standard package. They deliver the deployment options and inventory control that network administrators demand for growing networks.

SFPs are designed to Multi-Source Agreement (MSA) standards to ensure network equipment compatibility. They are a perfect addition to MRV's extensive lines of networking equipment.

Visit the MRV website at www.mrv.com or contact your nearest authorized MRV Communications dealer for more information.

Specifications Overview

Data Rate		9.953 -11.09 Gbps
Tx Wavelength:	SFP-10GD-BX23	1270 nm
	SFP-10GD-BX32	1330 nm
Launch Power in OMA minus TDP		-6.2 dBm
Optical Modulation Amplitude		-5.2 dBm
Tx Disable		Yes
Rx Wavelength:	SFP-10GD-BX23	1320 to 1340 nm
	SFP-10GD-BX32	1260 to 1280 nm
Rx Sensitivity in OMA		-12.6 dBm
Operating Temperature Range		-5 to 70 °C
Power Consumption		1 Watt

Datasheet

Transmitter Specifications (Optical)

Parameter	Symbol	Min	Max	Unit	Notes
Optical Power	P _{Op}	-8.2	0.5	dBm	-
Optical Crosstalk	XT	-	-30	dB	-
Average Launch Power Tx_Off	P _{Off}	-	-30	dBm	-
Extinction Ratio	ER	3.5	-	dB	-
Eye Mask	Compliant with IEEE 802.3				
Wavelength for SFP-GD-BX23	λ	1260	1280	nm	-
Wavelength for SFP-GD-BX32	λ	1320	1340	nm	-
Side Mode Suppress Ratio	SMSR	30	-	dB	-
RIN ₁₂ OMA	RIN	-	-128	dB/Hz	-
Optical Modulation Amplitude	OMA	-5.2	-	dBm	-
Launch Power in OMA minus TDP	OMA-TDP	-6.2	-	dBm	-
Transmitter and Dispersion Penalty	TDP	-	3.2	dB	-
Optical Return Loss Tolerance	ORLT	-	12	dB	-
Transmitter Reflectance	-	-	-12	dB	-

Receiver Specifications (Optical)

Parameter	Symbol	Min	Max	Unit	Notes
Average Receiver Power	-	-14.4	0.5	dBm	1
Receiver Sensitivity in OMA	-	-	0.055(-12.6)	mW(dBm)	2
Wavelength for SFP-GD-BX23	λ	1320	1340	nm	-
Wavelength for SFP-GD-BX32	λ	1260	1280	nm	-
Damage Threshold For Receiver	P _{in, damage}	-	4	dBm	-
Receiver Total Jitter	TJ	-	0.70	UI	-
Receiver Deterministic Jitter	DJ	-	0.42	UI	-
Vertical Eye Closure Penalty	-	2.2	-	dBm	-
Receiver Reflectance	RX _r	-	-12	dB	-
LOS Assert	-	-30	-	dBm	-
LOS De-assert	-	-	-14.4	dBm	-
LOS Hysteresis	-	0.5	-	dB	-

- Notes:**
1. Average Receiver Power (Min) is informative and not the principal indicator of signal strength. A received power below this value cannot be compliant.
 2. Measured with a PRBS 2³¹-1 test pattern @10.3125Gbps, BER ≤ 10⁻¹²

Digital Diagnostics

Parameter	Range	Accuracy	Unit	Calibration	Formula
Temperature	-5 to 70	± 3	° C	External	Tc(C) = Tslope* <i>T</i> ad(16 bit signed twos complement value) + Toffset
Voltage	0 to V _{CC}	0.1	V	External	V(Volts) = Vslope* <i>V</i> ad (16 bit unsigned integer) + Voffset
Bias Current	0 to 120	5	mA	External	I(mA) = Islope * Iad(16 bit unsigned integer) + Ioffset
TX Power	-8.2 to 0.5	±3 dB	dBm	External	Tx_PWR(μW) = Tx_PWRslope*Tx_PWRad (16 bit unsigned integer) + Tx_PWRoffset
RX Power	-14.4 to 0.5	±3 dB	dBm	External	RX_PWR(μW)=A0+A1*x+A2*x^2+A3*x^3+A4*x^4

Datasheet

Absolute Maximum Ratings

Parameter	Symbol	Min.	Max.	Unit	Notes
Storage Temperature	T_S	-40	85	°C	-
Supply Voltage	V_{CC}	-0.5	4.0	V	-
Operating Relative Humidity	RH	-	85	%	-

Recommended Operating Conditions

Parameter	Symbol	Min.	Max.	Unit	Notes
Supply Voltage	V_{CC}	3.14	3.46	V	-
Total Current	I_{CC}	-	300	mA	-
Maximum Power Dissipation	P_{VCC}	-	1	W	-
Inrush Current	$I_{IN-RUSH}$	-	30	mA	1
Power Supply Noise Rejection	PSR	66/99	-	mV _{p-p}	2
Storage Temperature	T_{opr}	-5	70	°C	-
Data Rate	DR	9.953	11.09	Gbps	3

- Notes:**
1. Max duration 500 ms
 2. 66 mV_{p-p}: 10Hz-1MHz, 2% p-p, 3.3V power supply. 99 mV_{p-p}: 1-10MHz, 3% p-p, 3.3V power supply.
 3. Supports 10GE at 9.953, 10.3125 and 11.09 Gbps, 10GFC at 10.51 Gbps. PRBS 2³¹-1.

Electrical Specifications and Timing

Parameter	Symbol	Min	Max	Unit	Notes
Input Differential Impedence	R_{in}	90	110	Ω	-
PECL Differential Data Input Swing	$V_{in, p-p}$	400	1600	mV	-
PECL Differential Data Output Swing	$V_{out, p-p}$	300	900	mV	-
Output Differential Impedence	R_{out}	80	120	Ω	-
Tx_Fault, RX_LOS	V_{OL}	0.0	0.4	V	-
	V_{OH}	Host_Vcc - 0.5	Host_Vcc + 0.3	V	-
Tx_Disable	V_{IL}	-0.3	0.8	V	-
	V_{IH}	2.0	VccT + 0.3	V	-
RS0, RS1	V_{IL}	-3.0	0.8	-	-
	V_{IH}	2.0	VccT + 0.3	-	-
Tx Disable Negate Time	t_{on}	-	2	ms	-
Tx Disable Assert Time	t_{off}	-	10	μ s	-
Time To Initialize 2-Wire Interface	$t_{2w_start_up}$	-	300	ms	-
Time To Initialize	t_{start_up}	-	300	ms	-
TX Fault Assert Time	t_{fault_on}	-	1	ms	-
TX Fault Reset	TX_Fault Reset	10	-	μ s	-
RX_LOS Assert Delay	t_{loss_on}	-	100	μ s	-
RX_LOS Negate Delay	t_{loss_off}	-	100	μ s	-

Datasheet

Pin	Function	Name / Description	Notes
1	V _{eeT}	Module Transmitter Ground	1
2	TX_FAULT	Module Transmitter Fault	2
3	TX_DISABLE	Transmitter Disable; Turns Off Transmitter Laser Output	3
4	SDL	2-Wire Serial Interface Data Line (MOD-DEF2)	-
5	SCL	2-Wire Serial Interface Clock (MOD-DEF1)	-
6	MOD_ABS	Module Absent, Connected to V _{eeT} or V _{eeR} in the Module	-
7	RS0	Rate Select 0 – Not in use	-
8	RX_LOS	Receiver Loss of Signal Indication (in FC Designated as RX_LOS, in SONET Designated as LOS, and in Ethernet Designated as NOT Signal Detect)	2
9	RS1	Rate Select 1 – Not in Use	-
10	V _{eeR}	Module Receiver Ground	1
11	V _{eeR}	Module Receiver Ground	1
12	RXD-	Receiver Inverted Data Output	-
13	RXD+	Receiver Non-Inverted Data Output	-
14	V _{eeR}	Module Receiver Ground	1
15	V _{ccR}	Module Receiver 3.3V Supply	-
16	V _{ccT}	Module Transmitter 3.3V Supply	-
17	V _{eeT}	Module Transmitter Ground	1
18	TXD+	Transmitter Non-Inverted Data Input	-
19	TXD-	Transmitter Inverted Data Input	-
20	V _{eeT}	Module Transmitter Ground	1

- Notes:**
1. The module ground pins, V_{eeR} and V_{eeT}, shall be isolated from the module case.
 2. This pin is an open collector/drain output pin and shall be pulled up with 4.7 K-10 K ohms to a Host V_{cc} on the host board.
 3. Shall be pulled up with 4.7 K-10 K ohms to V_{ccT} in the module.

Outline Drawing

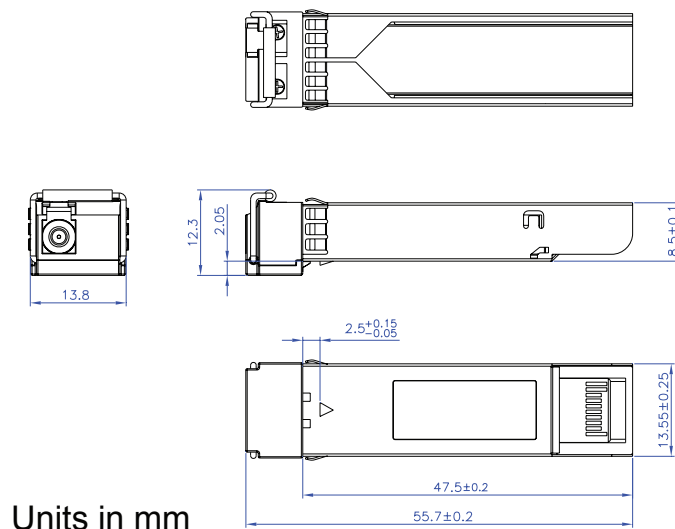

Datasheet

Ordering Information

Model	Description	Data Rate (Gbps)	Wavelength (nm)		Connector Type	Bail Latch Color	Distance Range (km)
			Tx	Rx			
SFP-10GD-BX23	SFP+ Bidirectional Transceiver Single Fiber, Single-Mode with Digital Diagnostics	9.953 - 11.09	1270	1330	Simplex LC	Gray	0-10
SFP-10GD-BX32	SFP+ Bidirectional Transceiver Single Fiber, Single-Mode with Digital Diagnostics	9.953 - 11.09	1330	1270	Simplex LC	Green	0-10

Regulatory and Industry Compliances

Class 1 Laser Product, complies with EN 60825-1 and 21 CFR 1040.10 except for deviations pursuant to Laser Notice No. 50. dated June 24, 2007
MSA SFF-8074i; Digital Diagnostic SFF-8472

Certified by one or more of the following agencies: TÜV, UL, CSA

RoHS Directive; China RoHS; California RoHS Law, REACH Directive SVHC; WEEE Directive

The Quality Management System is certified to ISO 9001 by QMI-SAI Global

The Environmental Management System is in compliance with ISO 14001

Warnings

Handling Precautions: This device is susceptible to damage as a result of electrostatic discharge (ESD). A static free environment is highly recommended. Follow guidelines according to proper ESD procedures.

Laser Safety: Radiation emitted by laser devices can be dangerous to human eyes. Avoid eye exposure to direct or indirect radiation.

MRV has offices throughout the world. Addresses, phone numbers and fax numbers are listed at www.mrv.com.
Please e-mail us at info@mrv.com or call us for assistance.

MRV Los Angeles
20415 Nordhoff Street
Chatsworth, CA 91311
800-338-5316
818-773-0900

MRV Boston
300 Apollo Drive
Chelmsford, MA 01824
800-338-5316
978-674-6800

MRV International
Business Park Moerfelden
Waldeckerstrasse 13
64546 Moerfelden-Walldorf
Germany
Tel. (49) 6105/2070
Fax (49) 6105/207-100

All statements, technical information, and recommendations related to the products herein are based upon information believed to be reliable or accurate. However, the accuracy or completeness thereof is not guaranteed, and no responsibility is assumed for any inaccuracies. Please contact MRV Communications for more information. MRV Communications and the MRV Communications logo are trademarks of MRV Communications, Inc. Other trademarks are the property of their respective holders.