

**Datasheet**

**10 Gbps 220 m Multi-Mode SFP+ Transceiver**

SFP-10GD-LRM



**Highlights**

- SFP+ transceiver
- Data Rates: 10.3125 Gbps
- Protocols:
  - 10 Gigabit Ethernet
- Multi-mode fiber
- 1310 nm
- 0 - 220 m
- Duplex LC connector
- Digital Diagnostics (SFF-8472)
- Hot-swap

**Overview**

Enhanced Small Form-Factor Pluggable (SFP) interfaces from MRV Communications provide flexible high speed links in a small industry standard package. They deliver the deployment options and inventory control that network administrators demand for growing networks.

SFPs are designed to Multi-Source Agreement (MSA) standards to ensure network equipment compatibility. They are a perfect addition to MRV’s extensive lines of networking equipment.

Visit the MRV website at [www.mrv.com](http://www.mrv.com) or contact your nearest authorized MRV Communications dealer for more information.

**Specifications Overview**

Data Rate	10.3125 Gbps
Tx Wavelength	1310 nm
Tx Power (Minimum) in OMA	-4.5 dBm
Tx Dispersion Penalty	4.7 dB
Tx Disable	Yes
Rx Wavelength	1260 - 1355 nm
Rx Sensitivity in OMA	-6.5 dBm
Rx Saturation in OMA	1.5 dBm
Operating Temperature Range	0 to 70 °C
Power Consumption	< 1.5 Watt

## Datasheet

### Optical Specifications

Parameter	Symbol	Minimum	Maximum	Unit	Note
Operating Data Rate	-	-	10.3125	Gbps	-
Centre Wavelength	$\lambda_c$	1260	1355	nm	-
<b>Transmitter</b>					
Launch Power in OMA	P <sub>OUT-OMA</sub>	-4.5	1.5	dBm	1
Average Launch Power	P <sub>OUT</sub>	-6.5	0.5	dBm	1
Average Launch Power of OFF Transmitter	P <sub>OUT-OFF</sub>	-	-30	dBm	1
Peak Launch Power	P <sub>OUT-PEAK</sub>	-	3.0	dBm	1
Spectral Width	$\Delta\lambda$	2.4	4	nm	2
Side-Mode Suppression Ratio	SMSR	30	-	dB	-
Extinction Ratio	ER	3.5	-	dB	3
Transmitter Waveform and Dispersion Penalty	TWDP	-	4.7	dB	4
Optical Eye Mask	-	Compliant with IEEE P802.3aq-2006 requirements			-
<b>Receiver</b>					
Stressed Sensitivity in OMA	P <sub>IN</sub>	-	-6.5	dBm	5
Stressed Sensitivity in OMA for symmetrical test	P <sub>IN</sub>	-	-6.0	dBm	5
Overload in OMA	P <sub>IN</sub>	1.5	-	dBm	5
Receiver Reflectance	-	-	-12	dB	-

- Notes:**
1. Measured at TP2, after MMF patch code.
  2. See Figure 68-3, IEEE P802aq-2006.
  3. Measured with a PRBS 2<sup>31</sup> - 1 test pattern @10.3125 Gbps.
  4. Measured with a PRBS 2<sup>9</sup>-1 test pattern @10.3125 Gbps, BER≤10<sup>-12</sup>.
  5. Measured with a PRBS 2<sup>31</sup>-1 test pattern @10.3125 Gbps, ER=3.5 dB, BER≤10<sup>-12</sup>.

### Digital Diagnostics

Parameter	Range	Accuracy	Unit	Calibration	Formula
Temperature	-5 to 70	± 3	°C	External	T <sub>c</sub> (C) = T <sub>slope</sub> *T <sub>ad</sub> (16 bit signed twos complement value) + T <sub>offset</sub>
Voltage	0 to V <sub>CC</sub>	0.1	V	External	V(Volts) = V <sub>slope</sub> *V <sub>ad</sub> (16 bit unsigned integer) + V <sub>offset</sub>
Bias Current	0 to 120	5	mA	External	I(mA) = I <sub>slope</sub> * I <sub>ad</sub> (16 bit unsigned integer) + I <sub>offset</sub>
TX Power	-8.2 to 0.5	±3 dB	dBm	External	Tx_PWR(μW) = Tx_PWR <sub>slope</sub> *Tx_PWR <sub>ad</sub> (16 bit unsigned integer) + Tx_PWR <sub>offset</sub>
RX Power	-14.4 to 0.5	±3 dB	dBm	External	RX_PWR(μW)=A0+A1*x+A2*x^2+A3*x^3+A4*x^4

### Recommended Operating Conditions

Parameter	Symbol	Minimum	Maximum	Unit	Note
Operating Case Temperature	T <sub>C</sub>	0	70	°C	-
Power Supply Voltage	V <sub>CC</sub>	3.15	3.45	V	-
Power Supply Current	I <sub>CC</sub>	-	450	mA	-
Power Dissipation	PD	-	1.5	W	-
Data Rate	-	-	10.3125	Gbps	-
Transmission Distance	-	-	220	m	1

- Notes:**
1. See Table 68-2, IEEE P802aq-2006.

## Datasheet

### Absolute Maximum Ratings\*

Parameter	Symbol	Minimum	Maximum	Unit	Note
Storage Temperature	$T_S$	-40	85	°C	-
Supply Voltage	$V_{CC}$	-0.5	4.0	V	-
Operating Relative Humidity	RH	0	85	%	-

\*Exceeding the limits listed in the table may damage the transceiver module permanently

### Electrical Specifications

Parameter	Symbol	Minimum	Maximum	Unit	Note
<b>High-speed Signal Interface Specification</b>					
Differential Data Input Amplitude	-	400	1600	mVpp	-
Input Differential Impedance	-	80	120	$\Omega$	-
Differential Data Output Amplitude	-	250	580	mVpp	-
Output Differential Impedance	-	80	120	$\Omega$	-
<b>Low-speed Signal (LVTTTL) Interface Specification</b>					
Input High Voltage	-	2.0	3.3	V	-
Input Low Voltage	-	GND	0.8	V	-
Output High Voltage	-	2.4	3.3	V	-
Output Low Voltage	-	GND	0.4	V	-
<b>2 Wire Serial Interface (LVTTTL) Specification</b>					
Clock Frequency	$f_{SCL}$	-	100	KHz	-

### Diagram of Host Board Connector Block Pin Numbers and Names



## Datasheet

### Pin Descriptions

Pin	Logic	Symbol	Name/Description	Note
1	-	VeeT	Module Transmitter Ground	1
2	LVTTTL-O	TX_Fault	Module Transmitter Fault	2
3	LVTTTL-I	TX_Disable	Transmitter Disable; Turns off transmitter laser output	3
4	LVTTTL-O/I	SDL	2-Wire Serial Interface Data Line (MOD-DEF2)	-
5	LVTTTL-O/I	SCL	2-Wire Serial Interface Clock (MOD-DEF1)	-
6	-	MOD_ABS	Module Absent, connected to VeeT or VeeR in the module	3
7	LVTTTL-I	RS0	Rate Select 0, optionally controls SFP+ module receiver as the following when HIGH input data rate > 4.25 Gbps and when LOW input data rate ≤ 4.25 Gbps.	-
8	LVTTTL-O	RX_LOS	Receiver Loss of Signal Indication (in FC designated as RX_LOS, in SONET designated as LOS, and in Ethernet designated as NOT Signal Detect)	2
9	LVTTTL-I	RS1	Rate Select 1, optionally controls SFP+ module transmitter as the following when HIGH input data rate > 4.25 Gbps and when LOW input data rate ≤ 4.25 Gbps.	-
10	-	VeeR	Module Receiver Ground	1
11	-	VeeR	Module Receiver Ground	1
12	CML-O	RD-	Receiver Inverted Data Output	-
13	CML-O	RD+	Receiver Non-inverted DATA out. AC Coupled.	-
14	-	VeeR	Module Receiver Ground	1
15	-	VccR	Module Receiver 3.3 V Supply	-
16	-	VccT	Module Transmitter 3.3 V Supply	-
17	-	VeeT	Module Transmitter Ground	1
18	CML-I	TD+	Transmitter Non-Inverted Data Input	-
19	CML-I	TD-	Transmitter Inverted Data Input	-
20	-	VeeT	Module Transmitter Ground	1

- Notes:**
1. The module ground pins, VeeR and VeeT, shall be isolated from the module case.
  2. RX\_LOS is not available.
  3. Shall be pulled up with 4.7 K-10 Kohms to VccT in the module.

### Mechanical Dimensions

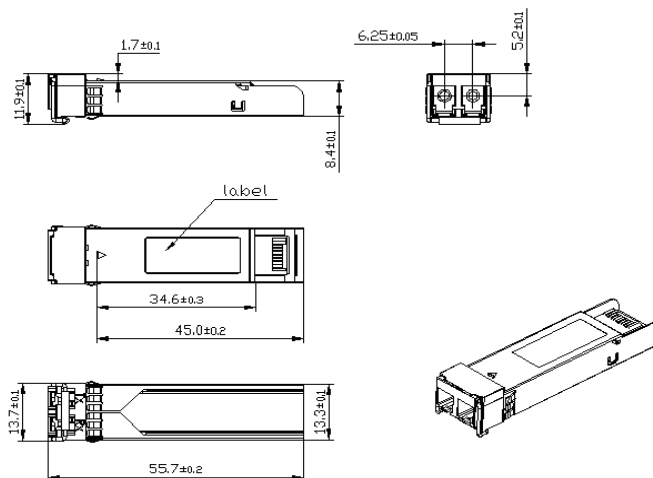



## Datasheet

### Ordering Information

Model	Description	Data Rate (Gbps)	Wavelength (nm)	Digital Diagnostics	Bail Latch Color	Max. Link Length (m)
SFP-10GD-LRM	10 Gigabit Ethernet SFP+ Transceiver, Multi-Mode	10.3125	1310	Yes	Orange	0-220

### Regulatory and Industry Compliances

Class 1 Laser Product, complies with EN 60825-1 and 21 CFR 1040.10 except for deviations pursuant to Laser Notice No. 50, dated June 24, 2007  
MSA SFF-8431; Digital Diagnostic SFF-8472; IEEE 802.3aq; Telcordia GR-468  
Certified by one or more of the following agencies: TÜV, UL, CSA  
RoHS Directive; China RoHS; California RoHS Law, REACH Directive SVHC; WEEE Directive  
The Quality Management System is certified to ISO 9001 by QMI-SAI Global  
The Environmental Management System is in compliance with ISO 14001

### Warnings

**Handling Precautions:** This device is susceptible to damage as a result of electrostatic discharge (ESD). A static free environment is highly recommended. Follow guidelines according to proper ESD procedures.

**Laser Safety:** Radiation emitted by laser devices can be dangerous to human eyes. Avoid eye exposure to direct or indirect radiation.

MRV has more than 50 offices throughout the world. Addresses, phone numbers and fax numbers are listed at [www.mrv.com](http://www.mrv.com). Please e-mail us at [info@mrv.com](mailto:info@mrv.com) or call us for assistance.

MRV Los Angeles  
20415 Nordhoff Street  
Chatsworth, CA 91311  
800-338-5316  
818-773-0900

MRV Boston  
300 Apollo Drive  
Chelmsford, MA 01824  
800-338-5316  
978-674-6800

MRV International  
Business Park Moerfelden  
Waldeckerstrasse 13  
64546 Moerfelden-Walldorf  
Germany  
Tel. (49) 6105/2070  
Fax (49) 6105/207-100

All statements, technical information and recommendations related to the products herein are based upon information believed to be reliable or accurate. However, the accuracy or completeness thereof is not guaranteed, and no responsibility is assumed for any inaccuracies. Please contact MRV Communications for more information. MRV Communications and the MRV Communications logo are trademarks of MRV Communications, Inc. Other trademarks are the property of their respective holders.