

## Datasheet

### 10 Gbps 10 km Single-Mode SFP+ Transceiver

SFP-10GD-LR



#### Highlights

- SFP+ transceiver
- Data Rates: 9.95 to 10.52 Gbps
- Protocols:
  - 10 Gbps Ethernet (LAN/WAN)
  - 10 Gbps Fibre Channel
  - SONET OC-192/STM-64
- Single-mode fiber
- Dual fiber, bi-directional
- 1310 nm
- 0 to 10 km
- Duplex LC connector
- Digital Diagnostics (SFF-8472)
- Hot-swap

#### Overview

Small Form-Factor Pluggable (SFP) interfaces from MRV Communications provide flexible high speed links in a small industry standard package. They deliver the deployment options and inventory control that network administrators demand for growing networks.

SFPs are designed to Multi-Source Agreement (MSA) standards to ensure network equipment compatibility. They are a perfect addition to MRV's extensive lines of networking equipment.

Visit the MRV website at [www.mrv.com](http://www.mrv.com) or contact your nearest authorized MRV Communications dealer for more information.

#### Specifications Overview

Data Rate	9.95 to 10.52 Gbps
Tx Wavelength	1310 nm
Tx Power (Minimum)	-8.2 dBm
Tx Dispersion Penalty	3.2 dB
Tx Disable	Yes
Rx Wavelength	1260 to 1600 nm
Rx Sensitivity @ 10.2 Gbps (OMA)	-12.6 dBm
Rx Saturation	0.5 dBm
Operating Temperature Range	-5 to 70 °C
Power Consumption	1 Watt

**Datasheet**
**Optical Specifications**

Parameter	Symbol	Minimum	Maximum	Unit	Note
<b>Transmitter</b>					
Optical Modulation Amplitude (OMA)	$P_{OMA}$	-5.2	-	dBm	-
Average Launch Power	$P_{AVE}$	-8.2	0.5	dBm	1
Optical Wavelength	$\lambda$	1260	1355	nm	-
Side-Mode Suppression Ratio	SMSR	30	-	dB	-
Optical Extinction Ratio	ER	3.5	-	dB	-
Transmitter Waveform and Dispersion Penalty	TDP	-	3.2	dB	-
Average Launch Power of OFF Transmitter	$P_{off}$	-	-30	dBm	-
Tx Jitter	$Tx_j$	Per IEEE 802.3ae requirements			-
Relative Intensity Noise	RIN	-	-128	dB/Hz	-
<b>Receiver</b>					
Receiver Sensitivity (OMA) @ 10.3 Gbps	$R_{SENS1}$	-	-12.6	dBm	2
Stressed Receiver Sensitivity (OMA) @ 10.3 Gbps	$R_{SENS2}$	-	-10.3	dBm	3
Average Receiver Power	$P_{AVE}$	-14.2	0.5	dBm	-
Optical Center Wavelength	$\lambda_C$	1260	1600	nm	-
Receiver Reflectance	$R_{rx}$	-	-12	dB	-
LOS De-Assert	$LOS_D$	-	-17	dBm	-
LOS Assert	$LOS_A$	-30	-	dBm	-
LOS Hysteresis	-	0.5	-	dB	-

- Notes:**
1. Average Power figures are informative only, per IEEE802.3ae.
  2. Valid between 1260 and 1355 nm. Measured with worst ER; BER<10<sup>-12</sup>; 2<sup>31</sup> – 1 PRBS.
  3. Valid between 1260 and 1355 nm. Per IEEE 802.3ae.

**Digital Diagnostics Specifications**

Parameter	Symbol	Min	Max	Unit	Note
<b>Accuracy</b>					
Internally Measured Transceiver Temperature	$\Delta DD_{Temperature}$	-	3	°C	-
Internally Measured Transceiver Supply Voltage	$\Delta DD_{Voltage}$	-	3	%	-
Measured TX Bias Current	$\Delta DD_{Bias}$	-	10	%	1
Measured TX Output Power	$\Delta DD_{Tx-Power}$	-	2	dB	-
Measured RX Received Average Optical Power	$\Delta DD_{Rx-Power}$	-	2	dB	-
<b>Dynamic Range for Rated Accuracy</b>					
Internally Measured Transceiver Temperature	$DD_{Temperature}$	-5	70	°C	-
Internally Measured Transceiver Supply Voltage	$DD_{Voltage}$	3.1	3.5	V	-
Measured TX Bias Current	$DD_{Bias}$	0	TBD	mA	-
Measured TX Output Power	$DD_{Tx-Power}$	-8.2	0.5	dBm	-
Measured RX Received Average Optical Power	$DD_{Rx-Power}$	-14.2	0.5	dBm	-
<b>Max Reporting Range</b>					
Internally Measured Transceiver Temperature	$DD_{Temperature}$	-40	125	°C	-
Internally Measured Transceiver Supply Voltage	$DD_{Voltage}$	2.8	4.0	V	-
Measured TX Bias Current	$DD_{Bias}$	0	20	mA	-
Measured TX Output Power	$DD_{Tx-Power}$	-10	+2	dBm	-
Measured RX Received Average Optical Power	$DD_{Rx-Power}$	-22	+2	dBm	-

- Notes:**
1. Accuracy of Measured Tx Bias Current is 10% of the actual Bias Current from the laser driver to the laser.

## Datasheet

### General Specifications

Parameter	Symbol	Minimum	Maximum	Unit	Note
Bit Rate	BR	9.95	10.52	Gbps	1
Bit Error Ratio	BER	-	$10^{-12}$	-	2
Supported Link Length	$S_{MAX}$	-	10	km	1

- Notes:**
- 10GBASE-LR, 10GBASE-LW, 10G Fibre Channel
  - Tested with a  $2^{31} - 1$  PRBS

### Absolute Maximum Ratings

Parameter	Symbol	Minimum	Maximum	Unit	Note
Maximum Supply Voltage	$V_{CC}$	-0.5	4.0	V	-
Case Operating Temperature	$T_A$	-5	70	°C	-
Storage Temperature	$T_S$	-40	85	°C	-
Relative Humidity (Non-Condensing)	RH	0	85	%	-

### Electrical Specifications

Parameter	Symbol	Minimum	Maximum	Unit	Note
Supply Voltage	$V_{CC}$	3.14	3.46	V	-
Supply Current	$I_{CC}$	-	285	mA	-
<b>Transmitter</b>					
Input Differential Impedance	$R_{in}$	80	120	$\Omega$	1
Differential Data Input Swing	$V_{in, pp}$	180	700	mV	-
Transmit Disable Voltage	$V_D$	2	$V_{CC}$	V	-
Transmit Enable Voltage	$V_{EN}$	$V_{EE}$	$V_{EE}+0.8$	V	-
<b>Receiver</b>					
Differential Data Output Swing	$V_{out, pp}$	300	850	mV	2, 6
Output Rise Time, Fall Time	$t_r, t_f$	28	-	ps	3
LOS Fault	$V_{LOS\ fault}$	2	$V_{CC\ HOST}$	V	4
LOS Normal	$V_{LOS\ norm}$	$V_{EE}$	$V_{EE}+0.8$	V	4
Power Supply Noise Tolerance	$V_{CC}T/V_{CC}R$	Per SFF-8431 Rev 2.1		mVpp	5

- Notes:**
- Connected directly to TX data input pins. AC coupling from pins into laser driver IC.
  - Into 100 $\Omega$  differential termination.
  - 20 – 80 % . Measured with Module Compliance Test Board and OMA test pattern. Use of four 1's and four 0's in sequence in the PRBS 9 is an acceptable alternative. SFF-8431 Rev 2.1
  - LOS is an open collector output. Should be pulled up with 4.7k $\Omega$  – 10k $\Omega$  on the host board. Normal operation is logic 0; loss of signal is logic 1.
  - See section 2.8.3 of SFF-8431. Rev 2.1
  - The SFP-10GD-LR is a "limiting module", i.e., it employs a limiting receiver. Host board designers using an EDC PHY IC should follow the IC manufacturer's recommended settings for interoperating the host-board EDC PHY with a limiting receiver SFP+ module.

## Datasheet

Pin Descriptions			
Pin	Function	Name/Description	Note
1	V <sub>EET</sub>	Transmitter Ground	1
2	T <sub>FAULT</sub>	Transmitter Fault	2
3	T <sub>DIS</sub>	Transmitter Disable. Laser output disabled on high or open.	3
4	SDA	2-wire Serial Interface Data Line	2
5	SCL	2-wire Serial Interface Clock Line	2
6	MOD_ABS	Module Absent. Grounded within the module.	2
7	RS0	Rate Select 0. Not Used.	4
8	RX_LOS	Loss of Signal indication. Logic 0 indicates normal operation.	5
9	RS1	Rate Select 1. Not Used.	4
10	V <sub>EER</sub>	Receiver Ground	1
11	V <sub>EER</sub>	Receiver Ground	1
12	RD-	Receiver Inverted DATA out. AC Coupled.	
13	RD+	Receiver Non-inverted DATA out. AC Coupled.	
14	V <sub>EER</sub>	Receiver Ground	1
15	V <sub>CCR</sub>	Receiver Power Supply	
16	V <sub>CCT</sub>	Transmitter Power Supply	
17	V <sub>EET</sub>	Transmitter Ground	1
18	TD+	Transmitter Non-Inverted DATA in. AC Coupled.	
19	TD-	Transmitter Inverted DATA in. AC Coupled.	
20	V <sub>EET</sub>	Transmitter Ground	1

- Notes:**
1. Circuit ground is internally isolated from chassis ground.
  2. T<sub>FAULT</sub> is an open collector/drain output, which should be pulled up with a 4.7k – 10k Ohms resistor on the host board if intended for use. Pull up voltage should be between 2.0V to V<sub>cc</sub> + 0.3V. A high output indicates a transmitter fault caused by either the TX bias current or the TX output power exceeding the preset alarm thresholds. A low output indicates normal operation. In the low state, the output is pulled to <0.8V.
  3. Laser output disabled on T<sub>DIS</sub> >2.0V or open, enabled on T<sub>DIS</sub> <0.8V.
  4. Internally pulled down per SFF-8431 Rev 2.0
  5. LOS is open collector output. Should be pulled up with 4.7kΩ – 10kΩ on host board to a voltage between 2.0V and 3.6V. Logic 0 indicates normal operation; logic 1 indicates loss of signal.

Datasheet

Diagram of Host Board Connector Block Pin Numbers and Names

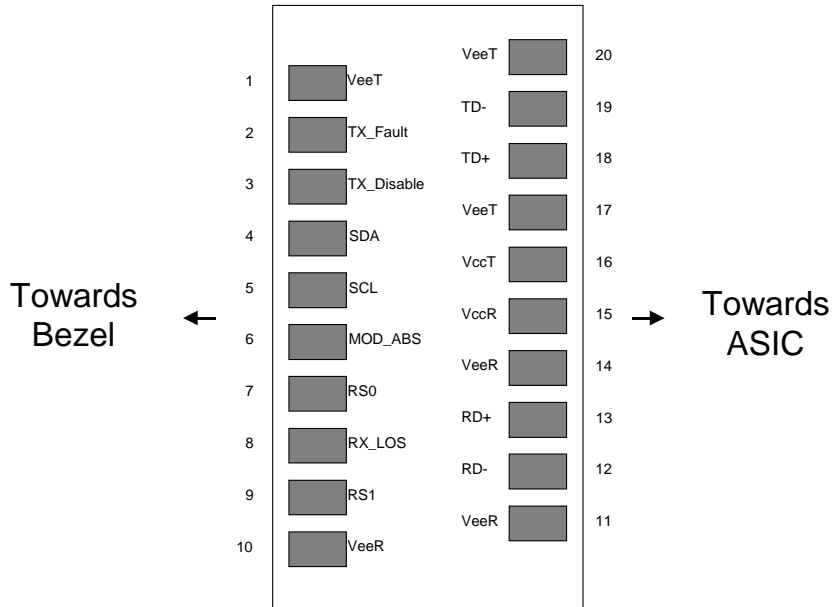

Mechanical Dimensions

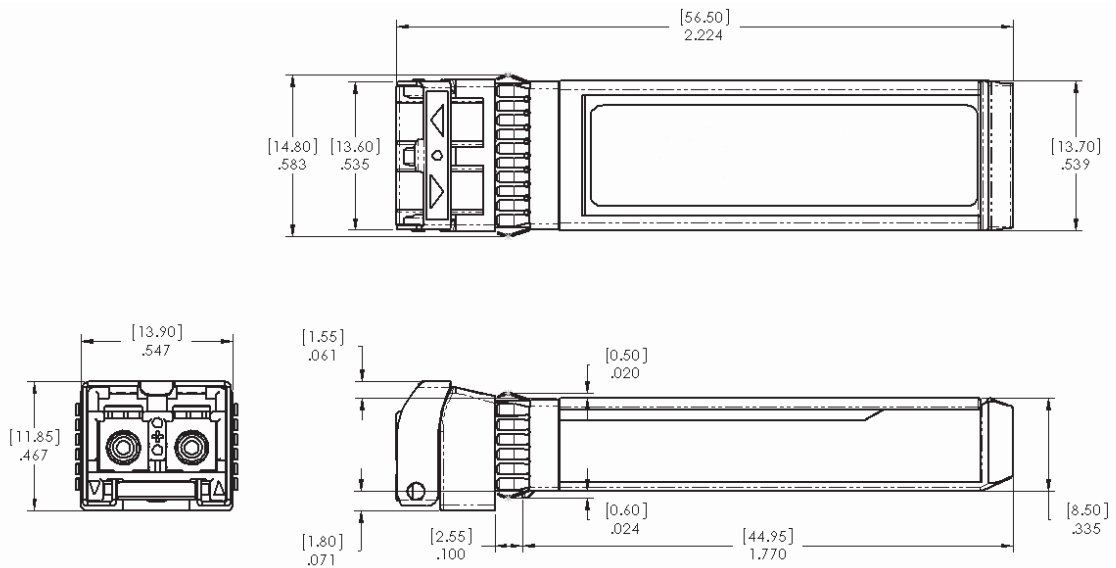



## Datasheet

### Ordering Information

Model	Description	Data Rate (Gbps)	Wavelength (nm)	Connector	Digital Diagnostics	Bail Latch Color	Max. Link Length (km)
SFP-10GD-LR	10 GE, 10 GFC, SONET OC-192/STM-64 SFP+ Transceiver, SM	9.95 - 10.52	1310	Duplex LC	Yes	Blue	0 - 10

### Regulatory and Industry Compliances

Class 1 Laser Product, complies with EN 60825-1 and 21 CFR 1040.10 except for deviations pursuant to Laser Notice No. 50. dated June 24, 2007  
MSA SFF-8074i; SFF-8431; SFF-8432; IEEE 802.3ae; Digital Diagnostic SFF-8472  
Certified by one or more of the following agencies: TÜV, UL, CSA  
RoHS Directive; China RoHS; California RoHS Law, REACH Directive SVHC; WEEE Directive  
The Quality Management System is certified to ISO 9001 by QMI-SAI Global  
The Environmental Management System is in compliance with ISO 14001

### Warnings

**Handling Precautions:** This device is susceptible to damage as a result of electrostatic discharge (ESD). A static free environment is highly recommended. Follow guidelines according to proper ESD procedures.

**Laser Safety:** Radiation emitted by laser devices can be dangerous to human eyes. Avoid eye exposure to direct or indirect radiation.

MRV has more than 50 offices throughout the world. Addresses, phone numbers and fax numbers are listed at [www.mrv.com](http://www.mrv.com).  
Please e-mail us at [info@mrv.com](mailto:info@mrv.com) or call us for assistance.

MRV Los Angeles  
20415 Nordhoff Street  
Chatsworth, CA 91311  
800-338-5316  
818-773-0900

MRV Boston  
300 Apollo Drive  
Chelmsford, MA 01824  
800-338-5316  
978-674-6800

MRV International  
Business Park Moerfelden  
Waldeckerstrasse 13  
64546 Moerfelden-Walldorf  
Germany  
Tel. (49) 6105/2070  
Fax (49) 6105/207-100

All statements, technical information, and recommendations related to the products herein are based upon information believed to be reliable or accurate. However, the accuracy or completeness thereof is not guaranteed, and no responsibility is assumed for any inaccuracies. Please contact MRV Communications for more information. MRV Communications and the MRV Communications logo are trademarks of MRV Communications, Inc. Other trademarks are the property of their respective holders.