

Datasheet

10 Gbps 850 nm Multi-mode SFP+ Transceiver

SFP-10GD-SX



Highlights

- SFP+ transceiver
- Data Rates: 9.95 to 10.52 Gbps
- Protocols:
 - 10 Gbps Ethernet (LAN/WAN)
 - 10 Gbps Fibre Channel
 - SONET OC-192/STM-64
- Multi-mode fiber (MMF)
- Dual fiber, bi-directional
- 850 nm
- Up to 300 m range on 50/125 µm (OM3) MMF
- Duplex LC connector
- Digital Diagnostics (SFF-8472)
- Hot-swap

Overview

Small Form-Factor Pluggable (SFP) interfaces from MRV Communications provide flexible high speed links in a small industry standard package. They deliver the deployment options and inventory control that network administrators demand for growing networks.

SFPs are designed to Multi-Source Agreement (MSA) standards to ensure network equipment compatibility. They are a perfect addition to MRV's extensive lines of networking equipment.

Visit the MRV website at www.mrv.com or contact your nearest authorized MRV Communications dealer for more information.

Specifications Overview

Data Rate	9.95 to 10.52 Gbps
Tx Wavelength	850 nm
Tx Power (Minimum)	-5 dBm
Tx Dispersion Penalty	3.9 dB
Tx Disable	Yes
Rx Wavelength	840 to 860 nm
Rx Sensitivity @ 10.2 Gbps (OMA)	-11.1 dBm
Rx Saturation	0.5 dBm
Operating Temperature Range	-5 to 70 °C
Power Consumption	1 Watt

Datasheet

Optical Specifications					
Parameter	Symbol	Minimum	Maximum	Unit	Note
Transmitter					
Optical Modulation Amplitude (OMA)	P_{OMA}	-	-1.5	dBm	1
Average Launch Power	P_{AVE}	-5	-1	dBm	2
Optical Wavelength	λ	840	860	nm	1
RMS Spectral Width	$\Delta\lambda_{rms}$	-	0.45	dB	1
Optical Extinction Ratio	ER	3.0	-	dB	-
Transmitter Waveform and Dispersion Penalty	TDP	-	3.9	dB	-
Average Launch Power of OFF Transmitter	P_{off}	-	-30	dBm	-
Tx Jitter	Tx	Per IEEE 802.3ae requirements		mV	-
Encircled Flux	$<4.5\mu m$ $<19\mu m$	- 86	30 -	%	3
Relative Intensity Noise	$RIN_{12,OMA}$	-	-128	dB/Hz	-
Receiver					
Receiver Sensitivity (OMA) @ 10.3 Gbps	R_{SENS1}	-	-11.1	dBm	4
Stressed Receiver Sensitivity (OMA) @ 10.3 Gbps	R_{SENS2}	-	-7.5	dBm	5
Maximum Input Power	P_{MAX}	0.5	-	dBm	-
Wavelength Range	λ_C	840	860	nm	-
Receiver Reflectance	R_{rx}	-	-12	dB	-
LOS De-Assert	LOS_D	-	-14	dBm	-
LOS Assert	LOS_A	-30	-	dBm	-
LOS Hysteresis	-	0.5	-	dB	-

- Notes:**
1. See Tradeoff Table 52.8, IEEE 802.3ae 2005
 2. Average Power figures are informative only, from IEEE802.3ae.
 3. Measured into Type A1a (50/125 μm multimode) fiber as described in ANSI/TIA/EIA-455-203-2.
 4. Measured with worst ER; BER < 10^{-12} ; $2^{31} - 1$ PRBS.
 5. See IEEE 802.3ae.

Digital Diagnostics Specifications					
Parameter	Symbol	Minimum	Maximum	Unit	Note
Accuracy					
Internally Measured Transceiver Temperature	$DD_{Temperature}$	-3	3	°C	-
Internally Measured Transceiver Supply Voltage	$DD_{Voltage}$	-100	100	mV	-
Measured TX Bias Current	DD_{Bias}	-10	10	%	1
Measured TX Output Power	$DD_{Tx-Power}$	-2	2	dB	-
Measured RX Received Average Optical Power	$DD_{Rx-Power}$	-2	2	dB	-
Dynamic Range for Rated Accuracy					
Internally Measured Transceiver Temperature	$DD_{Temperature}$	0	70	°C	-
Internally Measured Transceiver Supply Voltage	$DD_{Voltage}$	3.14	3.46	V	-
Measured TX Bias Current	DD_{Bias}	0	20	mA	-
Measured TX Output Power	$DD_{Tx-Power}$	-9	-2.5	dBm	-
Measured RX Received Average Optical Power	V_{EN}	-20	0	dBm	-
Max Reporting Range					
Internally Measured Transceiver Temperature	$DD_{Temperature}$	-40	125	°C	-
Internally Measured Transceiver Supply Voltage	$DD_{Voltage}$	2.8	4.0	V	-
Measured TX Bias Current	DD_{Bias}	0	20	mA	-
Measured TX Output Power	$DD_{Tx-Power}$	-10	-3	dBm	-
Measured RX Received Average Optical Power	$DD_{Rx-Power}$	-22	0	dBm	-

- Notes:**
1. Accuracy of Measured Tx Bias Current is 10% of the actual bias current from the laser driver to the laser.

Datasheet

General Specifications

Parameter	Symbol	Minimum	Maximum	Unit	Note
Bit Rate	BR	9.95	10.52	Gbps	1
Bit Error Ratio	BER	-	10 ⁻¹²	-	2
Maximum Supported Distances					
Fiber Type	850 nm OFL Bandwidth	-	-	-	-
62.5µm	160 MHz-km	Lmax	-	26	m
	200 MHz-km (OM1)		-	33	
50µm	160 MHz-km	Lmax	-	66	m
	200 MHz-km (OM2)		-	82	
	2000 MHz-km (OM3)		-	300	

- Notes:**
- 10GBASE-SR
 - Tested with a 2³¹ – 1 PRBS

Absolute Maximum Ratings

Parameter	Symbol	Minimum	Maximum	Unit	Note
Maximum Supply Voltage	V _{CC}	-0.5	4.0	V	-
Case Operating Temperature	T _A	0	70	°C	-
Storage Temperature	T _S	-40	85	°C	-
Relative Humidity (Non-Condensing)	RH	0	85	%	-

Electrical Specifications

Parameter	Symbol	Minimum	Maximum	Unit	Note
Supply Voltage	V _{CC}	3.14	3.46	V	-
Supply Current	I _{CC}	-	250	mA	-
Transmitter					
Input Differential Impedance	R _{in}	80	120	Ω	1
Single Ended Data Input Swing	V _{in, pp}	180	700	mV	-
Transmit Disable Voltage	V _D	2	V _{CC}	V	-
Transmit Enable Voltage	V _{EN}	V _{ee}	V _{ee} +0.8	V	-
Receiver					
Single Ended Data Output Swing	V _{out, pp}	300	850	mV	2
Data Output Rise Time, Fall Time	t _r , t _f	28	-	ps	3
LOS Fault	V _{LOS fault}	2	V _{CCHOST}	V	4
LOS Normal	V _{LOS norm}	V _{ee}	V _{ee} +0.8	V	4
Power Supply Noise Tolerance	V _{CC} T/V _{CC} R	Per SFF-8431 Rev 2.1		mVpp	5

- Notes:**
- Connected directly to TX data input pins. AC coupling from pins into laser driver IC.
 - Into 100Ω differential termination.
 - 20 – 80 % . Measured with Module Compliance Test Board and OMA test pattern. Use of four 1's and four 0's in sequence in the PRBS⁹ is an acceptable alternative. SFF-8431 Rev 2.1
 - LOS is an open collector output. Should be pulled up with 4.7kΩ – 10kΩ on the host board. Normal operation is logic 0; loss of signal is logic 1. Maximum pull-up voltage is 5.5V.
 - Testing methodology per SFF-8431. Rev 2.1

Datasheet

Pin Descriptions			
Pin	Function	Name/Description	Note
1	V _{EET}	Transmitter Ground (Common with Receiver Ground)	1
2	T _{FAULT}	Transmitter Fault	2
3	T _{DIS}	Transmitter Disable. Laser output disabled on high or open.	3
4	SDA	2-wire Serial Interface Data Line	4
5	SCL	2-wire Serial Interface Clock Line	4
6	MOD_ABS	Module Absent. Grounded within the module.	4
7	RS0	No connection required	
8	RX_LOS	Loss of Signal indication. Logic 0 indicates normal operation.	5
9	RS1	No connection required	
10	V _{EER}	Receiver Ground (Common with Transmitter Ground)	1
11	V _{EER}	Receiver Ground (Common with Transmitter Ground)	1
12	RD-	Receiver Inverted DATA out. AC Coupled.	
13	RD+	Receiver Non-inverted DATA out. AC Coupled.	
14	V _{EER}	Receiver Ground (Common with Transmitter Ground)	1
15	V _{CCR}	Receiver Power Supply	
16	V _{CCT}	Transmitter Power Supply	
17	V _{EET}	Transmitter Ground (Common with Receiver Ground)	1
18	TD+	Transmitter Non-Inverted DATA in. AC Coupled.	
19	TD-	Transmitter Inverted DATA in. AC Coupled.	
20	V _{EET}	Transmitter Ground (Common with Receiver Ground)	1

- Notes:**
1. Circuit ground is internally isolated from chassis ground.
 2. T_{FAULT} is an open collector/drain output, which should be pulled up with a 4.7k – 10k Ohms resistor on the host board if intended for use. Pull up voltage should be between 2.0V to V_{cc} + 0.3V. A high output indicates a transmitter fault caused by either the TX bias current or the TX output power exceeding the preset alarm thresholds. A low output indicates normal operation. In the low state, the output is pulled to <0.8V.
 3. Laser output disabled on TDIS >2.0V or open, enabled on TDIS <0.8V.
 4. Should be pulled up with 4.7kΩ – 10kΩ on host board to a voltage between 2.0V and 3.6V. MOD_ABS pulls line low to indicate module is plugged in.
 5. LOS is open collector output. Should be pulled up with 4.7kΩ – 10kΩ on host board to a voltage between 2.0V and 3.6V. Logic 0 indicates normal operation; logic 1 indicates loss of signal.

Datasheet

Diagram of Host Board Connector Block Pin Numbers and Names

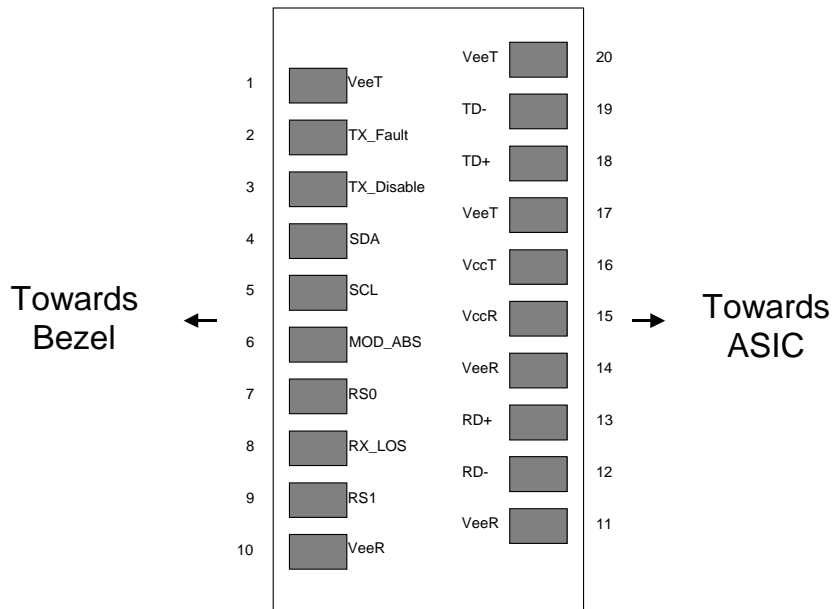

Mechanical Dimensions

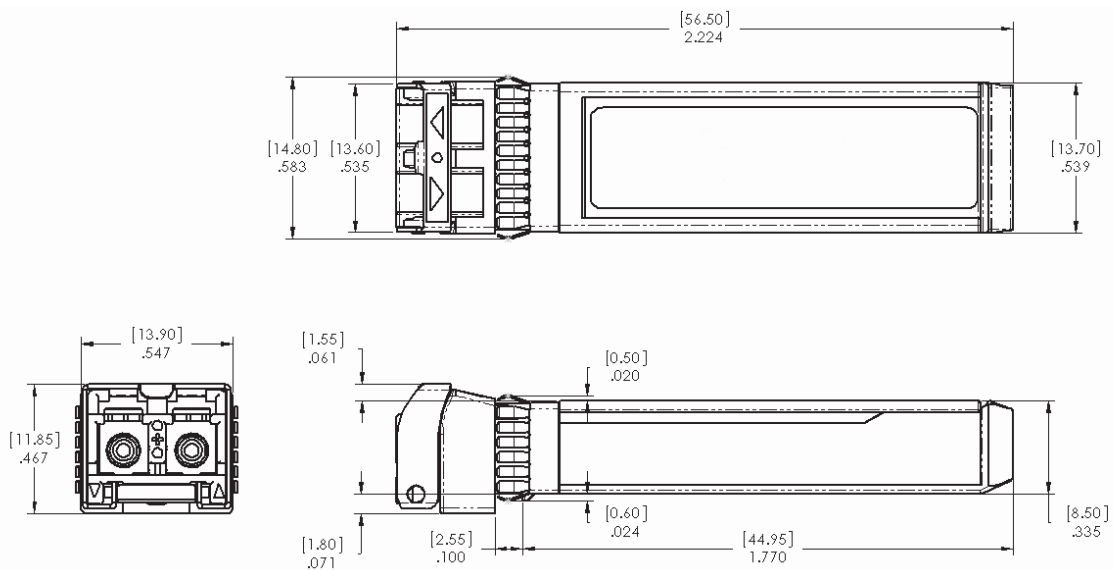



Datasheet

Ordering Information

Model	Description	Data Rate (Gbps)	Wavelength (nm)	Connector	Digital Diagnostics	Bail Latch Color	Max. Link Length (m)
SFP-10GD-SX	10 GE, 10 GFC, SONET OC-192/STM-64 SFP+ Transceiver, MM	9.95 - 10.52	850	Duplex LC	Yes	Beige	0 - 300 (50/125 µm OM3 MMF)

Regulatory and Industry Compliances

Class 1 Laser Product, complies with EN 60825-1 and 21 CFR 1040.10 except for deviations pursuant to Laser Notice No. 50. dated June 24, 2007
MSA SFF-8074i; SFF-8431; SFF-8432; IEEE 802.3ae; Digital Diagnostic SFF-8472
Certified by one or more of the following agencies: TÜV, UL, CSA
RoHS Directive; China RoHS; California RoHS Law, REACH Directive SVHC; WEEE Directive
The Quality Management System is certified to ISO 9001 by QMI-SAI Global
The Environmental Management System is in compliance with ISO 14001

Warnings

Handling Precautions: This device is susceptible to damage as a result of electrostatic discharge (ESD). A static free environment is highly recommended. Follow guidelines according to proper ESD procedures.

Laser Safety: Radiation emitted by laser devices can be dangerous to human eyes. Avoid eye exposure to direct or indirect radiation.

MRV has more than 50 offices throughout the world. Addresses, phone numbers and fax numbers are listed at www.mrv.com.
Please e-mail us at info@mrv.com or call us for assistance.

MRV Los Angeles
20415 Nordhoff Street
Chatsworth, CA 91311
800-338-5316
818-773-0900

MRV Boston
300 Apollo Drive
Chelmsford, MA 01824
800-338-5316
978-674-6800

MRV International
Business Park Moerfelden
Waldeckerstrasse 13
64546 Moerfelden-Walldorf
Germany
Tel. (49) 6105/2070
Fax (49) 6105/207-100

All statements, technical information, and recommendations related to the products herein are based upon information believed to be reliable or accurate. However, the accuracy or completeness thereof is not guaranteed, and no responsibility is assumed for any inaccuracies. Please contact MRV Communications for more information. MRV Communications and the MRV Communications logo are trademarks of MRV Communications, Inc. Other trademarks are the property of their respective holders.