

Datasheet

10 Gbps 100 GHz DWDM 80 km Single-Mode SFP+ Transceivers

SFP-10GDWZR-xx



Highlights

- SFP+ transceiver
- C-band (standard 100 GHz DWDM ITU grid)
- Data Rates: 8 Gbps to 11.3 Gbps
- Protocols supported:
 - 10G Ethernet (10GBase-ER/EW [LAN/WAN]) with/without FEC
 - 10G Fibre Channel with/without FEC
 - SONET OC-192/STM-64 with/without FEC
 - 8 Gbps Fibre Channel
- Single-mode fiber
- Dual fiber, bi-directional
- 40 - 80 km
- Duplex LC connector
- Digital Diagnostics (SFF-8472)
- Hot-swap

Overview

Small Form-Factor Pluggable (SFP) interfaces from MRV Communications provide flexible high speed links in a small industry-standard package. They deliver the deployment options and inventory control that network administrators demand for growing networks.

SFPs are designed to Multi-Source Agreement (MSA) standards to ensure network equipment compatibility. They are a perfect addition to MRV’s extensive lines of networking equipment.

Visit the MRV website at www.mrv.com or contact your nearest authorized MRV Communications dealer for more information.

Specifications Overview

Data Rate	8 - 11.3 Gbps
Tx Wavelength	100 GHz ITU Grid, C-Band DWDM (channel 17 – 61)
Tx Power (Minimum)	0 dBm
Tx Dispersion Penalty (@ 10.3125 Gbps)	< 3 dB
Tx Disable	Yes
Rx Wavelength Range	1528 - 1564 nm
Rx Sensitivity	-23 dBm
Rx Saturation	-8 dBm
Operating Temperature Range	-5 to 70 °C
Power Consumption	1 Watt

Datasheet

Transmitter Specifications (Optical)

Parameter	Symbol	Min	Max	Unit	Notes
Data Rate	B	8	11.3	Gbps	-
Center Wavelength	λ_c	See Ordering Information Table		nm	1
Average Optical Output Power	P_{avg}	0	4	dBm	-
Extinction Ratio	ER	8.2	-	dB	-
Relative Intensity Noise	RIN	-	-128	dB/Hz	-
Side Mode Suppression Ratio	SMSR	30	-	dB	-
Optical Return Loss Tolerance	-	-	-21	dB	-
Dispersion Penalty (@10.3125Gbps)	DP	-	3	dB	-
Optical Output Eye	-	Compliant with IEEE 802.3ae			-

Notes: 1. BOL: +/-0.05nm from ITU grid; EOL: +/-0.1nm from ITU grid.

Receiver Specifications (Optical)

Parameter	Symbol	Min	Max	Unit	Notes
Data Rate	B	8	11.3	Gbps	-
Wavelength of Operation	λ	1528	1565	nm	-
Receiver Sensitivity (@10.3125Gbps)	P_{min}	-	-23	dBm	1
Maximum Input Power (10^{-12} BER)	P_{max}	-8	-	dBm	-
Reflectance Of Receiver	-	-	-27	dB	-
LOS Hysteresis	-	0.5	-	dB	-
LOS Thresholds (Increasing Light Input)	P_{los+}	-	-25	dBm	-
LOS Thresholds (Decreasing Light Input)	P_{los-}	-38	-	dBm	-

Notes: 1. Specified with BER $<1 \times 10^{-12}$ and PRBS $2^{31}-1$

Absolute Maximum Ratings

Parameter	Symbol	Min	Max	Unit	Notes
Storage Temperature Range	T_{ST}	-40	85	°C	-
Operating Case Temperature	T_{OP}	-5	70	°C	1
Operating Relative Humidity	RH	0	85	%	2
Supply Voltage Range	V_{CC}	-0.5	3.6	V	-

Notes: 1. Measured on top side of SFP+ module at the front center vent hole of the cage.
2. Non condensing

Datasheet

Transmitter Specifications (Electrical)

Parameter	Symbol	Min	Max	Unit	Notes
Differential Input Impedance	Z_d	80	120	Ω	-
Differential Input Voltage Swing	$V_{PP-DIFF}$	180	700	mV	-
Input High Voltage (TX Disable)	V_{IH}	2.0	V_{CC}	V	1
Input LOW Voltage (TX Disable)	V_{IL}	0	0.8	V	1
Output High Voltage (TX Fault)	V_{OH}	2.0	$V_{CC} + 0.3$	V	2
Output LOW Voltage (TX Fault)	V_{OL}	0	0.8	V	2

- Notes:**
1. There is an internal 4.7 to 10 k Ω pull-up resistor to VccT
 2. Open collector compatible, 4.7 to 10 k Ω pull-up resistor to Vcc (Host Supply Voltage)

Receiver Specifications (Electrical)

Parameter	Symbol	Min	Max	Unit	Notes
Differential Output Impedance	Z_d	80	120	Ω	-
Differential Output Swing	$V_{PP-DIFF}$	300	850	mV	-
Output Rise and Fall time (20% to 80%)	t_{RH}, t_{FH}	28	-	ps	-
Output HIGH Voltage (LOS)	V_{OH}	$V_{CC} - 1.3$	$V_{CC} - 0.3$	V	1
Output Low Voltage (LOS)	V_{OL}	0	0.8	V	1

- Notes:**
1. Open collector compatible, 4.7 to 10 k Ω pull-up resistor to Vcc (Host Supply Voltage)

Power Supply Specifications (Electrical)

Parameter	Symbol	Min	Max	Unit	Notes
Power Supply Voltage	V_{CC}	3.13	3.47	V	-
DC Common Mode Voltage	V_{CM}	0	3.6	V	-
Supply Current	I_{VCM}	-	340	mA	-
Power Consumption	P_W	-	1.12	W	-

Host Board Connector Pinout

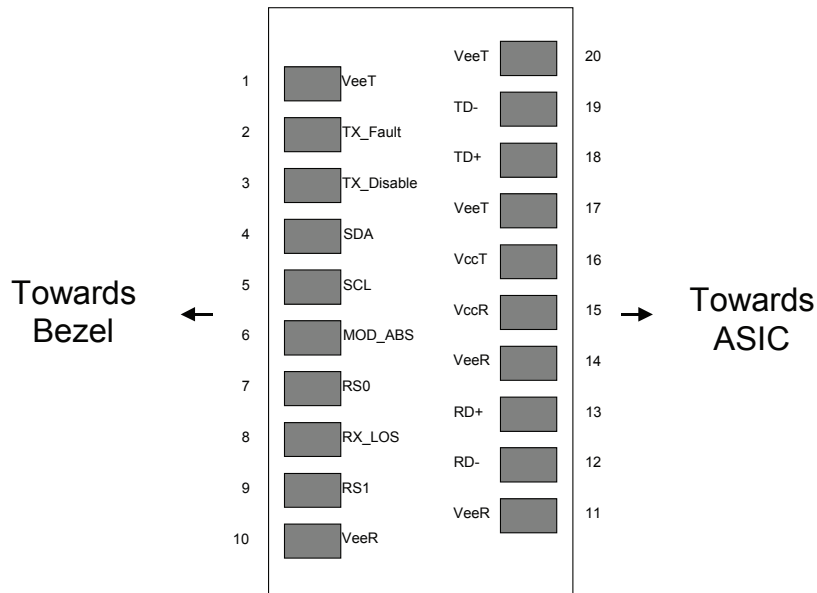

Datasheet

Pin Descriptions

Pin	Logic	Symbol	Description
1	-	VeeT	Module Transmitter Ground
2	LVTTTL-O	TX_FAULT	Module Transmitter Fault
3	LVTTTL-I	TX_DISABLE	Transmitter Disable; Turns off transmitter laser output
4	LVTTTL-I/O	SDA	2-Wire Serial Interface Data Line
5	LVTTTL-I/O	SCL	2-Wire Serial Interface Clock
6	-	MOD-ABS	Module Definition, Grounded in the module
7	LVTTTL-I	RS0	No function implemented
8	LVTTTL-O	RX_LOS	Receiver Loss of Signal Indication
9	LVTTTL-I	RS1	No function implemented
10	-	VeeR	Module Receiver Ground
11	-	VeeR	Module Receiver Ground
12	CML-O	RD-	Receiver Inverted Data Output
13	CML-O	RD+	Receiver Non-Inverted Data Output
14	-	VeeR	Module Receiver Ground
15	-	VccR	Module Receiver 3.3V Supply
16	-	VccT	Module Transmitter 3.3V Supply
17	-	VeeT	Module Transmitter Ground
18	CML-I	TD+	Transmitter Non-Inverted Data Input
19	CML-I	TD-	Transmitter Inverted Data Input
20	-	VeeT	Module Transmitter Ground

Outline Drawing

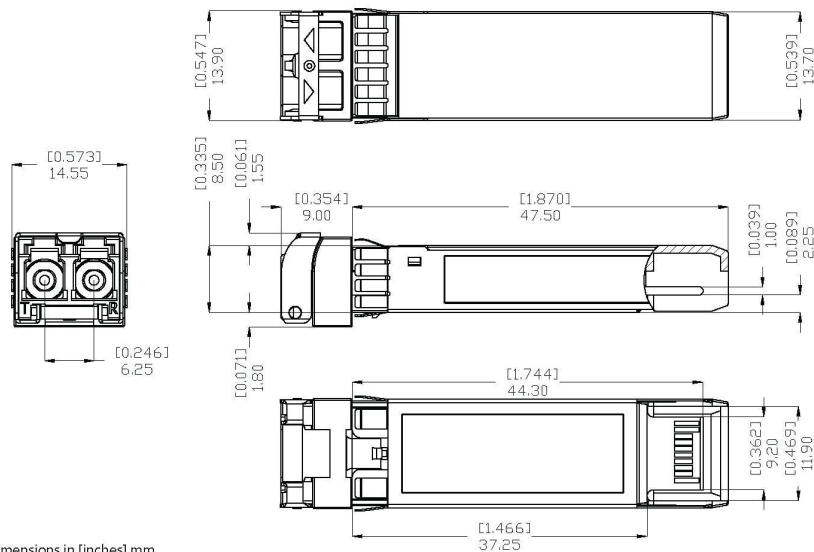

Dimensions in [inches] mm
 Millimeters are the primary units.
 Tolerances are in accordance with
 SFF-8432 Rev.5

Datasheet
Ordering Information

Model	Wavelength (nm)	Frequency (THz)	Channel Number	Distance (km)
SFP-10GDWZR-61	1528.77	196.10	61	80
SFP-10GDWZR-60	1529.55	196.00	60	80
SFP-10GDWZR-59	1530.33	195.90	59	80
SFP-10GDWZR-58	1531.12	195.80	58	80
SFP-10GDWZR-57	1531.90	195.70	57	80
SFP-10GDWZR-56	1532.68	195.60	56	80
SFP-10GDWZR-55	1533.47	195.50	55	80
SFP-10GDWZR-54	1534.25	195.40	54	80
SFP-10GDWZR-53	1535.04	195.30	53	80
SFP-10GDWZR-52	1535.82	195.20	52	80
SFP-10GDWZR-51	1536.61	195.10	51	80
SFP-10GDWZR-50	1537.40	195.00	50	80
SFP-10GDWZR-49	1538.19	194.90	49	80
SFP-10GDWZR-48	1538.98	194.80	48	80
SFP-10GDWZR-47	1539.77	194.70	47	80
SFP-10GDWZR-46	1540.56	194.60	46	80
SFP-10GDWZR-45	1541.35	194.50	45	80
SFP-10GDWZR-44	1542.14	194.40	44	80
SFP-10GDWZR-43	1542.94	194.30	43	80
SFP-10GDWZR-42	1543.73	194.20	42	80
SFP-10GDWZR-41	1544.53	194.10	41	80
SFP-10GDWZR-40	1545.32	194.00	40	80
SFP-10GDWZR-39	1546.12	193.90	39	80
SFP-10GDWZR-38	1546.92	193.80	38	80
SFP-10GDWZR-37	1547.72	193.70	37	80
SFP-10GDWZR-36	1548.52	193.60	36	80
SFP-10GDWZR-35	1549.32	193.50	35	80
SFP-10GDWZR-34	1550.12	193.40	34	80
SFP-10GDWZR-33	1550.92	193.30	33	80
SFP-10GDWZR-32	1551.72	193.20	32	80
SFP-10GDWZR-31	1552.52	193.10	31	80
SFP-10GDWZR-30	1553.33	193.00	30	80
SFP-10GDWZR-29	1554.13	192.90	29	80
SFP-10GDWZR-28	1554.94	192.80	28	80
SFP-10GDWZR-27	1555.75	192.70	27	80
SFP-10GDWZR-26	1556.56	192.60	26	80
SFP-10GDWZR-25	1557.36	192.50	25	80
SFP-10GDWZR-24	1558.17	192.40	24	80
SFP-10GDWZR-23	1558.98	192.30	23	80
SFP-10GDWZR-22	1559.79	192.20	22	80



Datasheet

Ordering Information

Model	Wavelength (nm)	Frequency (THz)	Channel Number	Distance (km)
SFP-10GDWZR-21	1560.61	192.10	21	80
SFP-10GDWZR-20	1561.42	192.00	20	80
SFP-10GDWZR-19	1562.23	191.90	19	80
SFP-10GDWZR-18	1563.05	191.80	18	80
SFP-10GDWZR-17	1563.86	191.70	17	80

Regulatory and Industry Compliances

Class 1 Laser Product, complies with EN 60825-1 and 21 CFR 1040.10 except for deviations pursuant to Laser Notice No. 50, dated June 24, 2007
MSA SFF-8074i; Digital Diagnostic SFF-8472

Certified by one or more of the following agencies: TÜV, UL, CSA

RoHS Directive; China RoHS; California RoHS Law, REACH Directive SVHC; WEEE Directive

The Quality Management System is certified to ISO 9001 by QMI-SAI Global

The Environmental Management System is in compliance with ISO 14001

Warnings

Handling Precautions: This device is susceptible to damage as a result of electrostatic discharge (ESD). A static free environment is highly recommended. Follow guidelines according to proper ESD procedures.

Laser Safety: Radiation emitted by laser devices can be dangerous to human eyes. Avoid eye exposure to direct or indirect radiation.

MRV has more than 50 offices throughout the world. Addresses, phone numbers and fax numbers are listed at www.mrv.com. Please e-mail us at info@mrv.com or call us for assistance.

MRV Los Angeles
20415 Nordhoff Street
Chatsworth, CA 91311
800-338-5316
818-773-0900

MRV Boston
300 Apollo Drive
Chelmsford, MA 01824
800-338-5316
978-674-6800

MRV International
Business Park Moerfelden
Waldeckerstrasse 13
64546 Moerfelden-Walldorf
Germany
Tel. (49) 6105/2070
Fax (49) 6105/207-100

All statements, technical information and recommendations related to the products herein are based upon information believed to be reliable or accurate. However, the accuracy or completeness thereof is not guaranteed, and no responsibility is assumed for any inaccuracies. Please contact MRV Communications for more information. MRV Communications and the MRV Communications logo are trademarks of MRV Communications, Inc. Other trademarks are the property of their respective holders.