

Datasheet

10 Gbps 50 GHz DWDM 80 km Single-Mode SFP+ Transceivers

SFP-10GDWZR-yxx



Highlights

- SFP+ transceiver
- C-band (standard 50 GHz DWDM ITU grid)
- Data Rates: 8 Gbps to 11.3 Gbps
- Protocols supported:
 - 10G Ethernet (10GBase-ER/EW [LAN/WAN]) with/without FEC
 - 10G Fibre Channel with/without FEC
 - SONET OC-192/STM-64 with/without FEC
 - 8 Gbps Fibre Channel
- Single-mode fiber
- Dual fiber, bi-directional
- 40 - 80 km
- Duplex LC connector
- Digital Diagnostics (SFF-8472)
- Hot-swap

Overview

Small Form-Factor Pluggable (SFP) interfaces from MRV Communications provide flexible high speed links in a small industry-standard package. They deliver the deployment options and inventory control that network administrators demand for growing networks.

SFPs are designed to Multi-Source Agreement (MSA) standards to ensure network equipment compatibility. They are a perfect addition to MRV's extensive lines of networking equipment.

Visit the MRV website at www.mrv.com or contact your nearest authorized MRV Communications dealer for more information.

Specifications Overview

Data Rate	8 - 11.3 Gbps
Tx Wavelength	C-Band DWDM (channel 17 – 61)
Tx Power (Minimum)	0 dBm
Tx Dispersion Penalty (@ 10.3125 Gbps)	< 3 dB
Tx Disable	Yes
Rx Wavelength Range	1528 - 1564 nm
Rx Sensitivity	-23 dBm
Rx Saturation	-8 dBm
Operating Temperature Range	-5 to 70 °C
Power Consumption	1.2 Watt

Datasheet

Transmitter Specifications (Optical)

Parameter	Symbol	Min	Max	Unit	Notes
Data Rate	B	8	11.3	Gbps	-
Center Wavelength	λ_c	See Ordering Information Table		nm	1
Average Optical Output Power	P_{avg}	0	4	dBm	-
Extinction Ratio	ER	8.2	-	dB	-
Relative Intensity Noise	RIN	-	-128	dB/Hz	-
Side Mode Suppression Ratio	SMSR	30	-	dB	-
Optical Return Loss Tolerance	-	-	-21	dB	-
Dispersion Penalty (@10.3125Gbps)	DP	-	3	dB	-
Optical Output Eye	-	Compliant with IEEE 802.3ae			-

Notes: 1. BOL: +/-0.05nm from ITU grid; EOL: +/-0.1nm from ITU grid.

Receiver Specifications (Optical)

Parameter	Symbol	Min	Max	Unit	Notes
Data Rate	B	8	11.3	Gbps	-
Wavelength of Operation	λ	1528	1565	nm	-
Receiver Sensitivity (@10.3125Gbps)	P_{min}	-	-23	dBm	1
Maximum Input Power (10^{-12} BER)	P_{max}	-8	-	dBm	-
Reflectance Of Receiver	-	-	-27	dB	-
LOS Hysteresis	-	0.5	-	dB	-
LOS Thresholds (Increasing Light Input)	P_{los+}	-	-25	dBm	-
LOS Thresholds (Decreasing Light Input)	P_{los-}	-38	-	dBm	-

Notes: 1. Specified with BER $<1 \times 10^{-12}$ and PRBS 2³¹-1

Absolute Maximum Ratings

Parameter	Symbol	Min	Max	Unit	Notes
Storage Temperature Range	T_{ST}	-40	85	°C	-
Operating Case Temperature	T_{OP}	-5	70	°C	1
Operating Relative Humidity	RH	0	85	%	2
Supply Voltage Range	V_{CC}	-0.5	3.6	V	-

Notes: 1. Measured on top side of SFP+ module at the front center vent hole of the cage.
2. Non condensing

Datasheet

Transmitter Specifications (Electrical)

Parameter	Symbol	Min	Max	Unit	Notes
Differential Input Impedance	Z_d	80	120	Ω	-
Differential Input Voltage Swing	$V_{PP-DIFF}$	180	700	mV	-
Input High Voltage (TX Disable)	V_{IH}	2.0	V_{CC}	V	1
Input LOW Voltage (TX Disable)	V_{IL}	0	0.8	V	1
Output High Voltage (TX Fault)	V_{OH}	2.0	$V_{CC} + 0.3$	V	2
Output LOW Voltage (TX Fault)	V_{OL}	0	0.8	V	2

- Notes:**
1. There is an internal 4.7 to 10 k Ω pull-up resistor to VccT
 2. Open collector compatible, 4.7 to 10 k Ω pull-up resistor to Vcc (Host Supply Voltage)

Receiver Specifications (Electrical)

Parameter	Symbol	Min	Max	Unit	Notes
Differential Output Impedance	Z_d	80	120	Ω	-
Differential Output Swing	$V_{PP-DIFF}$	300	850	mV	-
Output Rise and Fall time (20% to 80%)	t_{RH}, t_{FH}	28	-	ps	-
Output HIGH Voltage (LOS)	V_{OH}	$V_{CC} - 1.3$	$V_{CC} - 0.3$	V	1
Output Low Voltage (LOS)	V_{OL}	0	0.8	V	1

- Notes:**
1. Open collector compatible, 4.7 to 10 k Ω pull-up resistor to Vcc (Host Supply Voltage)

Power Supply Specifications (Electrical)

Parameter	Symbol	Min	Max	Unit	Notes
Power Supply Voltage	V_{CC}	3.13	3.47	V	-
DC Common Mode Voltage	V_{CM}	0	3.6	V	-
Supply Current	I_{VCM}	-	340	mA	-
Power Consumption	P_W	-	1.2	W	-

Host Board Connector Pinout

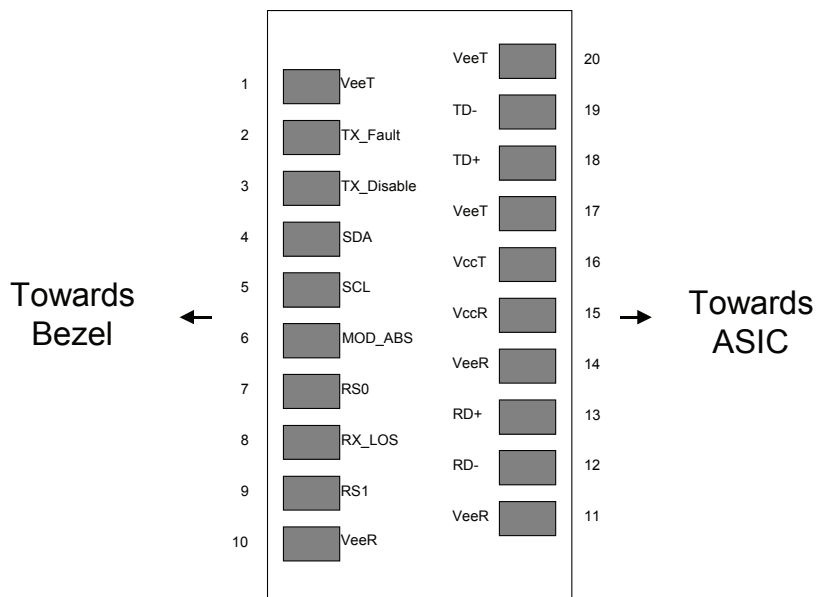

Datasheet

Pin Descriptions

Pin	Logic	Symbol	Description
1	-	VeeT	Module Transmitter Ground
2	LVTTL-O	TX_FAULT	Module Transmitter Fault
3	LVTTL-I	TX_DISABLE	Transmitter Disable; Turns off transmitter laser output
4	LVTTL-I/O	SDA	2-Wire Serial Interface Data Line
5	LVTTL-I/O	SCL	2-Wire Serial Interface Clock
6	-	MOD-ABS	Module Definition, Grounded in the module
7	LVTTL-I	RS0	No function implemented
8	LVTTL-O	RX_LOS	Receiver Loss of Signal Indication
9	LVTTL-I	RS1	No function implemented
10	-	VeeR	Module Receiver Ground
11	-	VeeR	Module Receiver Ground
12	CML-O	RD-	Receiver Inverted Data Output
13	CML-O	RD+	Receiver Non-Inverted Data Output
14	-	VeeR	Module Receiver Ground
15	-	VccR	Module Receiver 3.3V Supply
16	-	VccT	Module Transmitter 3.3V Supply
17	-	VeeT	Module Transmitter Ground
18	CML-I	TD+	Transmitter Non-Inverted Data Input
19	CML-I	TD-	Transmitter Inverted Data Input
20	-	VeeT	Module Transmitter Ground

Outline Drawing

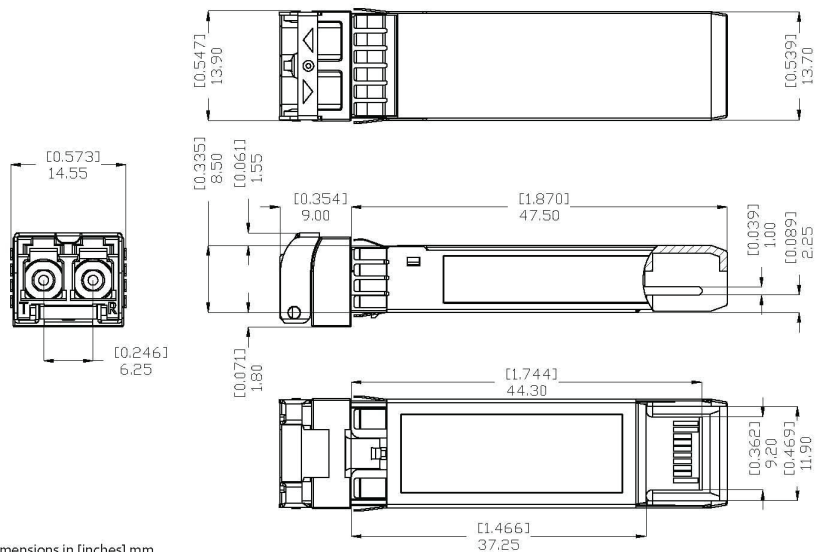

Dimensions in [inches] mm
 Millimeters are the primary units.
 Tolerances are in accordance with
 SFF-8432 Rev.5

Datasheet

Ordering Information

Model	Wavelength (nm)	Frequency (THz)	Channel Number	Distance (km)
SFP-10GDWZR-H61	1528.38	196.15	H61	80
SFP-10GDWZR-C61	1528.77	196.10	C61	80
SFP-10GDWZR-H60	1529.16	196.05	H60	80
SFP-10GDWZR-C60	1529.55	196.00	C60	80
SFP-10GDWZR-H59	1529.94	195.95	H59	80
SFP-10GDWZR-C59	1530.33	195.90	C59	80
SFP-10GDWZR-H58	1530.73	195.85	H58	80
SFP-10GDWZR-C58	1531.12	195.80	C58	80
SFP-10GDWZR-H57	1531.51	195.75	H57	80
SFP-10GDWZR-C57	1531.90	195.70	C57	80
SFP-10GDWZR-H56	1532.29	195.65	H56	80
SFP-10GDWZR-C56	1532.68	195.60	C56	80
SFP-10GDWZR-H55	1533.07	195.55	H55	80
SFP-10GDWZR-C55	1533.47	195.50	C55	80
SFP-10GDWZR-H54	1533.86	195.45	H54	80
SFP-10GDWZR-C54	1534.25	195.40	C54	80
SFP-10GDWZR-H53	1534.64	195.35	H53	80
SFP-10GDWZR-C53	1535.04	195.30	C53	80
SFP-10GDWZR-H52	1535.43	195.25	H52	80
SFP-10GDWZR-C52	1535.82	195.20	C52	80
SFP-10GDWZR-H51	1536.22	195.15	H51	80
SFP-10GDWZR-C51	1536.61	195.10	C51	80
SFP-10GDWZR-H50	1537.00	195.05	H50	80
SFP-10GDWZR-C50	1537.40	195.00	C50	80
SFP-10GDWZR-H49	1537.79	194.95	H49	80
SFP-10GDWZR-C49	1538.19	194.90	C49	80
SFP-10GDWZR-H48	1538.58	194.85	H48	80
SFP-10GDWZR-C48	1538.98	194.80	C48	80
SFP-10GDWZR-H47	1539.37	194.75	H47	80
SFP-10GDWZR-C47	1539.77	194.70	C47	80
SFP-10GDWZR-H46	1540.16	194.65	H46	80
SFP-10GDWZR-C46	1540.56	194.60	C46	80
SFP-10GDWZR-H45	1540.95	194.55	H45	80
SFP-10GDWZR-C45	1541.35	194.50	C45	80
SFP-10GDWZR-H44	1541.75	194.45	H44	80
SFP-10GDWZR-C44	1542.14	194.40	C44	80
SFP-10GDWZR-H43	1542.54	194.35	H43	80
SFP-10GDWZR-C43	1542.94	194.30	C43	80
SFP-10GDWZR-H42	1543.33	194.25	H42	80
SFP-10GDWZR-C42	1543.73	194.20	C42	80

Datasheet

Ordering Information

Model	Wavelength (nm)	Frequency (THz)	Channel Number	Distance (km)
SFP-10GDWZR-H41	1544.13	194.15	H41	80
SFP-10GDWZR-C41	1544.53	194.10	C41	80
SFP-10GDWZR-H40	1544.92	194.05	H40	80
SFP-10GDWZR-C40	1545.32	194.00	C40	80
SFP-10GDWZR-H39	1545.72	193.95	H39	80
SFP-10GDWZR-C39	1546.12	193.90	C39	80
SFP-10GDWZR-H38	1546.52	193.85	H38	80
SFP-10GDWZR-C38	1546.92	193.80	C38	80
SFP-10GDWZR-H37	1547.32	193.75	H37	80
SFP-10GDWZR-C37	1547.72	193.70	C37	80
SFP-10GDWZR-H36	1548.12	193.65	H36	80
SFP-10GDWZR-C36	1548.52	193.60	C36	80
SFP-10GDWZR-H35	1548.92	193.55	H35	80
SFP-10GDWZR-C35	1549.32	193.50	C35	80
SFP-10GDWZR-H34	1549.72	193.45	H34	80
SFP-10GDWZR-C34	1550.12	193.40	C34	80
SFP-10GDWZR-H33	1550.52	193.35	H33	80
SFP-10GDWZR-C33	1550.92	193.30	C33	80
SFP-10GDWZR-H32	1551.32	193.25	H32	80
SFP-10GDWZR-C32	1551.72	193.20	C32	80
SFP-10GDWZR-H31	1552.12	193.15	H31	80
SFP-10GDWZR-C31	1552.52	193.10	C31	80
SFP-10GDWZR-H30	1552.93	193.05	H30	80
SFP-10GDWZR-C30	1553.33	193.00	C30	80
SFP-10GDWZR-H29	1553.73	192.95	H29	80
SFP-10GDWZR-C29	1554.13	192.90	C29	80
SFP-10GDWZR-H28	1554.54	192.85	H28	80
SFP-10GDWZR-C28	1554.94	192.80	C28	80
SFP-10GDWZR-H27	1555.34	192.75	H27	80
SFP-10GDWZR-C27	1555.75	192.70	C27	80
SFP-10GDWZR-H26	1556.15	192.65	H26	80
SFP-10GDWZR-C26	1556.56	192.60	C26	80
SFP-10GDWZR-H25	1556.96	192.55	H25	80
SFP-10GDWZR-C25	1557.36	192.50	C25	80
SFP-10GDWZR-H24	1557.77	192.45	H24	80
SFP-10GDWZR-C24	1558.17	192.40	C24	80
SFP-10GDWZR-H23	1558.58	192.35	H23	80
SFP-10GDWZR-C23	1558.98	192.30	C23	80
SFP-10GDWZR-H22	1559.39	192.25	H22	80
SFP-10GDWZR-C22	1559.79	192.20	C22	80

Datasheet

Ordering Information

Model	Wavelength (nm)	Frequency (THz)	Channel Number	Distance (km)
SFP-10GDWZR-H21	1560.20	192.15	H21	80
SFP-10GDWZR-C21	1560.61	192.10	C21	80
SFP-10GDWZR-H20	1561.01	192.05	H20	80
SFP-10GDWZR-C20	1561.42	192.00	C20	80
SFP-10GDWZR-H19	1561.83	191.95	H19	80
SFP-10GDWZR-C19	1562.23	191.90	C19	80
SFP-10GDWZR-H18	1562.64	191.85	H18	80
SFP-10GDWZR-C18	1563.05	191.80	C18	80
SFP-10GDWZR-H17	1563.46	191.75	H17	80
SFP-10GDWZR-C17	1563.86	191.70	C17	80

Regulatory and Industry Compliances

Class 1 Laser Product, complies with EN 60825-1 and 21 CFR 1040.10 except for deviations pursuant to Laser Notice No. 50. dated June 24, 2007
MSA SFF-8074i; Digital Diagnostic SFF-8472

Certified by one or more of the following agencies: TÜV, UL, CSA

RoHS Directive; China RoHS; California RoHS Law, REACH Directive SVHC; WEEE Directive

The Quality Management System is certified to ISO 9001 by QMI-SAI Global

The Environmental Management System is in compliance with ISO 14001

Warnings

Handling Precautions: This device is susceptible to damage as a result of electrostatic discharge (ESD). A static free environment is highly recommended. Follow guidelines according to proper ESD procedures.

Laser Safety: Radiation emitted by laser devices can be dangerous to human eyes. Avoid eye exposure to direct or indirect radiation.

MRV has more than 50 offices throughout the world. Addresses, phone numbers and fax numbers are listed at www.mrv.com.
Please e-mail us at info@mrv.com or call us for assistance.

MRV Los Angeles
20415 Nordhoff Street
Chatsworth, CA 91311
800-338-5316
818-773-0900

MRV Boston
300 Apollo Drive
Chelmsford, MA 01824
800-338-5316
978-952-4700

MRV International
Business Park Moerfelden
Waldeckerstrasse 13
64546 Moerfelden-Walldorf
Germany
Tel. (49) 6105/2070
Fax (49) 6105/207-100

All statements, technical information, and recommendations related to the products herein are based upon information believed to be reliable or accurate. However, the accuracy or completeness thereof is not guaranteed, and no responsibility is assumed for any inaccuracies. Please contact MRV Communications for more information. MRV Communications and the MRV Communications logo are trademarks of MRV Communications, Inc. Other trademarks are the property of their respective holders.