

**Datasheet**

**Multi-Rate (2 Gbps) CWDM 96 km SFP Transceivers**

SFP-27DCWLR-xx



**Highlights**

- SFP transceiver
- Data Rates: 0.1 - 2.7 Gbps
- Protocols:
  - Fast Ethernet
  - Gigabit Ethernet
  - Fibre Channel (1 and 2 Gbps)
  - OC-3/STM-1 to OC-48/STM-16
  - OC-48/STM-16 with FEC
  - ESCON
- Single-mode fiber
- Dual fiber, bi-directional
- CWDM wavelength per ITU-T G.694.2
- 40 to 96 km range
- Duplex LC connector
- Digital Diagnostics (SFF-8472)
- Hot-swap
- Industrial temperature models available

**Overview**

Small Form-Factor Pluggable (SFP) interfaces from MRV Communications provide flexible high speed links in a small industry-standard package. They deliver the deployment options and inventory control that network administrators demand for growing networks.

SFPs are designed to Multi-Source Agreement (MSA) standards to ensure network equipment compatibility. They are a perfect addition to MRV’s extensive lines of networking equipment.

Visit the MRV website at [www.mrv.com](http://www.mrv.com) or contact your nearest authorized MRV Communications dealer for more information.

**Specifications Overview**

Data Rate	0.1 - 2.7 Gbps
Tx Wavelength	CWDM grid (1271 nm - 1611 nm)
Tx Power (Minimum)	-2 dBm
Dispersion Penalty	2 dB
Tx Disable Option	Yes
Rx Wavelength Range	1200 - 1625 nm
Rx Sensitivity	-28 dBm
Rx Saturation	-6 dBm
Rx Damage Threshold	4 dBm
Operating Temperature Range	-5 to 70 °C
Operating Temperature Range (TH Models)	-40 to 85 °C
Power Consumption	1 Watt

## Datasheet

### Transmitter Specifications (Optical)

Parameter	Symbol	Min	Max	Unit	Notes
Optical Power	P <sub>op</sub>	-2	3	dBm	-
Average Launch Power Tx_Off	P <sub>off</sub>	-	-45	dBm	-
Extinction Ratio	ER	8.2	-	dB	-
Eye Mask	IEEE 802.3ah, SONET/SDH compliant				-
Optical Jitter Generation	J <sub>gen</sub>	-	0.007	UI	-
Optical Rise/Fall Time	t <sub>r</sub>	-	160	ps	1
Mean Wavelength	λ	1xxx - 6.5 nm	1xx1 + 6.5 nm	nm	-
Spectral Width (20 dB)	Δλ	-	1	nm	-
Dispersion Penalty at 80 km	dp	-	2	dB	2
Relative Intensity Noise	RIN	-	-120	dB/Hz	-
Reflection Tolerance	rp	-24	-	dB	3

- Notes:**
1. 20%~80% values
  2. Measured at BER of 1E<sup>-12</sup>, PRBS of 2<sup>23</sup>-1, at eye center
  3. 1 dB degradation of receiver sensitivity

### Receiver Specifications (Optical)

Parameter	Symbol	Min	Max	Unit	Notes
Receive Power Low	R <sub>sens,low</sub>	-	-28	dBm	1
Receive Power High	R <sub>sens,high</sub>	-6	-	dBm	1
Damage Threshold For Receiver	P <sub>in,damage</sub>	4	-	dBm	-
Wavelength	λ	1200	1625	nm	-
Maximum Reflectance Of Receiver	RX <sub>r</sub>	-	-27	dB	-
LOS Assert	-	-42	-	dBm	-
LOS De-assert	-	-	-28	dBm	-
LOS Hysteresis	-	0.5	-	dB	-

- Notes:**
1. 10<sup>-10</sup> BER, PRBS 2<sup>23</sup>-1, for SONET, 10<sup>-12</sup> BER, PRBS 2<sup>7</sup>-1, for Gigabit Ethernet

### Digital Diagnostics

Parameter	Range	Accuracy	Unit	Calibration	Formula
Temperature	-5 to 70	± 3	°C	External	Tc(C)=Tslope* <i>T</i> ad (16 bit signed twos complement value) + Toffset
Temperature (TH Models)	-40 to 85	± 3	°C	External	Tc(C)=Tslope* <i>T</i> ad (16 bit signed twos complement value) + Toffset
Voltage	0 to V <sub>CC</sub>	0.1	V	External	V(Volts)=Vslope* <i>V</i> ad (16 bit unsigned integer) + Voffset
Bias Current	0 to 120	5	mA	External	I(mA)=Islope* <i>I</i> ad(16 bit unsigned integer)+Ioffset
TX Power	-2 to 3	±3 dB	dBm	External	TX_PWR(μW)=TX_PWRslope*TX_PWRad (16 bit unsigned integer) +TX_PWRoffset
RX Power	-28 to -6	±3 dB	dBm	External	RX_PWR(μW)=A0+A1*x+A2*x^2+A3*x^3+A4*x^4

## Datasheet

### General Operating Conditions

Parameter	Symbol	Min	Max	Unit	Notes
Supply Voltage	$V_{CC}$	3.135	3.465	V	-
Total Current, -40 to -5 °C	$I_{CC}$	-	500	mA	1
Total Current, -5 to 85 °C	$I_{CC}$	-	300	mA	-
Total Current Each Supply Pin	$I_{CCR}, I_{CCT}$	-	300	mA	-
Power Supply Noise Rejection	PSR	100	-	mV <sub>p-p</sub>	2
Operating Case Temperature	$T_{opr}$	-5	70	°C	3
Operating Case Temperature (TH Models)	$T_{opr}$	-40	85	°C	3
Storage Temperature	$T_{stg}$	-40	85	°C	-
Data Rate	DR	0.1	2.7	Gbps	-

- Notes:**
1. Denotes deviation from MSA
  2. 20Hz to 155MHz
  3. Please refer to ordering information

### Transmitter Specifications (Electical)

Parameter	Symbol	Min	Max	Unit	Notes
Input Differential Impedence	$R_{in}$	80	120	$\Omega$	-
PECL Single Ended Data Input Swing	$V_{in,p-p}$	250	1200	mV	-
TxFault_Fault	$V_{fault}$	2	$V_{CC}$	V	-
TxFault_Normal	$V_{normal}$	$V_{EE}$	$V_{EE}+0.5$	V	-
TxDisable_Disable	$V_d$	2	$V_{CC}$	V	-
TxDisable_Enable	$V_{en}$	$V_{EE}$	$V_{EE}+0.8$	V	-

### Receiver Specifications (Electrical)

Parameter	Symbol	Min	Max	Unit	Notes
PECL Single Ended Data Output Swing	$V_{out,p-p}$	185	800	mV	-
Data Output Rise/Fall Time	$t_r, t_f$	-	175	ps	-

### Timing and Electrical

Parameter	Symbol	Min	Max	Unit	Notes
Tx Disable Negate Time	$t_{on}$	-	1	ms	-
Tx Disable Assert Time	$t_{off}$	-	10	$\mu$ s	-
Time To Initialize, Including Reset Of Tx Fault	$t_{init}$	-	300	ms	-
Tx Fault Assert Time	$t_{fault}$	-	100	$\mu$ s	-
Tx Disable To Reset	$t_{reset}$	10	-	$\mu$ s	-
LOS Assert Time	$t_{loss_{on}}$	-	100	$\mu$ s	-
LOS De-assert Time	$t_{loss_{off}}$	-	100	$\mu$ s	-
Serial ID Clock Rate	$f_{serial\_clock}$	-	100	KHz	-
RX_LOS Voltage (High)	$RX\_LOS_H$	2	-	V	-
RX_LOS Voltage (Low)	$RX\_LOS_L$	-	0.8	V	-
MOD_DEF (0:2)-High	$V_H$	2	$V_{CC}$	V	-
MOD_DEF (0:2)-Low	$V_L$	$V_{EE}$	$V_{EE}+0.5$	V	-
LOS Output Voltage-Fault	$V_{LOS\ fault}$	2	$V_{CC}$	V	-
LOS Output Voltage-Normal	$V_{LOS\ normal}$	$V_{EE}$	$V_{EE}+0.5$	V	-

## Datasheet

Pin	Function	Notes
1	V <sub>ee</sub> T	TX GND
2	TX_FAULT	Open Collector
3	TX_DISABLE	Internally Pulled High
4	MOD_DEF2	Serial Data Input
5	MOD_DEF1	Serial Clock Input
6	MOD_DEF0	Internally Grounded
7	NC	Not Connected
8	LOS	Open Collector
9	V <sub>ee</sub> R	RX Ground
10	V <sub>ee</sub> R	RX Ground
11	V <sub>ee</sub> R	RX Ground
12	RXD-	RX Data Negative
13	RXD+	RX Data Positive
14	V <sub>ee</sub> R	RX GND
15	V <sub>cc</sub> R	RX Power
16	V <sub>cc</sub> T	TX Power
17	V <sub>ee</sub> T	TX GND
18	TXD+	TX Data Positive
19	TXD-	TX Data Negative
20	V <sub>ee</sub> T	TX GND

## Outline Drawing

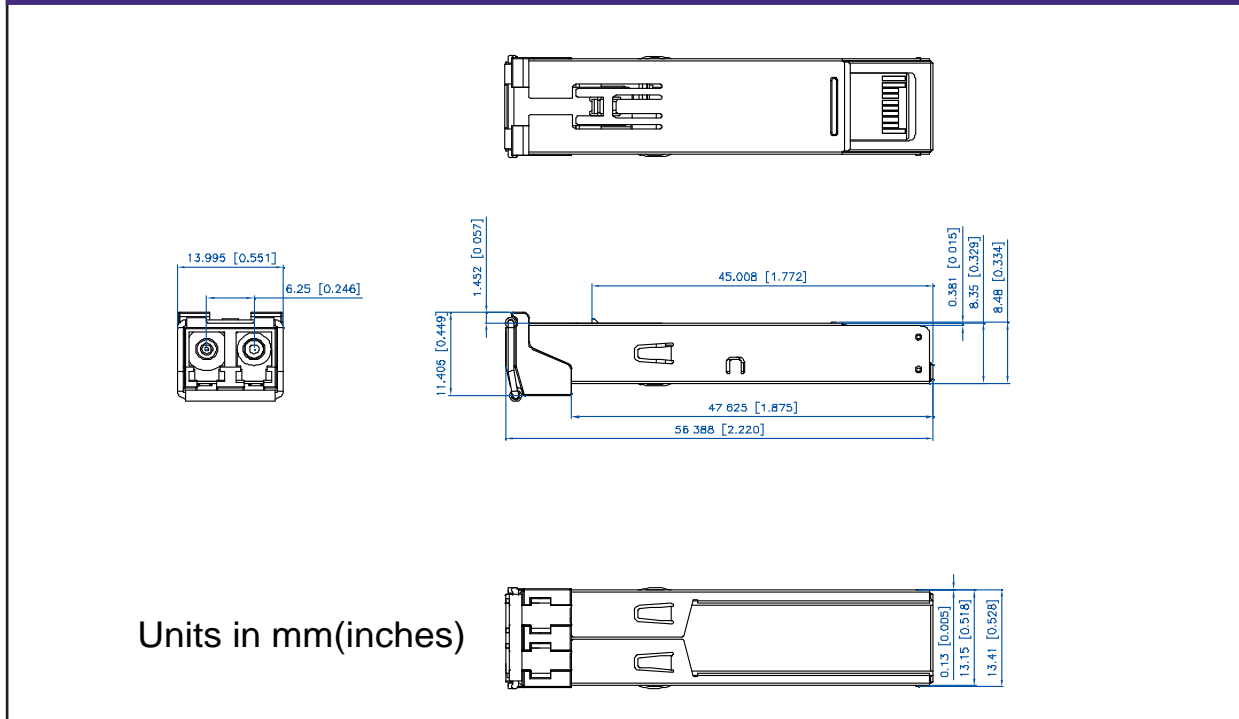



## Datasheet

### Ordering Information

Model	Description	Data Rate (Gbps)	Wavelength (nm)	Distance Range (km)
SFP-27DCWLR-xx *	Multi-Rate CWDM SFP Transceiver	0.1 - 2.7	xx (see Wavelength Guide below)	40 - 96
SFP27DCWLRTH-xx *	Multi-Rate CWDM SFP Transceiver, <i>Temperature Hardened</i>	0.1 - 2.7	xx (see Wavelength Guide below)	40 - 96

\*See Wavelength Guide below for "xx" values

### λc Wavelength Guide per ITU-T G.694.2

Code	λc	Unit	Bail Latch Color	Code	λc	Unit	Bail Latch Color
27	1271	nm	Yellow	45	1451	nm	Yellow
29	1291	nm	Yellow	47	1471	nm	Grey
31	1311	nm	Yellow	49	1491	nm	Purple
33	1331	nm	Yellow	51	1511	nm	Blue
35	1351	nm	Yellow	53	1531	nm	Green
37	1371	nm	Yellow	55	1551	nm	Yellow
39	1391	nm	Yellow	57	1571	nm	Orange
41	1411	nm	Yellow	59	1591	nm	Red
43	1431	nm	Yellow	61	1611	nm	Brown

### Regulatory and Industry Compliances

Class 1 Laser Product, complies with EN 60825-1 and 21 CFR 1040.10 except for deviations pursuant to Laser Notice No. 50, dated June 24, 2007  
MSA SFF-8074i; Digital Diagnostic SFF-8472

Certified by one or more of the following agencies: TÜV, UL, CSA

RoHS Directive; China RoHS; California RoHS Law, REACH Directive SVHC; WEEE Directive

The Quality Management System is certified to ISO 9001 by QMI-SAI Global

The Environmental Management System is in compliance with ISO 14001

### Warnings

**Handling Precautions:** This device is susceptible to damage as a result of electrostatic discharge (ESD). A static free environment is highly recommended. Follow guidelines according to proper ESD procedures.

**Laser Safety:** Radiation emitted by laser devices can be dangerous to human eyes. Avoid eye exposure to direct or indirect radiation.

MRV has more than 50 offices throughout the world. Addresses, phone numbers and fax numbers are listed at [www.mrv.com](http://www.mrv.com). Please e-mail us at [info@mrv.com](mailto:info@mrv.com) or call us for assistance.

MRV Los Angeles  
20415 Nordhoff Street  
Chatsworth, CA 91311  
800-338-5316  
818-773-0900

MRV Boston  
300 Apollo Drive  
Chelmsford, MA 01824  
800-338-5316  
978-674-6800

MRV International  
Business Park Moerfelden  
Waldeckerstrasse 13  
64546 Moerfelden-Walldorf  
Germany  
Tel. (49) 6105/2070  
Fax (49) 6105/207-100

All statements, technical information and recommendations related to the products herein are based upon information believed to be reliable or accurate. However, the accuracy or completeness thereof is not guaranteed, and no responsibility is assumed for any inaccuracies. Please contact MRV Communications for more information. MRV Communications and the MRV Communications logo are trademarks of MRV Communications, Inc. Other trademarks are the property of their respective holders.