

Datasheet

2.7 Gbps Multi-Rate 120 km DWDM SFP Transceivers

SFP27DWLR12-xx



Features

- SFP transceiver
- C-band (standard 100 GHz DWDM ITU grid)*
- Data Rates: 100 Mbps to 2.7 Gbps
- Protocols:
 - Fast Ethernet
 - Gigabit Ethernet
 - 1 Gbps Fibre Channel
 - 2 Gbps Fibre Channel
 - Digital Video
 - OC-3/STM-1 to OC-48/STM-16 and OC-48 with FEC
- Single-mode fiber
- 1-channel DWDM Tx
- Full-band Rx
- 40 - 120 km
- Duplex LC connector
- Digital Diagnostics (SFF-8472)
- Hot-swap

* L-band channels are available by request

Overview

Small Form-Factor Pluggable (SFP) interfaces from MRV Communications provide flexible high speed links in a small industry standard package. They deliver the deployment options and inventory control that network administrators demand for growing networks.

SFPs are designed to Multi-Source Agreement (MSA) standards to ensure network equipment compatibility. They are a perfect addition to MRV's extensive lines of networking equipment.

Visit the MRV website at www.mrv.com or contact your nearest authorized MRV Communications dealer for more information.

Specifications Overview

Data Rate	100 - 2700 Mbps
Tx Wavelength	1-channel C-Band DWDM Tx (channel 17 – 61)
Tx Power (Minimum)	0 dBm
Tx Dispersion Penalty	< 2 dB
Tx Dispersion Tolerance	2400 ps/nm
Tx Disable	Yes
Rx Wavelength Range	1528 - 1564 nm
Rx Sensitivity	-28 dBm
Rx Saturation	-6 dBm
Damage Threshold	4 dBm
Operating Temperature Range	-5 to 70 °C
Power Consumption	1 Watt

Datasheet

Optical Transmitter Specifications

Parameter	Symbol	Min	Max	Unit	Notes
Optical Power	P_{OP}	0	4	dBm	-
Average Launch Power (Tx: Off)	P_{Off}	-	-30	dBm	-
Extinction Ratio	ER	8.2	-	dB	-
Eye Mask	IEEE 802.3z, SONET/SDH compliant				-
Optical Jitter Generation	Jgen(pk-pk)	-	0.07	UI	-
Optical Rise Time	t_r	-	160	ps	1
Optical Fall Time	t_f	-	160	ps	1
Channel Spacing	Δf	100		GHz	-
Deviation From Central Frequency, EOL	-	-	± 12	GHz	-
Spectral Width (20 dB)	$\Delta \lambda$	-	0.3	nm	-
Side Mode Suppression Ratio	SMSR	30	-	dB	-
Dispersion Penalty at specified distance	dp	-	<2	dB	2
Relative Intensity Noise	RIN	-	-135	dB/Hz	-
Reflection Tolerance	rp	-24	-	dB	3

- Notes:**
- 20%-80% values
 - Measured at BER of 10^{-12} , PRBS of $2^{23}-1$, at eye center, OC-48.
 - 2 dB degradation of receiver sensitivity

Optical Receiver Specifications

Parameter	Symbol	Min	Max	Unit	Notes
Receive Power	$R_{sens,low/high}$	-28	-6	dBm	1
Receive Power at Specified Distance and 20 dB OSNR	$R_{sens,OSNR}$	-	-24	dBm	1
Damage Threshold for Receiver	$P_{in,damage}$	4	-	dBm	-
Wavelength	λ	1528	1564	nm	-
Maximum Reflectance of Receiver	RX_r	-	-27	dB	-
LOS Assert	-	-40	-	dBm	-
LOS De-assert	-	-	-28	dBm	-
LOS Hysteresis	-	0.5	-	dB	-

- Notes:**
- At 10^{-12} BER, PRS $2^{23}-1$, OC-48

Digital Diagnostics

Parameter	Range	Accuracy	Unit	Notes
Temperature	-40 to 102	± 3	$^{\circ}\text{C}$	-
Voltage	0 to V_{CC}	± 0.1	V	-
Bias Current	0 to 120	± 5	mA	-
TX Power	0 to 4	± 3	dBm	-
RX Power	-32 to -9	± 3	dBm	-
TEC Current	-1200 to 1200	± 60	mA	-
TEC Temperature	20 to 70	± 0.25	$^{\circ}\text{C}$	1

- Notes:**
- Relative accuracy. Absolute accuracy is $\pm 3^{\circ}\text{C}$

Datasheet

General Operating

Parameter	Symbol	Min.	Max.	Unit	Notes
Supply Voltage	V_{CC}	3.135	3.465	V	-
Total Current (BOL)	I_{CC}	-	375	mA	-
Power Supply Noise Rejection ^a	PSR	100	-	mV _{p-p}	1
Operating Temperature (case)	T_{op}	-5	70	°C	-
Storage Temperature	T_{st}	-40	85	°C	-
Data Rate Multirate	MR	100	2700	Mbps	-

Notes: 1. 20 Hz to 155 MHz

Electrical Transmitter Specifications

Parameter	Symbol	Min	Max	Unit	Notes
Input Differential Impedance	R_{in}	80	120	Ω	-
PECL Single-Ended Data Input Swing	$V_{in,p-p}$	250	1200	mV	-
TxFault_Fault	V_{fault}	2	V_{CC}	V	-
TxFault_Normal	V_{normal}	V_{EE}	$V_{EE}+0.5$	V	-
TxDisable_Disable	V_d	2	V_{CC}	V	-
TxDisable_Enable	V_{en}	V_{EE}	$V_{EE}+0.8$	V	-

Electrical Output

Parameter	Symbol	Min	Max	Unit	Notes
Single-Ended Data Output	$V_{out,p-p}$	185	800	mV	-
Data Output Rise Time	t_r	-	175	ps	-
Data Output Fall Time	t_f	-	175	ps	-

Timing and Electrical

Parameter	Symbol	Min	Max	Unit	Notes
Tx Disable Negate Time	t_{on}	-	20	ms	-
Tx Disable Assert Time	t_{off}	-	20	ms	-
Time to Initialize, after Reset of Tx_Fault/INT in Normal Operation	t_{init}	-	300	ms	-
Start-up Time	$t_{startup}$	-	90	secs	-
Tx Fault/INT Assert Time	t_{fault}	-	50	ms	-
Tx Disable to Reset	t_{reset}	10	-	μ s	-
LOS Assert Time	t_{loss_on}	-	100	μ s	-
LOS De-assert Time	t_{loss_off}	-	100	μ s	-
Serial ID Clock Rate	f_{serial_clock}	-	100	KHz	-
RX_LOS Voltage (High)	-	2	-	V	-
RX_LOS Voltage (Low)	-	-	0.8	V	-
LOS Output Voltage-Fault	$V_{LOS\ fault}$	2	V_{CC}	V	-
LOS Output Voltage-Normal	$V_{LOS\ normal}$	V_{EE}	$V_{EE}+0.55$	V	-
MOD_DEF (0:2)-High	V_H	2	V_{CC}	V	-
MOD_DEF (0:2)-Low	V_L	V_{EE}	$V_{EE}+0.5$	V	-

Datasheet

Pin	Function	Notes
1	V _{ee} T	TX Ground
2	TX_FAULT/INT	Open Collector
3	TX_DISABLE	Internally Pulled High
4	MOD_DEF2	Serial Data Input
5	MOD_DEF1	Serial Clock Input
6	MOD_DEF0	Internally Grounded
7	NC	Not Connected
8	LOS	Open Collector
9	V _{ee} R	RX Ground
10	V _{ee} R	RX Ground
11	V _{ee} R	RX Ground
12	RXD-	RX Data Negative
13	RXD+	RX Data Positive
14	V _{ee} R	RX Ground
15	V _{cc} R	RX Power
16	V _{cc} T	TX Power
17	V _{ee} T	TX Ground
18	TXD+	TX Data Positive
19	TXD-	TX Data Negative
20	V _{ee} T	TX Ground

DWDM Channel Guide (ITU C-Band)

ITU Channel (xx)	Frequency (THz)	Wavelength (nm)	ITU Channel (xx)	Frequency (THz)	Wavelength (nm)
17	191.7	1563.86	40	194.0	1545.32
18	191.8	1563.05	41	194.1	1544.53
19	191.9	1562.23	42	194.2	1543.73
20	192.0	1561.42	43	194.3	1542.94
21	192.1	1560.61	44	194.4	1542.14
22	192.2	1559.79	45	194.5	1541.35
23	192.3	1558.98	46	194.6	1540.56
24	192.4	1558.17	47	194.7	1539.77
25	192.5	1557.36	48	194.8	1538.98
26	192.6	1556.55	49	194.9	1538.19
27	192.7	1555.75	50	195.0	1537.40
28	192.8	1554.94	51	195.1	1536.61
29	192.9	1554.13	52	195.2	1535.82
30	193.0	1553.33	53	195.3	1535.04
31	193.1	1552.52	54	195.4	1534.25
32	193.2	1551.72	55	195.5	1533.47
33	193.3	1550.92	56	195.6	1532.68
34	193.4	1550.12	57	195.7	1531.90
35	193.5	1549.32	58	195.8	1531.12
36	193.6	1548.51	59	195.9	1530.33
37	193.7	1547.72	60	196.0	1529.55
38	193.8	1546.92	61	196.1	1528.77
39	193.9	1546.12	-	-	-

Datasheet

Outline Drawing

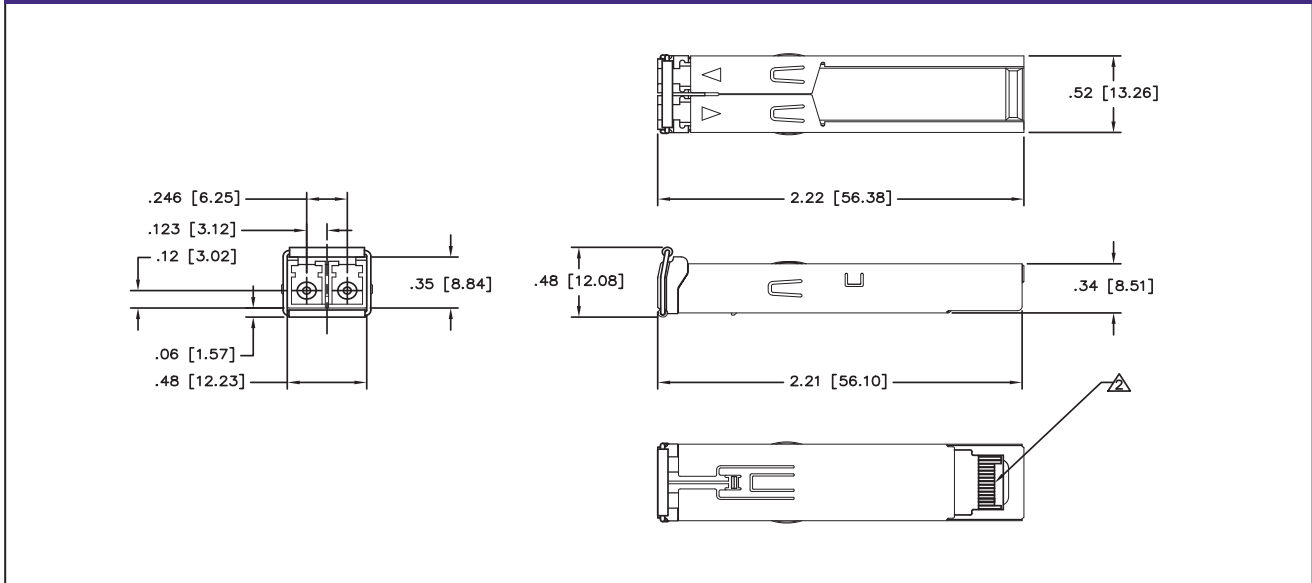

Ordering Information

Model	Description	Data Rate (Mbps)	Dispersion	Tx Channel	Link Range (km)
SFP27DWLR12-xx*	SFP Multirate DWDM Transceiver	100 - 2700	<2 dB (@ 2400 ps/nm)	xx*	40 - 120

* See DWDM C-band ITU grid for "xx" channels, wavelengths, and frequencies. L-band wavelengths are available by special order.

Regulatory and Industry Compliances

Class 1 Laser Product, complies with EN 60825-1 and 21 CFR 1040.10 except for deviations pursuant to Laser Notice No. 50. dated June 24, 2007
MSA SFF-8074i; Digital Diagnostic SFF-8472

Certified by one or more of the following agencies: TÜV, UL, CSA

RoHS Directive; China RoHS; California RoHS Law, REACH Directive SVHC; WEEE Directive

The Quality Management System is certified to ISO 9001 by QMI-SAI Global

The Environmental Management System is in compliance with ISO 14001

Warnings

Handling Precautions: This device is susceptible to damage as a result of electrostatic discharge (ESD). A static free environment is highly recommended. Follow guidelines according to proper ESD procedures.

Laser Safety: Radiation emitted by laser devices can be dangerous to human eyes. Avoid eye exposure to direct or indirect radiation.

MRV has more than 50 offices throughout the world. Addresses, phone numbers and fax numbers are listed at www.mrv.com.

Please e-mail us at info@mrv.com or call us for assistance.

MRV Los Angeles
20415 Nordhoff Street
Chatsworth, CA 91311
800-338-5316
818-773-0900

MRV Boston
300 Apollo Drive
Chelmsford, MA 01824
800-338-5316
978-674-6800

MRV International
Business Park Moerfelden
Waldeckerstrasse 13
64546 Moerfelden-Walldorf
Germany
Tel. (49) 6105/2070
Fax (49) 6105/207-100

All statements, technical information and recommendations related to the products herein are based upon information believed to be reliable or accurate. However, the accuracy or completeness thereof is not guaranteed, and no responsibility is assumed for any inaccuracies. Please contact MRV Communications for more information. MRV Communications and the MRV Communications logo are trademarks of MRV Communications, Inc. Other trademarks are the property of their respective holders.