

Datasheet

2 Gigabit Single-Mode 10 km SFP Transceivers

SFP-DGD-LX



Highlights

- SFP transceiver
- Data Rates: 1.0625 - 2.125 Gbps
- Protocols:
 - 1 Gbps Ethernet
 - 1 Gbps Fibre Channel
 - 2 Gbps Fibre Channel
- Single-mode fiber
- 1310 nm
- 0 to 10 km
- Duplex LC connector
- Digital Diagnostics (SFF-8472)
- Hot-swap
- Industrial temperature range

Overview

Small Form-Factor Pluggable (SFP) interfaces from MRV Communications provide flexible high speed links in a small industry standard package. They deliver the deployment options and inventory control that network administrators demand for growing networks.

SFPs are designed to Multi-Source Agreement (MSA) standards to ensure network equipment compatibility. They are a perfect addition to MRV's extensive lines of networking equipment.

Visit the MRV website at www.mrv.com or contact your nearest authorized MRV Communications dealer for more information.

Specifications Overview

Data Rate	1.0625 - 2.125 Gbps
Tx Wavelength	1310 nm
Tx Power (Minimum)	-9.5 dBm
Tx Disable	Yes
Rx Wavelength	1260 - 1600 nm
Rx Sensitivity	-21 dBm
Rx Saturation	0 dBm
Operating Temperature Range	-40 to 85 °C
Power Consumption	1 Watt

Datasheet

Optical Specifications					
Parameter	Symbol	Minimum	Maximum	Unit	Note
Transmitter					
Output Optical Power	P_{OUT}	-9.5	-3	dBm	1
Optical Wavelength	λ	1270	1360	nm	2
Spectral Width	σ	-	3	nm	2
Optical Modulation Amplitude	OMA	174	-	μ W	2,3
Optical Rise/Fall Time	t_r, t_f	-	160	ps	4
RIN	-	-	-120	dB/Hz	-
Deterministic Jitter Contribution	TX Δ DJ	-	56.5	ps	5
Total Jitter Contribution	TX Δ TJ	-	119	ps	-
Optical Extinction Ratio	ER	9	-	dB	-
Receiver					
Average Receiver Sensitivity @ 2.125 Gbps (2G Fibre Channel)	R_{SENSr}	-	-21	dBm	6, 7
Average Receiver Sensitivity @ 1.25 Gbps (1G Ethernet)	R_{SENS2}	-	-22	dBm	6, 7
Average Receiver Sensitivity @ 1.06 Gbps (1G Fibre Channel)	R_{SENS1}	-	-22	dBm	6, 7
Receiver Power	RX_{MAX}	-	0	dBm	-
Receiver Electrical 3 dB Cutoff Frequency	-	-	1500	MHz	-
Optical Center Wavelength	λ_C	1260	1600	nm	-
Return Loss	-	12	-	dB	-
LOS De-Assert	LOS_D	-	-19	dBm	-
LOS Assert	LOS_A	-30	-	dBm	-
LOS Hysteresis	-	0.5	-	dB	-

- Notes:**
1. Class 1 Laser Safety per FDA/CDRH and EN (IEC) 60825 regulations.
 2. Also specified to meet curves in FC-PI 13.0 Figures 18 and 19, which allow trade-off between wavelength, spectral width and OMA.
 3. Equivalent extinction ratio specification for Fibre Channel. Allows smaller ER at higher average power.
 4. Unfiltered, 20-80%. Complies with IEEE 802.3 (GbE)m FC 1G and 2G eye masks when filtered.
 5. Measured with DJ-free data input signal. In actual application, output DJ will be the sum of input DJ and Δ DJ.
 6. Measured with conformance signals defined in FC-PI 13.0 specifications.
 7. Measured with PRBS 2⁷-1 at 10⁻¹² BER.

Datasheet

Digital Diagnostics Specifications

Parameter	Symbol	Minimum	Maximum	Unit	Note
Accuracy					
Internally Measured Transceiver Temperature	DD _{Temperature}	-	± 3	°C	-
Internally Measured Transceiver Supply Voltage	DD _{Voltage}	-	± 100	mV	-
Measured TX Bias Current	DD _{Bias}	-	± 10	%	1
Measured TX Output Power	DD _{Tx-Power}	-	± 2	dB	-
Measured RX Received Average Optical Power	DD _{Rx-Power}	-	± 2	dB	-
Dynamic Range for Rated Accuracy					
Internally Measured Transceiver Temperature	DD _{Temperature}	-40	85	°C	-
Internally Measured Transceiver Supply Voltage	DD _{Voltage}	3.0	3.6	V	-
Measured TX Bias Current	DD _{Bias}	0	60	mA	-
Measured TX Output Power	DD _{Tx-Power}	-11.5	-1	dBm	-
Measured RX Received Average Optical Power	DD _{Rx-Power}	-23	2	dBm	-
Max Reporting Range					
Internally Measured Transceiver Temperature	DD _{Temperature}	-40	125	°C	-
Internally Measured Transceiver Supply Voltage	DD _{Voltage}	2.8	4.0	V	-
Measured TX Bias Current	DD _{Bias}	0	70	mA	-
Measured TX Output Power	DD _{Tx-Power}	-12.5	0	dBm	-
Measured RX Received Average Optical Power	DD _{Rx-Power}	-24	3	dBm	-

Notes: 1. Accuracy of Measured Tx Bias Current is 10% of the actual Bias Current from the laser driver to the laser.

General Specifications

Parameter	Symbol	Minimum	Maximum	Unit	Note
Data Rate	BR	1.0625	2.125	Gbps	1
Bit Error Rate	BER	-	10 ⁻¹²	-	2
Max. Supported Link Length on 9/125 µm SMF @ 1G and 2G Fibre Channel	L _{MAX2}	-	10	km	3, 4
Max. Supported Link Length on 9/125 µm SMF @ 1G Ethernet	L _{MAX3}	-	10	km	3, 4

Notes:

- 1G Ethernet and 1G/2G Fibre Channel compliant.
- Tested with a PRBS 2⁷-1 test pattern.
- Dispersion limited per FC-PI Rev. 13.
- Attenuation of 0.55 dB/km is used for the link length calculations. Distances are indicative only. Please refer to the Optical Specifications table to calculate a more accurate link budget based on specific conditions in your application.

Datasheet

Absolute Maximum Ratings*

Parameter	Symbol	Minimum	Maximum	Unit	Note
Maximum Supply Voltage	V_{CC}	-0.5	4.5	V	-
Case Operating Temperature	T_A	-40	85	°C	-
Storage Temperature	T_S	-40	100	°C	-
Relative Humidity (Non-Condensing)	RH	0	85	%	-

*Exceeding the limits listed in the table may damage the transceiver module permanently

Electrical Specifications

Parameter	Symbol	Minimum	Maximum	Unit	Note
Supply Voltage	V_{CC}	3.00	3.60	V	-
Supply Current	I_{CC}	-	300	mA	-
Transmitter					
Input Differential Impedance	R_{in}	80	120	Ω	1
Single Ended Data Input Swing	$V_{in, pp}$	250	1200	mV	-
Transmit Disable Voltage	V_D	$V_{CC} - 1.3$	V_{CC}	V	-
Transmit Enable Voltage	V_{EN}	V_{EE}	$V_{EE} + 0.8$	V	2
Transmit Disable Assert Time	-	-	10	us	-
Receiver					
Single Ended Data Output Swing	$V_{out, pp}$	300	800	mV	3
Data Output Rise Time	t_r	-	175	ps	4
Data Output Fall Time	t_f	-	175	ps	4
LOS Fault	$V_{LOS\ fault}$	$V_{CC} - 0.5$	$V_{CC\ HOST}$	V	5
LOS Normal	$V_{LOS\ norm}$	V_{EE}	$V_{EE} + 0.5$	V	5
Power Supply Rejection	PSR	100	-	mVpp	6
Deterministic Jitter Contribution	$RX \Delta DJ$	-	51.7	ps	7
Total Jitter Contribution	$RX \Delta TJ$	-	122.4	ps	-

- Notes:**
1. AC coupled.
 2. Or open circuit.
 3. Into 100 ohm differential termination.
 4. 20 – 80 %
 5. LOS is LVTTTL. Logic 0 indicates normal operation; logic 1 indicates no signal detected.
 6. All transceiver specifications are compliant with a power supply sinusoidal modulation of 20 Hz to 1.5 MHz up to specified value applied through the power supply filtering network shown on page 23 of the Small Form-factor Pluggable (SFP) Transceiver MultiSource Agreement (MSA)1, September 14, 2000.
 7. Measured with DJ-free data input signal. In actual application, output DJ will be the sum of input DJ and ΔDJ .

Datasheet

Pin Descriptions			
Pin	Function	Name/Description	Note
1	V _{EET}	Transmitter Ground (Common with Receiver Ground)	1
2	T _{FAULT}	Transmitter Fault. Not Supported.	-
3	T _{DIS}	Transmitter Disable. Laser Output Disabled on High or Open.	2
4	MOD_DEF(2)	Module Definition 2. Data Line for Serial ID.	3
5	MOD_DEF(1)	Module Definition 1. Clock Line for Serial ID.	3
6	MOD_DEF(0)	Module Definition 0. Grounded Within the Module.	3
7	Rate Select	No Connection Required.	4
8	LOS	Loss of Signal Indication. Logic 0 Indicates Normal Operation.	5
9	V _{EER}	Receiver Ground (Common with Transmitter Ground)	1
10	V _{EER}	Receiver Ground (Common with Transmitter Ground)	1
11	V _{EER}	Receiver Ground (Common with Transmitter Ground)	1
12	RD-	Receiver Inverted DATA Out. AC Coupled.	
13	RD+	Receiver Non-Inverted DATA Out. AC Coupled.	
14	V _{EER}	Receiver Ground (Common with Transmitter Ground)	1
15	V _{CCR}	Receiver Power Supply	
16	V _{CCT}	Transmitter Power Supply	
17	V _{EET}	Transmitter Ground (Common with Receiver Ground)	1
18	TD+	Transmitter Non-Inverted DATA In. AC Coupled.	
19	TD-	Transmitter Inverted DATA In. AC Coupled.	
20	V _{EET}	Transmitter Ground (Common with Receiver Ground)	1

- Notes:**
1. Circuit ground is internally isolated from chassis ground.
 2. Laser output disabled on T_{DIS} > 2.0 V or open, enabled on T_{DIS} < 0.8 V.
 3. Should be pulled up with 4.7 k - 10 kohms on host board to a voltage between 2.0 V and 3.6 V. MOD_DEF(0) pulls line low to indicate module is plugged in.
 4. Transceivers operate at 1G and 2G Fibre Channel, and Gigabit Ethernet data rates and respective protocols without active control.
 5. LOS is open collector output. Should be pulled up with 4.7k – 10 kohms on host board to a voltage between 2.0 V and 3.6 V. Logic 0 indicates normal operation; logic 1 indicates loss of signal.

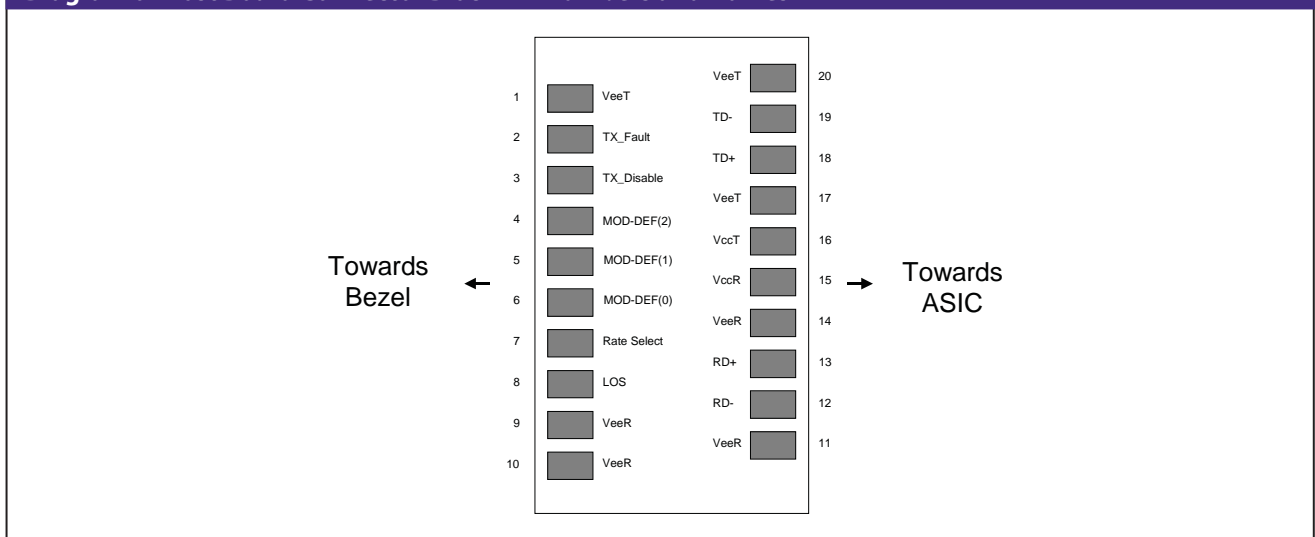
Diagram of Host Board Connector Block Pin Numbers and Names

Datasheet

Mechanical Dimensions

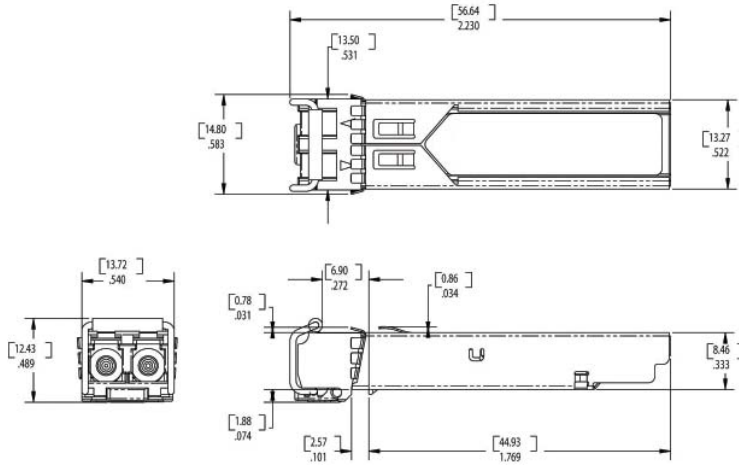

Ordering Information

Model	Description	Data Rate (Gbps)	Wavelength (nm)	Connector	Bail Latch Color	Maximum Distance Range (km)
SFP-DGD-LX	1 Gbps Ethernet and 1/2 Gbps Fibre Channel SFP Transceiver	1.0625 - 2.125	1310	Duplex LC	Blue	0 -10

Regulatory and Industry Compliances

Class 1 Laser Product, complies with EN 60825-1 and 21 CFR 1040.10 except for deviations pursuant to Laser Notice No. 50. dated June 24, 2007
MSA SFF-8074i; Digital Diagnostic SFF-8472

Certified by one or more of the following agencies: TÜV, UL, CSA

RoHS Directive; China RoHS; California RoHS Law, REACH Directive SVHC; WEEE Directive

The Quality Management System is certified to ISO 9001 by QMI-SAI Global

The Environmental Management System is in compliance with ISO 14001

Warnings

Handling Precautions: This device is susceptible to damage as a result of electrostatic discharge (ESD). A static free environment is highly recommended. Follow guidelines according to proper ESD procedures.

Laser Safety: Radiation emitted by laser devices can be dangerous to human eyes. Avoid eye exposure to direct or indirect radiation.

MRV has more than 50 offices throughout the world. Addresses, phone numbers and fax numbers are listed at www.mrv.com. Please e-mail us at info@mrv.com or call us for assistance.

MRV Los Angeles
20415 Nordhoff Street
Chatsworth, CA 91311
800-338-5316
818-773-0900

MRV Boston
300 Apollo Drive
Chelmsford, MA 01824
800-338-5316
978-674-6800

MRV International
Business Park Moerfelden
Waldeckerstrasse 13
64546 Moerfelden-Walldorf
Germany
Tel. (49) 6105/2070
Fax (49) 6105/207-100

All statements, technical information, and recommendations related to the products herein are based upon information believed to be reliable or accurate. However, the accuracy or completeness thereof is not guaranteed, and no responsibility is assumed for any inaccuracies. Please contact MRV Communications for more information. MRV Communications and the MRV Communications logo are trademarks of MRV Communications, Inc. Other trademarks are the property of their respective holders.