

Datasheet

## 622 Mbps Dual Rate Single-Mode 25 km SFP Transceivers

SFP-DRO12D-IR1



### Features

- SFP transceiver
- Data Rates: 155 to 622 Mbps
- Protocols:
  - SONET OC-3/SDH STM-1
  - SONET OC-12/SDH STM-4
- Single-mode fiber
- 1310 nm
- 0 to 25 km
- Duplex LC connector
- Digital Diagnostics (SFF-8472)
- Hot-swap

### Overview

Small Form-Factor Pluggable (SFP) interfaces from MRV Communications provide flexible high speed links in a small industry-standard package. They deliver the deployment options and inventory control that network administrators demand for growing networks.

SFPs are designed to Multi-Source Agreement (MSA) standards to ensure network equipment compatibility. They are a perfect addition to MRV’s extensive lines of networking equipment.

Visit the MRV website at [www.mrv.com](http://www.mrv.com) or contact your nearest authorized MRV Communications dealer for more information.

### Specifications Overview

Data Rate	155 to 622 Mbps
Tx Wavelength	1310 nm
Tx Power (Minimum)	-15 dBm
Tx Dispersion Penalty	1 dB
Tx Disable	Yes
Rx Wavelength Range	1260 - 1580 nm
Rx Sensitivity	-28 dBm
Rx Saturation	-8 dBm
Operating Temperature Range	0 to 70 °C
Power Consumption	1 Watt

## Datasheet

### Transmitter Specifications, Optical

Parameter	Symbol	Minimum	Maximum	Unit	Note
Centre Wavelength	$\lambda_C$	1274	1356	nm	-
Average Output Power	$P_{OUT}$	-15	-8	dBm	1
Spectral Width (RMS)	$\Delta\lambda$	-	2.5	nm	-
Extinction Ratio	EX	8.2	-	dB	-
Jitter Generation (RMS)	-	-	0.01	UI	-
Jitter Generation (pk-pk)	-	-	0.1	UI	-
Optical Eye Mask	-	Compatible with Telcordia GR-253-CORE and ITU-T G.957			2

- Notes:**
- The optical power is launched into SMF.
  - Measured with a PRBS 2<sup>23</sup>-1 test pattern @155/622 Mbps.

### Receiver Specifications, Optical

Parameter	Symbol	Minimum	Maximum	Unit	Note
Centre Wavelength	$\lambda_C$	1260	1580	nm	-
Receiver Sensitivity	$P_{IN}$	-	-28	dBm	1
Receiver Overload	$P_{IN}$	-8	-	dBm	1
Optical Path Penalty	-	-	1	dB	2
LOS Assert	$LOS_A$	-42	-	dBm	-
LOS De-Assert	$LOS_D$	-	-31	dBm	-
LOS Hysteresis	-	1	4	dB	-

- Notes:**
- Measured with a PRBS 2<sup>23</sup>-1 test pattern @155/622 Mbps, BER  $\leq 1 \times 10^{-10}$ .
  - Measured with a PRBS 2<sup>23</sup>-1 test pattern @155/622 Mbps, over 15 km G.652 SMF, BER  $\leq 1 \times 10^{-10}$ .

### Monitoring Specifications

Parameter	Range	Unit	Accuracy	Calibration
Temperature	-10 to 80	°C	$\pm 3^\circ\text{C}$	Internal
Voltage	3 to 3.6	V	$\pm 3\%$	Internal
Bias Current	0 to 100	mA	$\pm 10\%$	External
Tx Power	-16 to -7	dBm	$\pm 3\text{ dB}$	External
Rx Power	-30 to -7	dBm	$\pm 3\text{ dB}$	External

### Transmitter Specifications, Electrical

Parameter	Symbol	Minimum	Maximum	Unit	Note
Data Input Swing Differential	$V_{IN}$	500	2400	mV	1
Input Differential Impedance	$Z_{IN}$	90	110	$\Omega$	-
Tx_DIS Disable	$V_D$	2.0	$V_{CC}$	V	-
Tx_DIS Enable	$V_{EN}$	GND	GND + 0.8	V	-
Tx_Fault (Fault)	-	2.0	$V_{CC} + 0.3$	V	-
Tx_Fault (Normal)	-	0	0.8	V	-

- Notes:**
- Internally AC coupled

### Receiver Specifications, Electrical

Parameter	Symbol	Minimum	Maximum	Unit	Note
Data Output Swing Differential	$V_{OUT}$	370	2000	mV	1
Rx_LOS Fault	$V_{LOSS-Fault}$	2.0	$V_{CC} + 0.3$	V	-
Rx_LOS Normal	$V_{LOSS-Normal}$	GND	GND + 0.8	V	-

- Notes:**
- Internally AC coupled

## Datasheet

### Recommended Operating Conditions

Parameter	Symbol	Minimum	Maximum	Unit	Note
Operating Case Temperature	$T_C$	-5	70	°C	-
Power Supply Voltage	$V_{CC}$	3.13	3.47	V	-
Power Supply Current	$I_{CC}$	-	300	mA	-
Power dissipation	$P_D$	-	1	W	-
Data Rate	DR	155	622	Mbps	-

### Pin Descriptions

Pin	Function	Name/Description	Plug Seq.	Note
1	VeeT	Transmitter Ground	1	-
2	Tx Fault	Transmitter Fault Indication	3	1
3	Tx Disable	Transmitter Disable	3	2
4	MOD-DEF2	Module Definition 2	3	3
5	MOD-DEF1	Module Definition 1	3	3
6	MOD-DEF0	Module Definition 0	3	3
7	Rate Select	Not Connected	3	-
8	LOS	Loss of Signal Indication	3	4
9	VeeR	Receiver Ground	1	-
10	VeeR	Receiver Ground	1	-
11	VeeR	Receiver Ground	1	-
12	RD-	Inverted Received Data Out	3	5
13	RD+	Received Data Out	3	5
14	VeeR	Receiver Ground	1	-
15	VccR	Receiver Power	2	-
16	VccT	Transmitter Power	2	-
17	VeeT	Transmitter Ground	1	-
18	TD+	Transmitter Data In	3	6
19	TD-	Inverted Transmitter Data In	3	6
20	VeeT	Transmitter Ground	1	-

- Notes:**
- TX Fault is an open collector output, which should be pulled up with a 4.7 k~10 kΩ resistor on the host board to a voltage between 2.0 V and  $V_{CC}+0.3V$ . Logic 0 indicates normal operation; logic 1 indicates a laser fault of some kind. In the low state, the output will be pulled to less than 0.8 V.
  - TX Disable is an input that is used to shut down the transmitter optical output. It is pulled up within the module with a 4.7 k~10 kΩ resistor. Its states are:  
 Low (0~0.8 V): Transmitter on  
 (>0.8V, <2.0V): Undefined  
 High (2.0~3.465V): Transmitter Disabled  
 Open: Transmitter Disabled
  - MOD-DEF 0,1,2 are the module definition pins. They should be pulled up with a 4.7 k~10 kΩ resistor on the host board. The pull-up voltage shall be  $V_{CC}$  or  $V_{CCR}$ .  
 MOD-DEF 0 is grounded by the module to indicate that the module is present  
 MOD-DEF 1 is the clock line of two wires serial interface for serial ID  
 MOD-DEF 2 is the data line of two wires serial interface for serial ID
  - LOS is an open collector output, which should be pulled up with a 4.7 k~10 kΩ resistor on the host board to a voltage between 2.0 V and  $V_{CC}+0.3V$ . Logic 0 indicates normal operation; logic 1 indicates loss of signal. In the low state, the output will be pulled to less than 0.8 V.
  - These are the differential receiver output. They are internally AC-coupled 100 Ω differential lines which should be terminated with 100 Ω (differential) at the user SERDES.
  - These are the differential transmitter inputs. They are AC-coupled, differential lines with 100 Ω differential termination inside the module.

# Datasheet

## Mechanical Dimensions

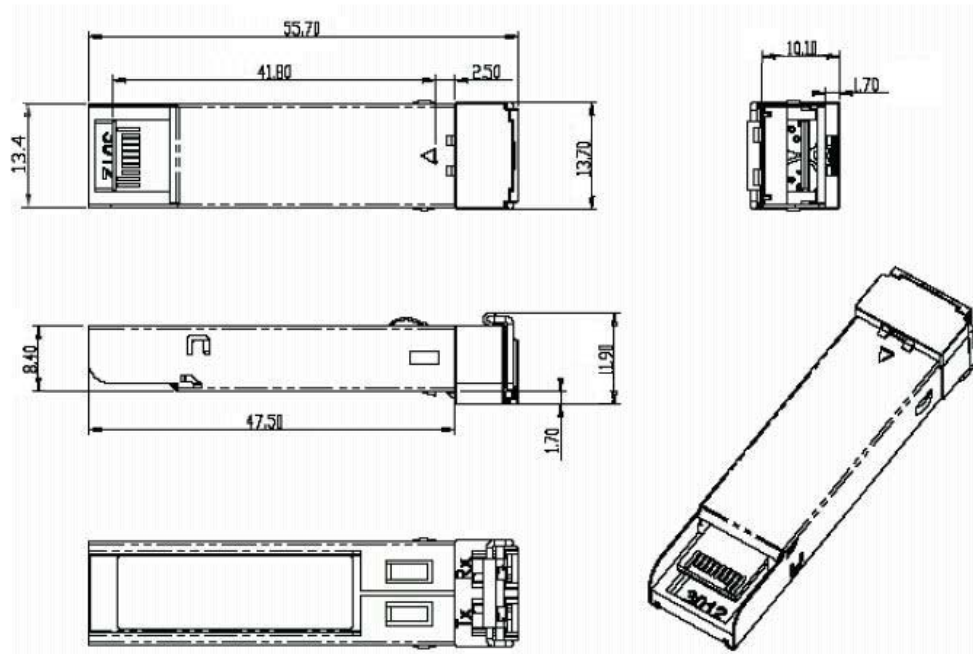

## Datasheet

### Ordering Information

Model	Description	Data Rate (Mbps)	Wavelength (nm)	Connector	Bail Latch Color	Digital Diagnostics	Maximum Distance Range (km)*
SFP-DRO12D-IR1	SDH STM-1, SONET OC-3, SDH STM-4, SONET OC-12 SFP Transceiver	155 - 622	1310	Duplex LC	Gray	Yes	0 - 25

\* Maximum range quoted is not possible with all wavelength and/or fiber. Please consult MRV.

### Regulatory and Industry Compliances

Class 1 Laser Product, complies with EN 60825-1 and 21 CFR 1040.10 except for deviations pursuant to Laser Notice No. 50. dated June 24, 2007  
MSA SFF-8074i; Digital Diagnostic SFF-8472

Certified by one or more of the following agencies: TÜV, UL, CSA

RoHS Directive; China RoHS; California RoHS Law, REACH Directive SVHC; WEEE Directive

The Quality Management System is certified to ISO 9001 by QMI-SAI Global

The Environmental Management System is in compliance with ISO 14001

### Warnings

**Handling Precautions:** This device is susceptible to damage as a result of electrostatic discharge (ESD). A static free environment is highly recommended. Follow guidelines according to proper ESD procedures.

**Laser Safety:** Radiation emitted by laser devices can be dangerous to human eyes. Avoid eye exposure to direct or indirect radiation.

MRV has more than 50 offices throughout the world. Addresses, phone numbers and fax numbers are listed at [www.mrv.com](http://www.mrv.com).  
Please e-mail us at [info@mrv.com](mailto:info@mrv.com) or call us for assistance.

MRV Los Angeles  
20415 Nordhoff Street  
Chatsworth, CA 91311  
800-338-5316  
818-773-0900

MRV Boston  
300 Apollo Drive  
Chelmsford, MA 01824  
800-338-5316  
978-674-6800

MRV International  
Business Park Moerfelden  
Waldeckerstrasse 13  
64546 Moerfelden-Walldorf  
Germany  
Tel. (49) 6105/2070  
Fax (49) 6105/207-100

All statements, technical information, and recommendations related to the products herein are based upon information believed to be reliable or accurate. However, the accuracy or completeness thereof is not guaranteed, and no responsibility is assumed for any inaccuracies. Please contact MRV Communications for more information. MRV Communications and the MRV Communications logo are trademarks of MRV Communications, Inc. Other trademarks are the property of their respective holders.