

Datasheet

## 5 Gbps Multi-Rate 80 km CWDM SFP Transceiver

SFPFC4CW08-xx\*



### Highlights

- SFP transceiver
- Data Rates: 0.155 to 5 Gbps
- Protocols:
  - 1/2/4 Gbps Fibre Channel
  - 1 Gigabit Ethernet
- Single-mode fiber
- CWDM wavelength per ITU-T G.694.2
- 30 - 84 km
- Duplex LC connector
- Digital Diagnostics (SFF-8472)
- Hot-swap

### Overview

Small Form-Factor Pluggable (SFP) interfaces from MRV Communications provide flexible high speed links in a small industry standard package. They deliver the deployment options and inventory control that network administrators demand for growing networks.

SFPs are designed to Multi-Source Agreement (MSA) standards to ensure network equipment compatibility. They are a perfect addition to MRV’s extensive lines of networking equipment.

Visit the MRV website at [www.mrv.com](http://www.mrv.com) or contact your nearest authorized MRV Communications dealer for more information.

Specifications Overview	
Data Rate	0.155 - 5 Gbps
Tx Wavelength	CWDM wavelength (see Wavelength Guide for xx values)
Tx Power (Minimum)	0 dBm
Tx Dispersion Penalty	3 dB
Tx Disable	Yes
Tx Extinction Ratio	5 dB
Rx Wavelength	1200 - 1625 nm
Rx Sensitivity	-24 dBm
Rx Saturation	-6 dBm
Rx Damage Threshold	4 dBm
Operating Temperature Range	-5 to 70 °C
Power Consumption	1 Watt

\* See Wavelength Guide for xx values

## Datasheet

### Optical Transmitter Specifications

Parameter	Symbol	Minimum	Maximum	Unit	Note
Optical Power	P <sub>op</sub>	0	5	dBm	-
Average Launch Power of Tx_Off	P <sub>off</sub>	-	-45	dBm	-
Extinction Ratio	ER	5	-	dB	-
Eye Mask	-	Fibre Channel Compliant			-
Optical Rise/Fall Time	t <sub>r</sub> /t <sub>f</sub>	-	130	ps	1
Mean Wavelength	λ	1xx1 - 6.5 nm	1xx1 + 6.5 nm	nm	-
Spectral Width (20 dB)	Δλ <sub>20</sub>	-	1	nm	-
Dispersion Penalty (@ 80 km)	dp	-	3	dB	2
Relative Intensity Noise	RIN	-	-120	dB/Hz	-
Reflection Tolerance	rp	-24	-	dB	3

- Notes:**
1. 80% -20% values
  2. Measured at BER of 1e<sup>-12</sup>, PRBS of 2<sup>7</sup>-1, at eye center, 4.25 Gbps, 80 km
  3. 1 dB degradation of receiver sensitivity

### Optical Receiver Specifications

Parameter	Symbol	Minimum	Maximum	Unit	Note
Receive Power	R <sub>sens, low/high</sub>	-24	-6	dBm	1
Damage Threshold	P <sub>in, damage</sub>	4	-	dBm	-
Wavelength	λ	1200	1625	nm	-
Receiver Reflectance	RX_r	-	-27	dB	-
LOS Assert	-	-34	-	dBm	-
LOS De-Assert	-	-	-24	dBm	-
LOS Hysteresis	-	0.5	-	dB	-

- Notes:**
1. Measured at 10<sup>-12</sup> BER, PRBS 2<sup>7</sup>-1

### Digital Diagnostics

Parameter	Range	Accuracy	Unit	Calibration	Formula
Temperature	-5 to 70	± 3	°C	External	T <sub>c</sub> (C)=T <sub>slope</sub> *T <sub>ad</sub> (16 bit signed twos complement value) + T <sub>offset</sub>
Voltage	0 to V <sub>CC</sub>	± 0.1	V	External	V(Volts)=V <sub>slope</sub> *V <sub>ad</sub> (16 bit unsigned integer)+V <sub>offset</sub>
Bias Current	0 to 120	± 5	mA	External	I(mA)=I <sub>slope</sub> *I <sub>ad</sub> (16 bit unsigned integer)+I <sub>offset</sub>
TX Power	0 to 5	± 3	dBm	External	TX_PWR(μW)=TX_PWR <sub>slope</sub> *TX_PWR <sub>ad</sub> (16 bit unsigned integer)+TX_PWR <sub>offset</sub>
RX Power	-24 to -6	± 3	dBm	External	RX_PWR(μW)=A <sub>0</sub> +A <sub>1</sub> *x+A <sub>2</sub> *x <sup>2</sup> +A <sub>3</sub> *x <sup>3</sup> +A <sub>4</sub> *x <sup>4</sup>

## Datasheet

### General Operating Conditions

Parameter	Symbol	Minimum	Maximum	Unit	Note
Supply Voltage	$V_{CC}$	3.135	3.465	V	-
Total Current	$I_{CC}$	-	300	mA	-
Power Supply Noise Rejection	PSR	100	-	mV <sub>p-p</sub>	1
Operating Case Temperature	$T_{op}$	-5	70	°C	-
Storage Temperature	$T_{st}$	-40	85	°C	-
Data Rate	DR	0.155	5	Gbps	-

**Notes:** 1. 20 Hz to 155 MHz

### Electrical Transmitter Specifications

Parameter	Symbol	Min	Max	Unit	Note
Input Differential Impedance	$R_{in}$	80	120	$\Omega$	-
PECL Single-Ended Data Input Swing	$V_{in,p-p}$	250	1200	mV	-
TxFault_Fault	$V_{fault}$	2	$V_{CC}$	V	-
TxFault_Normal	$V_{normal}$	$V_{EE}$	$V_{EE} + 0.5$	V	-
TxDisable_Disable	$V_d$	2	$V_{CC}$	V	-
TxDisable_Enable	$V_{en}$	$V_{EE}$	$V_{EE} + 0.8$	V	-

### Electrical Receiver Specifications

Parameter	Symbol	Min	Max	Unit	Note
PECL Single-Ended Data Output Swing	$V_{out,p-p}$	185	800	mV	-
Data output rise time	$t_r$	-	175	ps	-
Data output fall time	$t_f$	-	175	ps	-

### Timing and Electrical Specifications

Parameter	Symbol	Min	Max	Unit	Note
TX_DISABLE Negate Time	$t_{on}$	-	50	$\mu$ s	-
TX_DISABLE Assert Time	$t_{off}$	-	10	$\mu$ s	-
Time to Initialize, Including Reset of Tx Fault	$t_{init}$	-	200	ms	-
Tx_FAULT Assert Time	$t_{fault}$	-	100	$\mu$ s	-
TX_DISABLE Reset Time	$t_{reset}$	10	-	$\mu$ s	-
RX_LOS Assert Time	$t_{loss\_on}$	-	100	$\mu$ s	-
RX_LOS De-Assert Time	$t_{loss\_off}$	-	100	$\mu$ s	-
Serial ID Clock Rate	$f_{serial\_clock}$	2	100	KHz	-
RX_LOS Voltage (High)	-	2	$V_{CC}$	V	-
RX_LOS Voltage (Low)	-	-	0.8	V	-
LOS Output Voltage-Fault	$V_{LOS\ fault}$	2	$V_{CC}$	V	-
LOS Output Voltage-Normal	$V_{LOS\ normal}$	$V_{EE}$	$V_{EE} + 0.5$	V	-
MOD_DEF (0:2)-High	$V_H$	2	$V_{CC}$	V	-
MOD_DEF (0:2)-Low	$V_L$	$V_{EE}$	$V_{EE} + 0.5$	V	-

**Datasheet**

Pin	Function	Name / Description	Notes
1	V <sub>eeT</sub>	Module Transmitter Ground	-
2	TX_FAULT	Open Collector	-
3	TX_DISABLE	Internally Pulled High	-
4	MOD_DEF2	Serial Data Input	-
5	MOD_DEF1	Serial Clock Input	-
6	MOD_DEF0	Internally Grounded	-
7	NC	Not Connected	-
8	LOS	Open Collector	-
9	V <sub>eeR</sub>	Module Receiver Ground	-
10	V <sub>eeR</sub>	Module Receiver Ground	-
11	V <sub>eeR</sub>	Module Receiver Ground	-
12	RXD-	Receiver Data Negative	-
13	RXD+	Receiver Data Positive	-
14	V <sub>eeR</sub>	Module Receiver Ground	-
15	V <sub>ccR</sub>	Module Receiver Power Supply	-
16	V <sub>ccT</sub>	Module Transmitter Power Supply	-
17	V <sub>eeT</sub>	Module Transmitter Ground	-
18	TXD+	Transmitter Data Positive	-
19	TXD-	Transmitter Data Negative	-
20	V <sub>eeT</sub>	Module Transmitter Ground	-

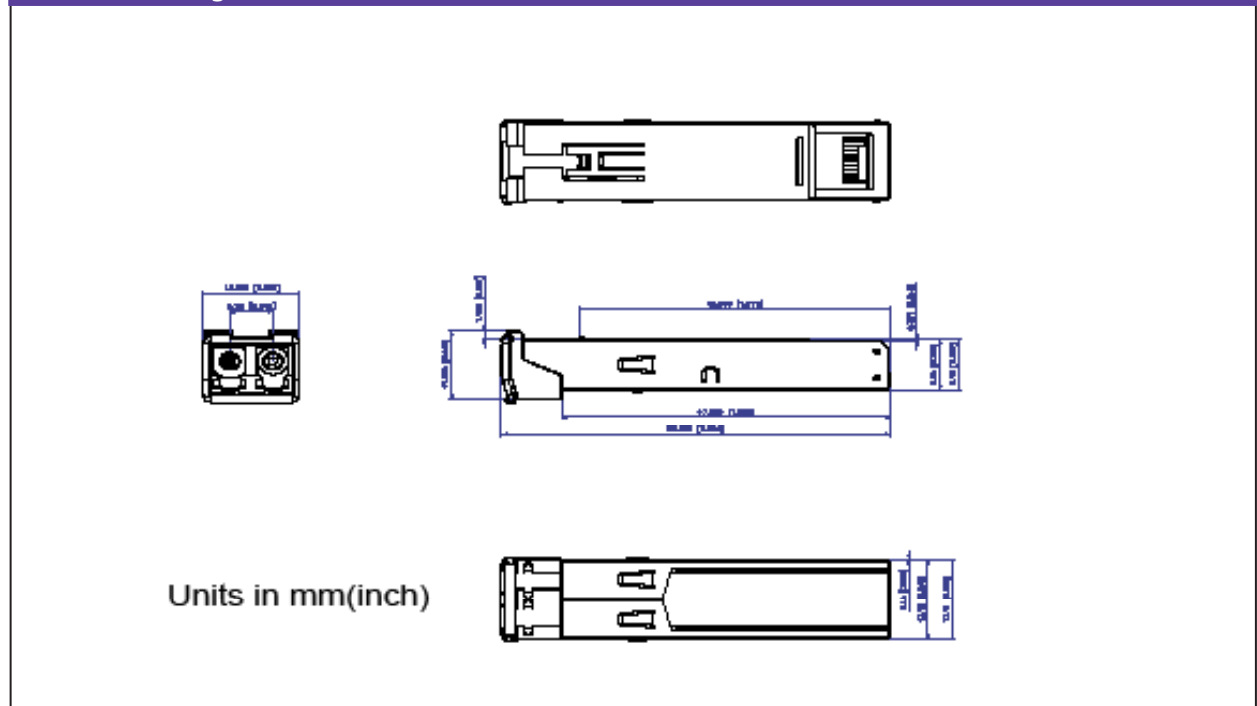
**Outline Drawing**

## Datasheet

### Ordering Information

Model	Description	Data Rate (Mbps)	Digital Diagnostics	Bail Latch Color	Distance Range (km)
SFPFC4CW08-xx*	SFP Multi-Rate CWDM SFP Transceiver	1/2/4 Gbps Fibre Channel 1/2 Gigabit Ethernet	Yes	Yellow	30 - 84

\* See Wavelength Guide below for "xx" values

### λc Wavelength Guide

Code (xx)	λc	Unit	Code (xx)	λc	Unit	Code (xx)	λc	Unit
27	1271	nm	39	1391	nm	51	1511	nm
29	1291	nm	41	1411	nm	53	1531	nm
31	1311	nm	43	1431	nm	55	1551	nm
33	1331	nm	45	1451	nm	57	1571	nm
35	1351	nm	47	1471	nm	59	1591	nm
37	1371	nm	49	1491	nm	61	1611	nm

### Regulatory and Industry Compliances

Class 1 Laser Product, complies with EN 60825-1 and 21 CFR 1040.10 except for deviations pursuant to Laser Notice No. 50. dated June 24, 2007  
MSA SFF-8074i; Telecordia GR-468; Digital Diagnostic SFF-8472  
Certified by one or more of the following agencies: TÜV, UL, CSA  
RoHS Directive; China RoHS; California RoHS Law, REACH Directive SVHC; WEEE Directive  
The Quality Management System is certified to ISO 9001 by QMI-SAI Global  
The Environmental Management System is in compliance with ISO 14001

### Warnings

**Handling Precautions:** This device is susceptible to damage as a result of electrostatic discharge (ESD). A static free environment is highly recommended. Follow guidelines according to proper ESD procedures.

**Laser Safety:** Radiation emitted by laser devices can be dangerous to human eyes. Avoid eye exposure to direct or indirect radiation.

MRV operates Worldwide sales and service offices across four continents.

Contact us at [info@mrv.com](mailto:info@mrv.com)

**MRV Communications**  
Corporate Headquarters  
300 Apollo Drive  
Chelmsford, MA 01824

<http://www.mrv.com>



All statements, technical information and recommendations related to the products herein are based upon information believed to be reliable or accurate. However, the accuracy or completeness thereof is not guaranteed, and no responsibility is assumed for any inaccuracies. Please contact MRV Communications for more information. MRV Communications and the MRV Communications logo are trademarks of MRV Communications, Inc. Other trademarks are the property of their respective holders.