

**Datasheet**

## 4.25 Gbps Multi-Rate 40 km DWDM SFP Transceiver

SFPFC4DW04-xx



### Highlights

- SFP transceiver
- C-band wavelengths on the 100 GHz (0.8 nm) DWDM ITU grid
- Data Rates: 1.0625 to 4.25 Gbps
- Protocols:
  - 1/2/4 Gbps Fibre Channel
  - 1 Gigabit Ethernet
- Single-mode fiber
- 10 - 40 km
- Duplex LC connector
- Digital Diagnostics (SFF-8472)
- Hot-swap

### Overview

Small Form-Factor Pluggable (SFP) interfaces from MRV Communications provide flexible high speed links in a small industry standard package. They deliver the deployment options and inventory control that network administrators demand for growing networks.

SFPs are designed to Multi-Source Agreement (MSA) standards to ensure network equipment compatibility. They are a perfect addition to MRV’s extensive lines of networking equipment.

Visit the MRV website at [www.mrv.com](http://www.mrv.com) or contact your nearest authorized MRV Communications dealer for more information.

### Specifications Overview

Data Rate	1.0625 - 4.25 Gbps
Tx Wavelength	100 GHz ITU Grid, C-Band (See DWDM Wavelength Chart)
Tx Power (Minimum)	0 dBm
Tx Dispersion Penalty	2 dB
Tx Extinction Ratio	9 dB
Tx Disable	Yes
Rx Wavelength	1528 - 1564 nm
Rx Sensitivity @ 4.25 Gbps	-16 dBm
Rx Sensitivity @ 2.125 Gbps	-18 dBm
Rx Sensitivity @ 1.063 Gbps	-20 dBm
Rx Saturation	-3 dBm
Operating Temperature Range	-5 to 70 °C
Power Consumption	1 Watt

## Datasheet

### Optical Specifications

Parameter	Symbol	Minimum	Maximum	Unit	Note
Power Budget @ 9/125 μm SMF	-	-	16	dB	-
Data Rate	DR	1.0625	4.25	Gbps	-
<b>Transmitter</b>					
Wavelength	$\lambda$	1528	1564	nm	-
Spectral Width (-20 dB)	$\Delta\lambda$	-	0.3	nm	-
Side Mode Suppression Ratio	SMSR	30	-	dB	-
Deviation From Central Frequency, EOL	$\Delta f$	-	$\pm 12 (\pm 0.096)$	GHz (nm)	-
Output Power	$P_{out}$	0	4	dBm	1
Extinction Ratio	ER	9	-	dB	2
Rise/Fall Time (20%-80%)	$t_r, t_f$	-	90	ps	-
Output Optical eye	-	Compliant with ANSI FC-PI specification			2, 4
$P_{out@TX}$ Disable Asserted	$P_{out}$	-	-30	dBm	-
<b>Receiver</b>					
Center Wavelength	$\lambda_c$	1528	1564	nm	-
Sensitivity @ 4GFC	$P_{min}$	-	-16	dBm	3
Sensitivity @ 2GFC	$P_{min}$	-	-18	dBm	3
Sensitivity @ 1GFC	$P_{min}$	-	-20	dBm	3
Overload	$P_{max}$	-3	-	dBm	-
Maximum Reflectance of Receiver	$R_f$	-	-17	dB	-
Dispersion Penalty	$P_d$	-	2	dB	-
LOS De-Assert	$LOS_D$	-	-20	dBm	-
LOS Assert	$LOS_A$	-40	-	dBm	-
LOS Hysteresis	-	0.5	-	dB	-

- Notes:**
1. Output is coupled into a 9/125m single-mode fiber.
  2. Filtered, measured with a PRBS 2<sup>7</sup>-1 test pattern @4.25 Gbps
  3. Minimum average optical power measured at BER less than 1E-12, with a 2<sup>7</sup>-1 PRBS and ER = 9 dB.
  4. Eye Pattern Mask

### Digital Diagnostics Specifications

Parameter	Range	Accuracy	Unit	Note
Temperature	-5 to 70	$\pm 3$	°C	-
Voltage	0 to Vcc	$\pm 0.1$	V	-
Bias Current	0 to 120	$\pm 5$	mA	-
Tx Power	0 to 4	$\pm 2$	dBm	-
Rx Power	-16 to -3	$\pm 2$	dBm	-
TEC Current	-1200 to 1200	$\pm 60$	mA	-
TEC Temperature	20 to 70	$\pm 0.25$	°C	Relative, absolute accuracy is $\pm 3$ °C

## Datasheet

### Absolute Maximum Ratings

Parameter	Symbol	Minimum	Maximum	Unit	Note
Storage Temperature	$T_S$	-40	85	°C	-
Supply Voltage	$V_{CC}$	-0.5	3.6	V	-
Operating Relative Humidity	-	-	95	%	-

### Recommended Operating Conditions

Parameter	Symbol	Minimum	Maximum	Unit	Note
Operating Case Temperature	$T_A$	-5	70	°C	-
Power Supply Voltage	$V_{CC}$	3.15	3.45	V	-
Power Supply Current	$I_{CC}$	-	300	mA	-
Data Rate @ 4GFC	-	-	4.25	Gbps	-
Data Rate @ 2GFC	-	-	2.125	Gbps	-
Data Rate @ 1GFC	-	-	1.063	Gbps	-

### Electical Transmitter Specifications

Parameter	Symbol	Min	Max	Unit	Note
<b>Transmitter</b>					
LVPECL Inputs (Differential)	$V_{in}$	400	2000	mVpp	1
Input Impedance (Differential)	$Z_{in}$	85	115	ohm	2
TX_DISABLE Assert Time	$t_{off}$	-	10	us	-
TX_DIS Disable	-	2	$V_{CC} + 0.3$	V	-
TX_DIS Enable	-	0	0.8	V	-
TX_FAULT Fault	-	2	$V_{CC} + 0.3$	V	-
TX_FAULT Normal	-	0	0.5	V	-
<b>Receiver</b>					
CML Outputs (Differential)	$V_{out}$	400	1200	mVpp	3
Output Impedance (Differential)	$Z_{out}$	85	115	ohm	-
RX_LOS Los	-	2	$V_{CC} + 0.3$	V	-
RX_LOS Normal	-	0	0.8	V	-
MOD_DEF (0:2)-High	VoH	2.5	-	V	-
MOD_DEF (0:2)-Low	VoL	0	0.5	V	4

- Notes:**
1. AC coupled input
  2.  $R_{in} > 100 \text{ kohm}$  @ DC
  3. CML logic, internally AC coupled output
  4. With Serial ID

## Datasheet

### Pin Descriptions

Pin	Name	Description	Plug Sequence	Note
1	VeeT	Transmitter Ground	1	5
2	TX_FAULT	Transmitter Fault Indication	3	1
3	TX_DISABLE	Transmitter Disable. Module disables on high or open	3	2
4	MOD-DEF2	Module Definition 2. Data line for Serial ID	3	3
5	MOD-DEF1	Module Definition 1. Clock line for Serial ID	3	3
6	MOD-DEF0	Module Definition 0. Grounded within the module	3	3
7	Rate Select	Not connected. Function not available	3	-
8	LOS	Loss of Signal indication	3	4
9	VeeR	Receiver Ground	1	5
10	VeeR	Receiver Ground	1	5
11	VeeR	Receiver Ground	1	5
12	RD-	Receiver Inverted DATA out	3	6
13	RD+	Receiver Non-inverted DATA out	3	6
14	VeeR	Receiver Ground	1	5
15	VccR	Receiver Power Supply (3.3 ± 5%)	2	7
16	VccT	Transmitter Power Supply (3.3 ± 5%)	2	7
17	VeeT	Transmitter Ground	1	5
18	TD+	Transmitter Non-Inverted DATA in	3	8
19	TD-	Transmitter Inverted DATA in.	3	8
20	VeeT	Transmitter Ground	1	5

- Notes:**
- TX Fault is an open collector/drain output, which should be pulled up with a 4.7 K – 10 K $\Omega$  resistor on the host board. Pull up voltage between 2.0 V and VccT, R+0.3 V. When high, output indicates a laser fault of some kind. Low indicates normal operation. In the low state, the output will be pulled to < 0.8 V.
  - TX disable is an input that is used to shut down the transmitter optical output. It is pulled up within the module with a 4.7 – 10 K $\Omega$  resistor. Its states are:  
 Low (0 – 0.8V): Transmitter on  
 (>0.8, < 2.0V): Undefined  
 High (2.0 – 3.465V): Transmitter Disabled  
 Open: Transmitter Disabled
  - Modulation Absent, connected to VEET or VEER in the module.
  - LOS (Loss of Signal) is an open collector/drain output, which should be pulled up with a 4.7 K – 10 K $\Omega$  resistor. Pull up voltage between 2.0 V and VccT, R+0.3 V. When high, this output indicates the received optical power is below the worst-case receiver sensitivity (as defined by the standard in use). Low indicates normal operation. In the low state, the output will be pulled to < 0.8 V.
  - VeeR and VeeT may be internally connected within the SFP module.
  - RD-/+ : These are the differential receiver outputs. They are AC coupled 100  $\Omega$  differential lines which should be terminated with 100  $\Omega$  (differential) at the user SERDES. The AC coupling is done inside the module and is thus not required on the host board. The voltage swing on these lines will be between 400 and 2000 mV differential (200 – 1000 mV single ended) when properly terminated.
  - VccR and VccT are the receiver and transmitter power supplies. They are defined as 3.3 V  $\pm$ 5% at the SFP connector pin. Maximum supply current is 300 mA. Recommended host board power supply filtering is shown below. Inductors with DC resistance of less than 1 ohm should be used in order to maintain the required voltage at the SFP input pin with 3.3 V supply voltage. When the recommended supply-filtering network is used, hot plugging of the SFP transceiver module will result in an inrush current of no more than 30 mA greater than the steady state value. VccR and VccT may be internally connected within the SFP transceiver module.
  - TD-/+ : These are the differential transmitter inputs. They are AC-coupled, differential lines with 100  $\Omega$  differential termination inside the module. The AC coupling is done inside the module and is thus not required on the host board. The inputs will accept differential swings of 400 – 2000 mV (200 – 1000 mV single-ended).

Datasheet

Host Board Connector Pinout

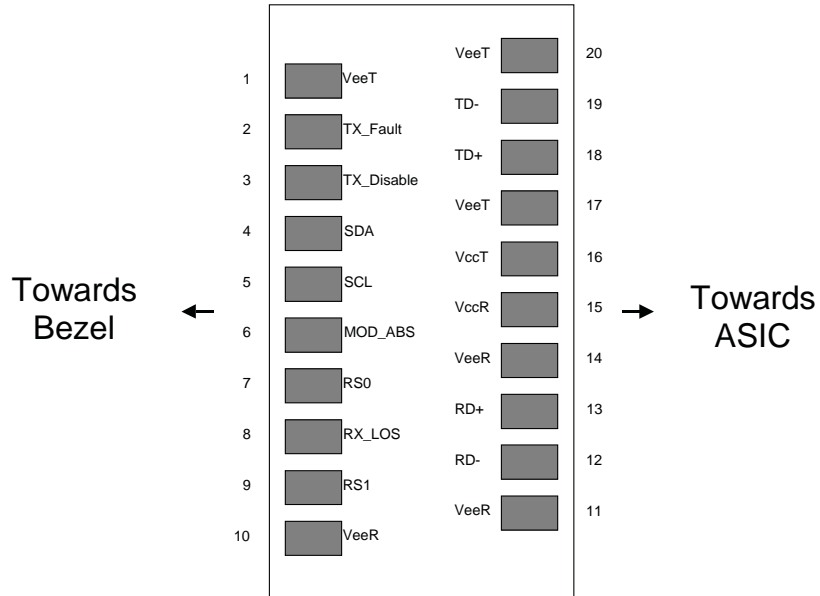

Outline Drawing

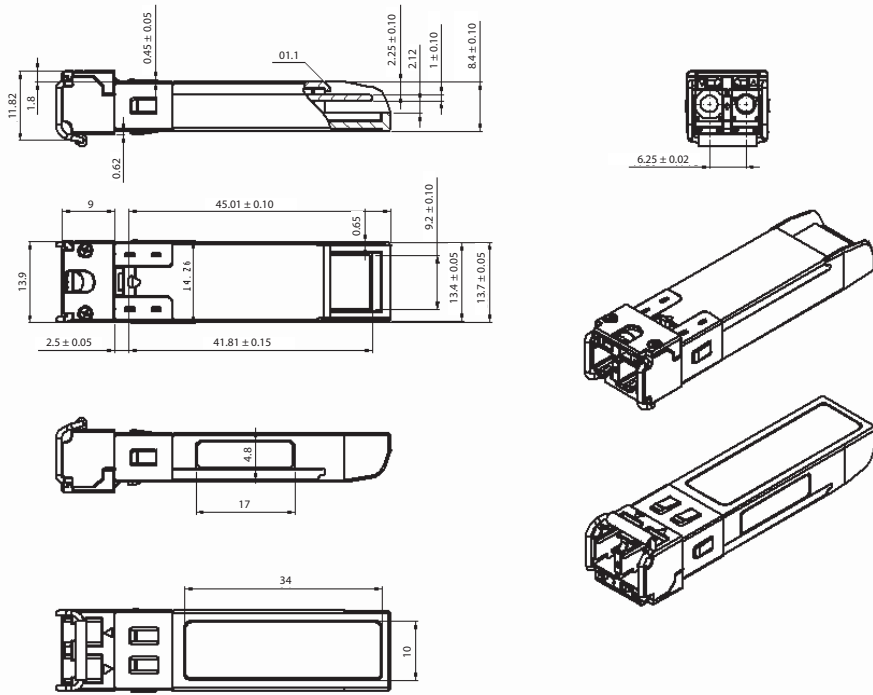

**Datasheet**

**λc Wavelength Guide**

ITU Channel/ Product Code (xx)	Frequency (THz)	Wavelength (nm)	ITU Channel/ Product Code (xx)	Frequency (THz)	Wavelength (nm)
17	191.7	1563.863	40	194.0	1545.322
18	191.8	1563.047	41	194.1	1544.526
19	191.9	1562.233	42	194.2	1543.730
20	192.0	1561.419	43	194.3	1542.936
21	192.1	1560.606	44	194.4	1542.142
22	192.2	1559.794	45	194.5	1541.349
23	192.3	1558.983	46	194.6	1540.557
24	192.4	1558.173	47	194.7	1539.766
25	192.5	1557.363	48	194.8	1538.976
26	192.6	1556.555	49	194.9	1538.186
27	192.7	1555.747	50	195.0	1537.397
28	192.8	1554.940	51	195.1	1536.609
29	192.9	1554.134	52	195.2	1535.822
30	193.0	1553.329	53	195.3	1535.036
31	193.1	1552.524	54	195.4	1534.250
32	193.2	1551.721	55	195.5	1533.465
33	193.3	1550.918	56	195.6	1532.681
34	193.4	1550.116	57	195.7	1531.898
35	193.5	1549.315	58	195.8	1531.116
36	193.6	1548.515	59	195.9	1530.334
37	193.7	1547.715	60	196.0	1529.553
38	193.8	1546.917	61	196.1	1528.773
39	193.9	1546.119			



## Datasheet

### Ordering Information

Model	Description	Data Rate (Gbps)	Digital Diagnostics	Bail Latch Color	Distance Range (km)	
					Min.	Max.
SFPFC4DW04-xx*	1/2/4 Gbps Fibre Channel and 1 Gigabit Ethernet DWDM SFP Transceiver	1.0625 - 4.25	Yes	Blue	10	40

\* See Wavelength Guide above for "xx" values

\*\* Minimum distance is dependant on the insertion loss of a Max/DeMux module used.

### Regulatory and Industry Compliances

Class 1 Laser Product, complies with EN 60825-1 and 21 CFR 1040.10 except for deviations pursuant to Laser Notice No. 50. dated June 24, 2007

MSA SFF-8074i; Digital Diagnostic SFF-8472

Certified by one or more of the following agencies: TÜV, UL, CSA

RoHS Directive; China RoHS; California RoHS Law, REACH Directive SVHC; WEEE Directive

The Quality Management System is certified to ISO 9001 by QMI-SAI Global

The Environmental Management System is in compliance with ISO 14001

### Warnings

**Handling Precautions:** This device is susceptible to damage as a result of electrostatic discharge (ESD). A static free environment is highly recommended. Follow guidelines according to proper ESD procedures.

**Laser Safety:** Radiation emitted by laser devices can be dangerous to human eyes. Avoid eye exposure to direct or indirect radiation.

MRV has more than 50 offices throughout the world. Addresses, phone numbers and fax numbers are listed at [www.mrv.com](http://www.mrv.com). Please e-mail us at [info@mrv.com](mailto:info@mrv.com) or call us for assistance.

MRV Los Angeles  
20415 Nordhoff Street  
Chatsworth, CA 91311  
800-338-5316  
818-773-0900

MRV Boston  
300 Apollo Drive  
Chelmsford, MA 01824  
800-338-5316  
978-674-6800

MRV International  
Business Park Moerfelden  
Waldeckerstrasse 13  
64546 Moerfelden-Walldorf  
Germany  
Tel. (49) 6105/2070  
Fax (49) 6105/207-100

All statements, technical information and recommendations related to the products herein are based upon information believed to be reliable or accurate. However, the accuracy or completeness thereof is not guaranteed, and no responsibility is assumed for any inaccuracies. Please contact MRV Communications for more information. MRV Communications and the MRV Communications logo are trademarks of MRV Communications, Inc. Other trademarks are the property of their respective holders.