

**Datasheet**

**4.25 Gbps Multi-Rate 80 km DWDM SFP Transceiver**

SFPFC4DW08-xx



**Highlights**

- SFP transceiver
- C-band wavelengths on the 100 GHz DWDM ITU grid
- Data Rates: 0.155 - 4.25 Gbps
- Protocols:
  - Gigabit Ethernet
  - Fibre Channel (1/2/4 Gbps)
  - Firewire (400/800)
  - SDH (STM-1/4/16)
  - SONET (OC-3/12/48)
- Single-mode fiber
- Dual fiber (Tx/Rx)
- 1550 nm
- 40 - 80 km
- Duplex LC connector
- Digital Diagnostics (SFF-8472)
- Hot-swap

**Overview**

Small Form-Factor Pluggable (SFP) interfaces from MRV Communications provide flexible high speed links in a small industry standard package. They deliver the deployment options and inventory control that network administrators demand for growing networks.

SFPs are designed to Multi-Source Agreement (MSA) standards to ensure network equipment compatibility. They are a perfect addition to MRV’s extensive lines of networking equipment.

Visit the MRV website at [www.mrv.com](http://www.mrv.com) or contact your nearest authorized MRV Communications dealer for more information.

Specifications Overview	
Data Rate	0.155 - 4.25 Gbps
Tx Wavelength	100 GHz ITU Grid, C-Band Channels 17-61
Tx Power (Minimum)	2 dBm
Tx Dispersion Penalty	3 dB
Tx Disable	Yes
Rx Wavelength	1520 - 1570 nm
Rx Sensitivity @ 2.5 Gbps	-28 dBm
Rx Sensitivity @ 4.25 Gbps	-23 dBm
Rx Saturation	-9 dBm
Rx Damage Threshold	6 dBm
Operating Temperature Range	-5 to 70 °C
Power Consumption	1 Watt

## Datasheet

### Optical Transmitter Specifications

Parameter	Symbol	Minimum	Maximum	Unit	Note
Center Wavelength Spacing	-	-	100	GHz	3
Modulated Spectral Width	$\Delta\lambda_{20}$	-	0.3	nm	4
Center Wavelength – End of Life	$\lambda_c$	X - 100	X + 100	pm	5
Center Wavelength – BOL Offset	$\lambda_c$	Y - 25	Y + 25	pm	6
Side Mode Suppression Ratio	SMSR	30	-	dB	7
Optical Rise/Fall Time	$t_r/t_f$	-	120	ps	8
Optical Output Power	$P_{out}$	2	5	dBm	9
Extinction Ratio @ 4.25G	OMI	6.0	-	dB	10
Extinction Ratio, SONET	OMI	8.2	-	dB	11
Eye Opening	-	10	-	%	-
Jitter Generation, SONET	-	-	75	mUI	2
Total Jitter (p-to-p)	-	-	59.8	ps	-
Deterministic Jitter (p-to-p)	-	-	28.2	ps	-
Reflectance	$R_{TX}$	-	-27	dB	-
Tolerable Back Reflection	BR	-	-14	dB	12
Relative Intensity Noise	RIN	-	-120	dB/Hz	-
Dispersion Power Penalty	DPP	-	3	dB	13

- Notes:**
- Parameters are specified over temperature and voltage, at end of life, and for non-rate select option unless otherwise noted.
  - Parameters per GR-253 section 5.6 for OC-48 B. All parameters are measured on a MRV SFP Evaluation Card unless otherwise noted.
  - Corresponds to approximately 0.8 nm
  - Full width, -20 dB from maximum. For accurate  $\Delta\lambda_{20}$  measurements, an OSA with a resolution band width of  $\leq 20$  pm is recommended.
  - X = specified center wavelength
  - Y = specified center wavelength
  - Modulated
  - Unfiltered, 80% -20%
  - Average power coupled into SMF-28. Output power of +3 to +7dBm is also supported; please contact your local MRV sales representatives for details.
  - End of Life (EOL)
  - EOL, rate select option only.
  - Tolerable back reflection is the maximum back reflection level at which the power penalty will be <1dB. Power penalty is measured over fiber (1600 ps/nm) at BER =  $10^{-12}$  with OSNR set at 24 dB.
  - At 1600 ps/nm. Dispersion power penalty is measured in loop back with OSNR set to 30 dB. Data rate and pattern used same as specified for Optical Input Power. Dispersion power penalty is the difference in Rx power at a BER of  $10^{-12}$  for 0 ps/nm & 1600 ps/nm.

## Datasheet

### Optical Receiver Specifications

Parameter	Symbol	Minimum	Maximum	Unit	Note
Optical Input Wavelength	$P_{in}$	1520	1570	nm	-
Jitter Generation , SONET	-	-	75	mUI	1
Total Jitter (p-to-p)	-	-	61.8	ps	-
Deterministic Jitter (p-to-p)	-	-	25.9	ps	-
Optical Input Power @ 2.5 Gbps	$P_{in}$	-28	-9	dBm	2
Optical Input Power @ 4.25 Gbps	$P_{in}$	-23	-9	dBm	3
Damage Threshold	-	-	6	dBm	-
Receiver Reflectance	$R_{RX}$	-	-27	dB	-
Dispersion Noise Penalty	DNP	-	3	dB	4

- Notes:**
- Parameters per GR-253 section 5.6 for OC-48 B. All parameters are measured on a MRV SFP Evaluation Card unless otherwise noted.
  - At  $10^{-12}$  BER, PRBS 2<sup>23</sup>-1 EOL and rate select low option implemented
  - At  $10^{-12}$  BER, PRBS 2<sup>7</sup>-1 EOL
  - At 1600 ps/nm. Dispersion noise penalty is measured in loop back with Rx power set between -9 dBm and -18 dBm. Data rate and pattern used same as specified for Optical Input Power. Dispersion noise penalty is the difference in OSNR at a BER of  $10^{-12}$  for 0 ps/nm and 1600 ps/nm.

### Absolute Maximum Ratings

Parameter	Symbol	Minimum	Maximum	Unit	Note
Maximum Supply Voltage	$V_{CC}$	-0.5	4.7	V	-
Maximum Power	$P_{MAX}$	-	1.25	W	-
Storage Temperature	$T_S$	-40	85	°C	-
Operating Case Temperature	$T_{OP}$	-5	70	°C	-

### General Operating Conditions

Parameter	Symbol	Minimum	Maximum	Unit	Note
Supply Voltage	$V_{CC}$	3.13	3.50	V	-
Supply Current (BOL)	$I_{CC}$	-	325	mA	-
Inrush Current (BOL)	$I_{surge}$	-	$I_{CC} + 30$	mA	-
Data Rate	BR	0.155	4.25	Gbps	1
Total Link Budget @ 2.5 Gbps	-	26	-	dB	2,4
Total Link Budget @ 4.25 Gbps	-	31	-	dB	3,4

- Notes:**
- SONET OC-3/12/48 compatible
  - At  $10^{-12}$  BER, PRBS 2<sup>23</sup>-1
  - At  $10^{-12}$  BER, PRBS 2<sup>7</sup>-1
  - Total link budget is defined as  $P_{out} - P_{in}$  - typical connector losses. Operating in low rate mode.

## Datasheet

### Digital Diagnostics Specifications

Parameter	Symbol	Minimum	Maximum	Unit	Note
I <sup>2</sup> C Clock Speed	-	0	100,000	Hz	-
<b>Accuracy</b>					
Transceiver Case Temperature	DD <sub>Temperature</sub>	-10	10	°C	1
Transceiver Supply Voltage	DD <sub>Voltage</sub>	-3	3	%	-
Tx Bias Current	DD <sub>Bias</sub>	-10	10	%	-
Tx Output Power	DD <sub>TxPower</sub>	-2	2	dB	-
Received Average Power	DD <sub>RxPower</sub>	-2	2	dB	-
<b>Range</b>					
Transceiver Case Temperature	DD <sub>Temperature</sub>	-40	85	°C	-
Transceiver Supply Voltage	DD <sub>Voltage</sub>	3.0	4.0	V	-
Tx Bias Current	DD <sub>Bias</sub>	0	90	mA	-
Tx Output Power	DD <sub>TxPower</sub>	-5	10	dBm	-
Received Average Power	DD <sub>RxPower</sub>	-30	-7	dBm	-

**Notes:** 1. Measured on the top-side of the module case

### Electical Transmitter Specifications

Parameter	Symbol	Min	Max	Unit	Note
Input Differential Impedence	R <sub>in</sub>	80	120	Ω	1
Single-Ended Data Input Swing	V <sub>in,p-p</sub>	250	1200	mV	-
Transmit Disable Voltage	V <sub>D</sub>	V <sub>cc</sub> - 1.3	V <sub>cc</sub>	V	-
Transmit Enable Voltage	V <sub>EN</sub>	V <sub>ee</sub>	V <sub>ee</sub> + 0.8	V	2

**Notes:** 1. Connected directly to TX data input pins. AC coupled thereafter.  
2. Or open circuit.

### Electical Receiver Specifications

Parameter	Symbol	Min	Max	Unit	Note
Single-Ended Data Output	V <sub>out,p-p</sub>	175	1000	mV	1
Data output rise time	t <sub>r</sub>	-	120	ps	2
Data output fall time	t <sub>f</sub>	-	120	ps	2
LOS Fault	V <sub>LOS fault</sub>	V <sub>cc</sub> - 0.5	V <sub>cc</sub> HOST	V	3
LOS Normal	V <sub>LOS norm</sub>	V <sub>ee</sub>	V <sub>ee</sub> + 0.5	V	3
Power Supply Rejection	PSR	100	-	mVpp	4

**Notes:** 1. Into 100 ohms differential termination.  
2. 20 – 80 %  
3. Loss of signal (LOS) is LVTTTL. Logic 0 indicates normal operation; logic 1 indicates no signal detected.  
4. Receiver sensitivity is compliant with power supply sinusoidal modulation of 20 Hz to 1.5 MHz up to specified value applied through the recommended power supply filtering network.

## Datasheet

### Timing and Electrical Specifications

Parameter	Symbol	Min	Max	Unit	Note
RX_LOS Assert Level	-	-42	-	dBm	-
RX_LOS De-assert Level	-	-	-28	dBm	-
RX_LOS Hysteresis	-	0.5	-	dB	-
RX_LOS Assert Delay	t_loss_on	-	100	µs	1
RX_LOS Negate Delay	t_loss_off	-	100	µs	2
TX_DISABLE Assert Time	t_off	-	10	µs	3
TX_DISABLE Negate Time	t_on	-	1000	µs	4
TX_DISABLE Reset Time	t_reset	10	-	µs	5
TX_FAULT Assert Time	-	-0.2	0.2	nm	6

- Notes:**
1. From detection of loss of signal to assertion of RX\_LOS.
  2. From detection of presence of signal to negation of RX\_LOS.
  3. Rising edge of TX\_DISABLE to fall of output signal below 10% of nominal.
  4. Falling edge of TX\_DISABLE to rise of output signal above 90% of nominal. Time indicated is under steady-state temperature conditions.
  5. TX\_DISABLE HIGH before TX\_DISABLE set LOW.
  6. TX\_Fault will assert before the device is outside of specified wavelength range.

### Host Board Connector Pinout

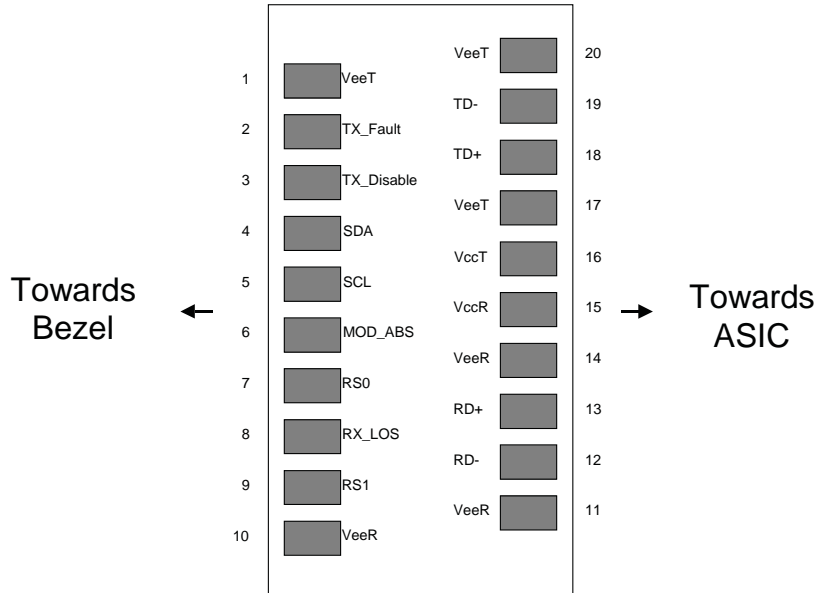

## Datasheet

Pin Descriptions			
Pin	Name	Description	Note
1	VeeT	Transmitter Ground (Common with Receiver Ground)	1
2	TX_FAULT	Transmitter Fault	-
3	TX_DISABLE	Transmitter Disable. Laser output disabled on high or open.	2
4	MOD-DEF2	Module Definition 2. Data line for Serial ID.	3
5	MOD-DEF1	Module Definition 1. Clock line for Serial ID.	3
6	MOD-DEF0	Module Definition 0. Grounded within the module.	3
7	Rate Select	No connection required.	4
8	LOS	Loss of Signal indication. Logic 0 indicates normal operation.	5
9	VeeR	Receiver Ground (Common with Transmitter Ground)	1
10	VeeR	Receiver Ground (Common with Transmitter Ground)	1
11	VeeR	Receiver Ground (Common with Transmitter Ground)	1
12	RD-	Receiver Inverted DATA out. AC Coupled.	-
13	RD+	Receiver Non-inverted DATA out. AC Coupled.	-
14	VeeR	Receiver Ground (Common with Transmitter Ground)	1
15	VccR	Receiver Power Supply	-
16	VccT	Transmitter Power Supply	-
17	VeeT	Transmitter Ground (Common with Receiver Ground)	1
18	TD+	Transmitter Non-Inverted DATA in. 100 ohm termination between TD+ and TD-, AC Coupled thereafter	-
19	TD-	Transmitter Inverted DATA in. See TD+	-
20	VeeT	Transmitter Ground (Common with Receiver Ground)	1

- Notes:**
1. Circuit ground is internally isolated from chassis ground.
  2. Laser output disabled on TDIS >2.0 V or open, enabled on TDIS <0.8 V.
  3. Should be pulled up with 4.7 k – 10 kohms on host board to a voltage between 2.0 V and 5.5 V. MOD\_DEF(0) pulls line low to indicate module is plugged in.
  4. Receiver achieves multi-rate operation without active control.
  5. LOS is open collector output. Should be pulled up with 4.7 k – 10 kohms on host board to a voltage between 2.0 V and 5.5 V. Logic 0 indicates normal operation; logic 1 indicates loss of signal.

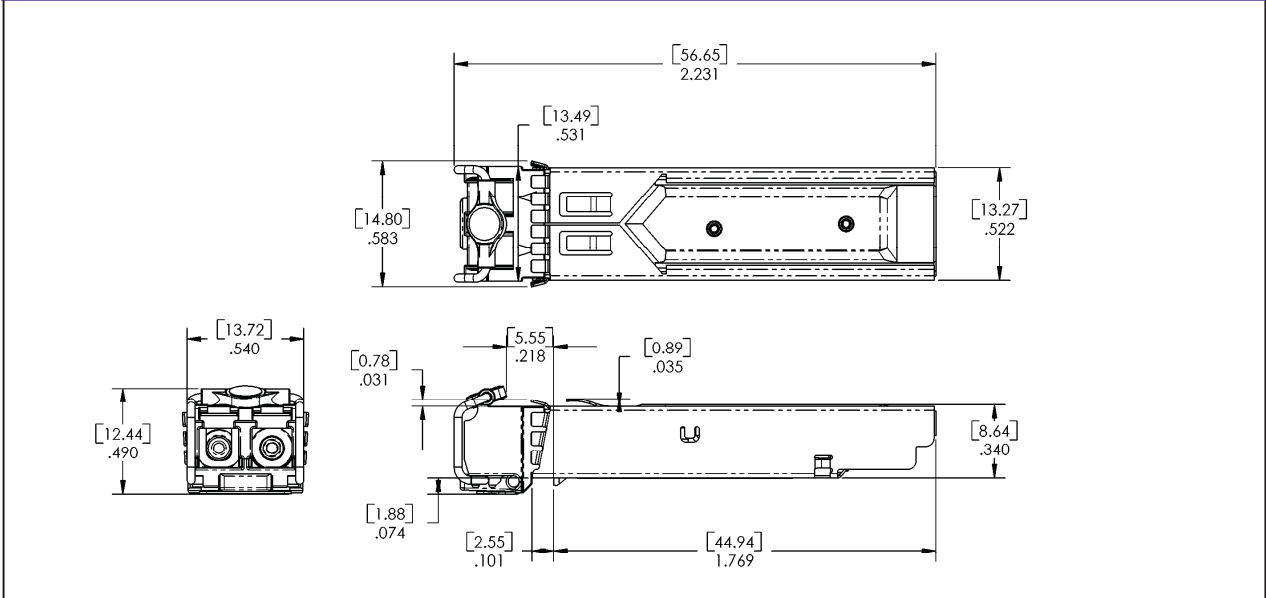
**Datasheet**
**Outline Drawing**

**λc Wavelength Guide**

ITU Channel/ Product Code	Frequency (THz)	Wavelength (nm)	ITU Channel/ Product Code	Frequency (THz)	Wavelength (nm)
17	191.7	1563.863	40	194.0	1545.322
18	191.8	1563.047	41	194.1	1544.526
19	191.9	1562.233	42	194.2	1543.730
20	192.0	1561.419	43	194.3	1542.936
21	192.1	1560.606	44	194.4	1542.142
22	192.2	1559.794	45	194.5	1541.349
23	192.3	1558.983	46	194.6	1540.557
24	192.4	1558.173	47	194.7	1539.766
25	192.5	1557.363	48	194.8	1538.976
26	192.6	1556.555	49	194.9	1538.186
27	192.7	1555.747	50	195.0	1537.397
28	192.8	1554.940	51	195.1	1536.609
29	192.9	1554.134	52	195.2	1535.822
30	193.0	1553.329	53	195.3	1535.036
31	193.1	1552.524	54	195.4	1534.250
32	193.2	1551.721	55	195.5	1533.465
33	193.3	1550.918	56	195.6	1532.681
34	193.4	1550.116	57	195.7	1531.898
35	193.5	1549.315	58	195.8	1531.116
36	193.6	1548.515	59	195.9	1530.334
37	193.7	1547.715	60	196.0	1529.553
38	193.8	1546.917	61	196.1	1528.773
39	193.9	1546.119			



## Datasheet

### Ordering Information

Model	Description	Data Rate	Digital Diagnostics	Distance Range (km)	
				Min.	Max.
SFPFC4DW08-xx*	4.25 Multi-Rate DWDM SFP Transceiver	155 Mbps to 4.25 Gbps	Yes	40	80

\* See Wavelength Guide above for "xx" values

\*\* Minimum distance is dependant on the insertion loss of a Mux/DeMux module used.

### Regulatory and Industry Compliances

Class 1 Laser Product, complies with EN 60825-1 and 21 CFR 1040.10 except for deviations pursuant to Laser Notice No. 50. dated June 24, 2007  
MSA SFF-8074i; Telcordia GR-253-CORE; Digital Diagnostic SFF-8472  
Certified by one or more of the following agencies: TÜV, UL, CSA  
RoHS Directive; China RoHS; California RoHS Law, REACH Directive SVHC; WEEE Directive  
The Quality Management System is certified to ISO 9001 by QMI-SAI Global  
The Environmental Management System is in compliance with ISO 14001

### Warnings

**Handling Precautions:** This device is susceptible to damage as a result of electrostatic discharge (ESD). A static free environment is highly recommended. Follow guidelines according to proper ESD procedures.

**Laser Safety:** Radiation emitted by laser devices can be dangerous to human eyes. Avoid eye exposure to direct or indirect radiation.

MRV has more than 50 offices throughout the world. Addresses, phone numbers and fax numbers are listed at [www.mrv.com](http://www.mrv.com).  
Please e-mail us at [info@mrv.com](mailto:info@mrv.com) or call us for assistance.

MRV Los Angeles  
20415 Nordhoff Street  
Chatsworth, CA 91311  
800-338-5316  
818-773-0900

MRV Boston  
300 Apollo Drive  
Chelmsford, MA 01824  
800-338-5316  
978-674-6800

MRV International  
Business Park Moerfelden  
Waldeckerstrasse 13  
64546 Moerfelden-Walldorf  
Germany  
Tel. (49) 6105/2070  
Fax (49) 6105/207-100

All statements, technical information and recommendations related to the products herein are based upon information believed to be reliable or accurate. However, the accuracy or completeness thereof is not guaranteed, and no responsibility is assumed for any inaccuracies. Please contact MRV Communications for more information. MRV Communications and the MRV Communications logo are trademarks of MRV Communications, Inc. Other trademarks are the property of their respective holders.