

Datasheet

100 to 155 Mbps Single Fiber Bidirectional 40 km SFP Transceivers

SFP-FD-BD35 and SFP-FD-BD53



Highlights

- SFP transceiver
- Data Rates: 100 to 155 Mbps
- Protocols:
 - Fast Ethernet
 - OC-3/STM-1
- Single-mode fiber
- Single fiber, bi-directional
- Two wavelength options:
 - Tx 1310 nm and Rx 1550 nm
 - Tx 1550 nm and Rx 1310 nm
- 16 to 40 km
- Simplex LC connector
- Digital Diagnostics (SFF-8472)
- Hot-swap
- Industrial temperature models available

Overview

Small Form-Factor Pluggable (SFP) interfaces from MRV Communications provide flexible high speed links in a small industry standard package. They deliver the deployment options and inventory control that network administrators demand for growing networks.

SFPs are designed to Multi-Source Agreement (MSA) standards to ensure network equipment compatibility. They are a perfect addition to MRV’s extensive lines of networking equipment.

Visit the MRV website at www.mrv.com or contact your nearest authorized MRV Communications dealer for more information.

Specifications Overview	
Data Rate	100 - 155 Mbps
Tx Wavelength for SFP-FD-BD35	1310 nm
Tx Wavelength for SFP-FD-BD53	1550 nm
Tx Power (Minimum)	-5 dBm
Extinction Ratio	6.6 dBm
Tx Disable	Yes
Rx Wavelength for SFP-FD-BD35	1480 to 1580 nm
Rx Wavelength for SFP-FD-BD53	1260 to 1360 nm
Rx Sensitivity	-28 dBm
Rx Saturation	-8 dBm
Operating Temperature Range	-5 to 70 °C
Operating Temperature Range (TH Models)	-40 to 85 °C
Damage Threshold	4 dBm
Power Consumption	1 Watt

Datasheet

Transmitter Specifications (Optical)

Parameter	Symbol	Min	Max	Unit	Notes
Optical Power	P_{op}	-5	0	dBm	-
Optical Crosstalk	XT	-	-40	dB	-
Average Launch Power Of Off Tx	P_{off}	-	-45	dBm	-
Extinction Ratio	ER	6.6	-	dB	-
Eye Mask	IEEE 802.3Z, SONET/SDH compliant				-
Optical Rise Time (20% to 80% values)	t_r	-	2	ns	-
Optical Fall Time (20% to 80% values)	t_f	-	2	ns	-
Mean Wavelength for SFP-FD-BD35	λ	1260	1360	nm	-
Mean Wavelength for SFP-FD-BD53	λ	1500	1600	nm	-
RMS Width (σ) for SFP-FD-BD35	σ	-	1	nm	-
RMS Width (σ) for SFP-FD-BD53	σ	-	3	nm	-
Relative Intensity Noise	RIN	-	-120	dB/Hz	-
Optical Return Loss Tolerance	ORLT	-	12	dB	-

Receiver Specifications (Optical)

Parameter	Symbol	Min	Max	Unit	Notes
Receive Power	$R_{sens,low/high}$	-28	-8	dBm	1
Damage Threshold	$P_{in,damage}$	4	-	dBm	-
Wavelength for SFP-FD-BD35	λ	1480	1580	nm	-
Wavelength for SFP-FD-BD53	λ	1260	1360	nm	-
LOS Assert	-	-45	-	dBm	-
LOS De-assert	-	-	-28	dBm	-
LOS Hysteresis	-	0.5	-	dB	-

Notes: 1. Measured at 10^{-12} BER, PRBS 27-1

Digital Diagnostics

Parameter	Range	Accuracy	Unit	Calibration	Bit Value	Formula
Temperature	-5 to 70	± 3	$^{\circ}C$	Internal	1/256 C	$T_c(C) = T_{ad}(16 \text{ bit signed twos complement})/256$
Temperature (TH Models)	-40 to 85	± 3	$^{\circ}C$	Internal	1/256 C	$T_c(C) = T_{ad}(16 \text{ bit signed twos complement})/256$
Voltage	0 to V_{cc}	± 0.1	V	Internal	100 μ V	$V(\text{Volts}) = V_{ad}(16 \text{ bit unsigned integer}) * 0.1$
Bias Current	0 to 120	± 5	mA	External	-	$I(\text{mA}) = I_{slope} * I_{ad}(16 \text{ bit unsigned integer}) + I_{offset}$
TX Power	-5 to 0	± 3	dBm	External	-	$TX_PWR(\mu W) = TX_PWR_{slope} * TX_PWR_{ad}(16 \text{ bit unsigned integer}) + TX_PWR_{offset}$
RX Power	-28 to -8	± 3	dBm	External	-	$RX_PWR(\mu W) = A_0 + A_1 * x + A_2 * x^2 + A_3 * x^3 + A_4 * x^4$

Datasheet

General Operations

Parameter	Symbol	Min	Max	Unit	Notes
Supply Voltage	V_{CC}	3.135	3.465	V	-
Total Current	I_{CC}	-	300	mA	-
Power Supply Noise Rejection	PSR	100	-	mV _{p-p}	-
Operating Temperature of SFP Case	T_{opr}	-5	70	°C	1
Operating Temperature (TH Models)	T_{opr}	-40	85	°C	1
Storage Temperature	T_{stg}	-40	85	°C	-
Data Rate	DR	100	155	Mbps	-

Notes: 1. Maximum Relative Humidity is 85%, non-condensing

Transmitter Specifications (Electrical)

Parameter	Symbol	Min	Max	Unit	Notes
Input Differential Impedance	R_{in}	80	120	Ω	-
PECL Single Ended Data Input Swing	$V_{in,p-p}$	250	1200	mV	-
TxFault_Fault	V_{fault}	2	V_{CC}	V	-
TxFault_Normal	V_{normal}	V_{EE}	$V_{EE}+0.5$	V	-
TxDisable_Disable	V_d	2	V_{CC}	V	-
TxDisable_Enable	V_{en}	V_{EE}	$V_{EE}+0.8$	V	-

Receiver Specifications (Electrical)

Parameter	Symbol	Min	Max	Unit	Notes
PECL Single Ended Data Output Swing	$V_{out,p-p}$	185	800	mV	-
Data Output Rise Time	t_r	-	2	ns	-
Data Output Fall Time	t_f	-	2	ns	-

Electrical Specifications and Timing

Parameter	Symbol	Min	Max	Unit	Notes
Tx Disable Negate Time	t_{on}	-	25	ms	-
Tx Disable Assert Time	t_{off}	-	10	μ s	-
Time to Initialize, Including Reset of Tx Fault	t_{init}	-	300	ms	-
Tx Fault Assert Time	t_{fault}	-	100	μ s	-
Tx Disable To Reset	t_{reset}	10	-	μ s	-
LOS Assert Time	$t_{loss_{on}}$	-	300	μ s	-
LOS De-assert Time	$t_{loss_{off}}$	-	100	μ s	-
Serial ID Clock Rate	f_{serial_clock}	-	100	KHz	-
RX_LOS Voltage (High)	RX_LOS_H	2	-	V	-
RX_LOS Voltage (Low)	RX_LOS_L	-	0.8	V	-
LOS Output Voltage-Fault	$V_{LOS\ fault}$	2	V_{CC}	V	-
LOS Output Voltage-Normal	$V_{LOS\ normal}$	V_{EE}	$V_{EE}+0.5$	V	-
MOD_DEF (0:2)-High	V_H	2	V_{CC}	V	-
MOD_DEF (0:2)-Low	V_L	V_{EE}	$V_{EE}+0.5$	V	-

Datasheet

Pin	Function	Name / Description	Notes
1	V _{ee} T	Module Transmitter Ground	-
2	TX_FAULT	Open Collector	-
3	TX_DISABLE	Internally Pulled High	-
4	MOD_DEF2	Serial Data Input	-
5	MOD_DEF1	Serial Clock Input	-
6	MOD_DEF0	Internally Grounded	-
7	NC	Not Connected	-
8	LOS	Open Collector	-
9	V _{ee} R	Module Receiver Ground	-
10	V _{ee} R	Module Receiver Ground	-
11	V _{ee} R	Module Receiver Ground	-
12	RXD-	Receiver Data Negative	-
13	RXD+	Receiver Data Positive	-
14	V _{ee} R	Module Receiver Ground	-
15	V _{cc} R	Module Receiver Power Supply	-
16	V _{cc} T	Module Transmitter Power Supply	-
17	V _{ee} T	Module Transmitter Ground	-
18	TXD+	Transmitter Data Positive	-
19	TXD-	Transmitter Data Negative	-
20	V _{ee} T	Module Transmitter Ground	-

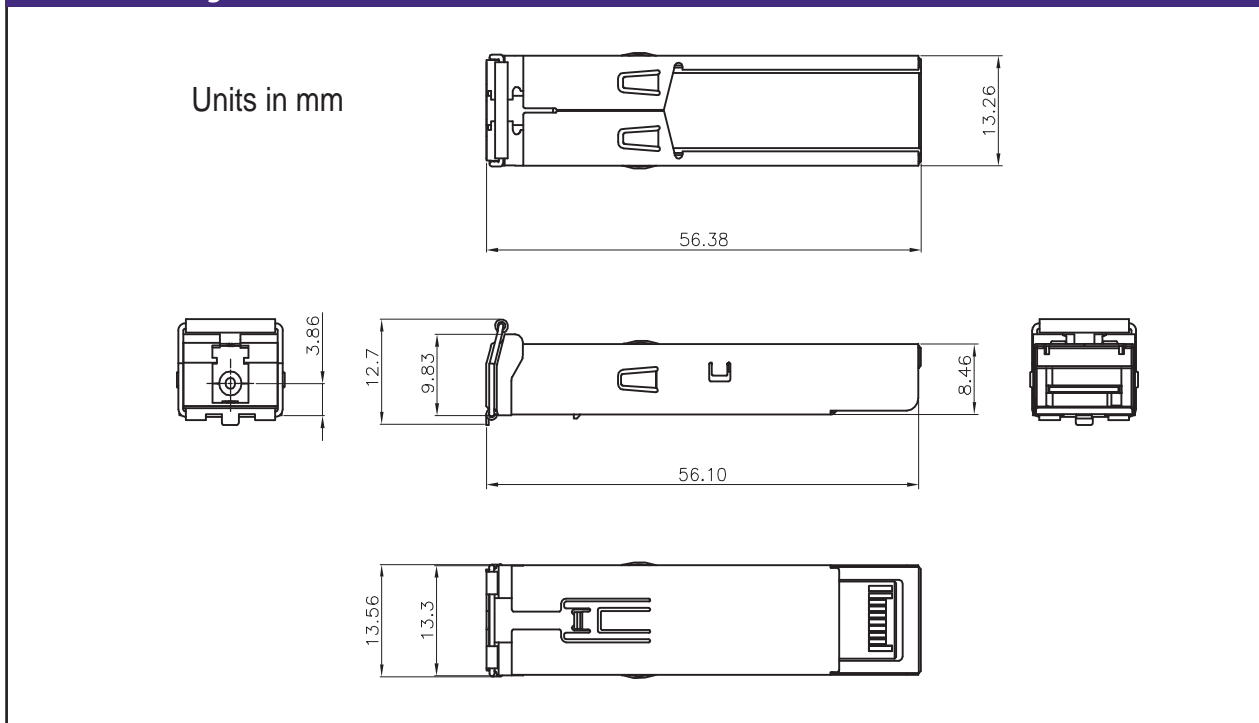
Outline Drawing



Datasheet

Ordering Information

Model	Description	Data Rate (Mbps)	Wavelength (nm)		Connector Type	Digital Diagnostics	Bail Latch Color	Distance Range (km)
			Tx	Rx				
SFP-FD-BD35	SFP Bidirectional Transceiver	100 - 155	1310	1490	LC	Yes	Blue	16 - 40
SFP-FD-BD53	SFP Bidirectional Transceiver	100 - 155	1490	1310	LC	Yes	Yellow	16 - 40
SFP-FD-BD35TH	SFP Bidirectional Transceiver (Temperature Hardened)	100 - 155	1310	1490	LC	Yes	Blue	16 - 40
SFP-FD-BD53TH	SFP Bidirectional Transceiver (Temperature Hardened)	100 - 155	1490	1310	LC	Yes	Yellow	16 - 40

Regulatory and Industry Compliances

Class 1 Laser Product, complies with EN 60825-1 and 21 CFR 1040.10 except for deviations pursuant to Laser Notice No. 50, dated June 24, 2007
MSA SFF-8074i; Telcordia GR-468, Digital Diagnostic SFF-8472;

Certified by one or more of the following agencies: TÜV, UL, CSA

RoHS Directive; China RoHS; California RoHS Law, REACH Directive SVHC; WEEE Directive

The Quality Management System is certified to ISO 9001 by QMI-SAI Global

The Environmental Management System is in compliance with ISO 14001

Warnings

Handling Precautions: This device is susceptible to damage as a result of electrostatic discharge (ESD). A static free environment is highly recommended. Follow guidelines according to proper ESD procedures.

Laser Safety: Radiation emitted by laser devices can be dangerous to human eyes. Avoid eye exposure to direct or indirect radiation.

MRV has more than 50 offices throughout the world. Addresses, phone numbers and fax numbers are listed at www.mrv.com.
Please e-mail us at info@mrv.com or call us for assistance.

MRV Los Angeles
20415 Nordhoff Street
Chatsworth, CA 91311
800-338-5316
818-773-0900

MRV Boston
300 Apollo Drive
Chelmsford, MA 01824
800-338-5316
978-674-6800

MRV International
Business Park Moerfelden
Waldeckerstrasse 13
64546 Moerfelden-Walldorf
Germany
Tel. (49) 6105/2070
Fax (49) 6105/207-100

All statements, technical information, and recommendations related to the products herein are based upon information believed to be reliable or accurate. However, the accuracy or completeness thereof is not guaranteed, and no responsibility is assumed for any inaccuracies. Please contact MRV Communications for more information. MRV Communications and the MRV Communications logo are trademarks of MRV Communications, Inc. Other trademarks are the property of their respective holders.