

## Datasheet

# 1.25 Gbps Single Fiber Bidirectional 96 km SFP Transceivers

SFP-GD-BZ45 and SFP-GD-BZ54



### Highlights

- SFP transceiver
- Data Rates: 1250 Mbps
- Protocols:
  - Gigabit Ethernet
- Single-mode fiber
- Single fiber, bi-directional
- Two wavelength options:
  - Tx 1490 nm and Rx 1570 nm
  - Tx 1570 nm and Rx 1490 nm
- 32 to 96 km
- Simplex LC connector
- Digital Diagnostics (SFF-8472)
- Hot-swap

### Overview

Small Form-Factor Pluggable (SFP) interfaces from MRV Communications provide flexible high speed links in a small industry standard package. They deliver the deployment options and inventory control that network administrators demand for growing networks.

SFPs are designed to Multi-Source Agreement (MSA) standards to ensure network equipment compatibility. They are a perfect addition to MRV's extensive lines of networking equipment.

Visit the MRV website at [www.mrv.com](http://www.mrv.com) or contact your nearest authorized MRV Communications dealer for more information.

### Specifications Overview

Data Rate	1250 Mbps
Tx Wavelength for <b>SFP-GD-BZ45</b>	1490 nm
Tx Wavelength for <b>SFP-GD-BZ54</b>	1570 nm
Tx Power (Minimum)	0 dBm
Tx Extinction Ratio	9 dBm
Tx Disable	Yes
Rx Wavelength for <b>SFP-GD-BZ45</b>	1550 to 1590 nm
Rx Wavelength for <b>SFP-GD-BZ54</b>	1470 to 1510 nm
Rx Sensitivity	-24 dBm
Rx Saturation	-3 dBm
Rx Damage Threshold	0 dBm
Operating Temperature Range	-5 to 70 °C
Power Consumption	1 Watt

## Datasheet

### Transmitter Specifications (Optical)

Parameter	Symbol	Min	Max	Unit	Notes
Optical Power	$P_{op}$	0	5	dBm	-
Optical Crosstalk	XT	-	-40	dB	-
Average Launch Power of Off Tx	$P_{off}$	-	-45	dBm	-
Extinction Ratio	ER	9	-	dB	-
Eye Mask	-	IEEE 802.3ah compliant			-
Optical Rise Time (20% to 80% values)	$t_r$	-	260	ps	-
Optical Fall Time (20% to 80% values)	$t_f$	-	260	ps	-
Mean Wavelength for SFP-GD-BZ45	$\lambda$	1470	1510	nm	-
Mean Wavelength for SFP-GD-BZ54	$\lambda$	1550	1590	nm	-
RMS Width	$\Delta\lambda$	-	1	nm	-
Relative Intensity Noise	RIN	-	-120	dB/Hz	-
Transmitter Reflectance	-	-	-12	dB	-
Optical Return Loss Tolerance	ORLT	-	12	dB	-

### Receiver Specifications (Optical)

Parameter	Symbol	Min	Max	Unit	Notes
Receive Power	$R_{sens,low/high}$	-24	-3	dBm	1
Damage Threshold	$P_{in,damage}$	0	-	dBm	-
Wavelength for SFP-GD-BZ45	$\lambda$	1550	1590	nm	-
Wavelength for SFP-GD-BZ54	$\lambda$	1470	1510	nm	-
LOS Assert	-	-45	-	dBm	-
LOS De-assert	-	-	-24	dBm	-
LOS Hysteresis	-	0.5	-	dB	-
Receiver Reflectance	-	-	-12	dB	-

**Notes:** 1. Measured at  $10^{-12}$  BER, PRBS 2<sup>7</sup>-1, 9 dB ER

### Digital Diagnostics

Parameter	Range	Accuracy	Unit	Calibration	Bit Value	Formula
Temperature	-5 to 70	$\pm 3$	°C	Internal	1/256 C	$T_c(C) = T_{ad}(16 \text{ bit signed twos complement})/256$
Voltage	0 to $V_{CC}$	$\pm 0.1$	V	Internal	100 $\mu$ V	$V(\text{Volts}) = V_{ad}(16 \text{ bit unsigned integer}) * 0.1$
Bias Current	0 to 120	$\pm 5$	mA	External	-	$I(\text{mA}) = I_{slope} * I_{ad}(16 \text{ bit unsigned integer}) + I_{offset}$
TX Power	0 to 3.5	$\pm 3$	dBm	External	-	$TX\_PWR(\mu W) = TX\_PWR_{slope} * TX\_PWR_{ad}(16 \text{ bit unsigned integer}) + TX\_PWR_{offset}$
RX Power	-24 to -3	$\pm 3$	dBm	External	-	$RX\_PWR(\mu W) = A_0 + A_1 * x + A_2 * x^2 + A_3 * x^3 + A_4 * x^4$

## Datasheet

### General Operations

Parameter	Symbol	Min	Max	Unit	Notes
Supply Voltage	$V_{CC}$	3.135	3.465	V	-
Total Current	$I_{CC}$	-	300	mA	-
Power Supply Noise Rejection	PSR	100	-	mV <sub>p-p</sub>	-
Operating Temperature of SFP Case	$T_{opr}$	-5	70	°C	1
Storage Temperature	$T_{stg}$	-40	85	°C	-
Data Rate	DR	-	1250	Mbps	-

**Notes:** 1. Maximum Relative Humidity is 85%, non-condensing

### Transmitter Specifications (Electrical)

Parameter	Symbol	Min	Max	Unit	Notes
Input Differential Impedance	$R_{in}$	80	120	$\Omega$	-
PECL Single Ended Data Input Swing	$V_{in,p-p}$	250	1200	mV	-
TxFault_Fault	$V_{fault}$	2	$V_{CC}$	V	-
TxFault_Normal	$V_{normal}$	$V_{EE}$	$V_{EE}+0.5$	V	-
TxDisable_Disable	$V_d$	2	$V_{CC}$	V	-
TxDisable_Enable	$V_{en}$	$V_{EE}$	$V_{EE}+0.8$	V	-

### Receiver Specifications (Electrical)

Parameter	Symbol	Min	Max	Unit	Notes
PECL Single Ended Data Output Swing	$V_{out,p-p}$	185	800	mV	-
Data Output Rise Time	$t_r$	-	175	ps	-
Data Output Fall Time	$t_f$	-	175	ps	-

### Electrical Specifications and Timing

Parameter	Symbol	Min	Max	Unit	Notes
Tx Disable Negate Time	$t_{on}$	-	1	ms	-
Tx Disable Assert Time	$t_{off}$	-	10	$\mu$ s	-
Time to Initialize, Including Reset of Tx Fault	$t_{init}$	-	300	ms	-
Tx Fault Assert Time	$t_{fault}$	-	100	$\mu$ s	-
Tx Disable To Reset	$t_{reset}$	10	-	$\mu$ s	-
LOS Assert Time	$t_{loss_{on}}$	-	100	$\mu$ s	-
LOS De-assert Time	$t_{loss_{off}}$	-	100	$\mu$ s	-
Serial ID Clock Rate	$f_{serial\_clock}$	-	100	KHz	-
RX_LOS Voltage (High)	$RX\_LOS_H$	2	$V_{CC}$	V	-
RX_LOS Voltage (Low)	$RX\_LOS_L$	-	0.8	V	-
LOS Output Voltage-Fault	$V_{LOS\ fault}$	2	$V_{CC}$	V	-
LOS Output Voltage-Normal	$V_{LOS\ normal}$	$V_{EE}$	$V_{EE}+0.5$	V	-
MOD_DEF (0:2)-High	$V_H$	2	$V_{CC}$	V	-
MOD_DEF (0:2)-Low	$V_L$	$V_{EE}$	$V_{EE}+0.5$	V	-

**Datasheet**

Pin	Function	Name / Description	Notes
1	V <sub>ee</sub> T	Module Transmitter Ground	-
2	TX_FAULT	Open Collector	-
3	TX_DISABLE	Internally Pulled High	-
4	MOD_DEF2	Serial Data Input	-
5	MOD_DEF1	Serial Clock Input	-
6	MOD_DEF0	Internally Grounded	-
7	NC	Not Connected	-
8	LOS	Open Collector	-
9	V <sub>ee</sub> R	Module Receiver Ground	-
10	V <sub>ee</sub> R	Module Receiver Ground	-
11	V <sub>ee</sub> R	Module Receiver Ground	-
12	RXD-	Receiver Data Negative	-
13	RXD+	Receiver Data Positive	-
14	V <sub>ee</sub> R	Module Receiver Ground	-
15	V <sub>cc</sub> R	Module Receiver Power Supply	-
16	V <sub>cc</sub> T	Module Transmitter Power Supply	-
17	V <sub>ee</sub> T	Module Transmitter Ground	-
18	TXD+	Transmitter Data Positive	-
19	TXD-	Transmitter Data Negative	-
20	V <sub>ee</sub> T	Module Transmitter Ground	-

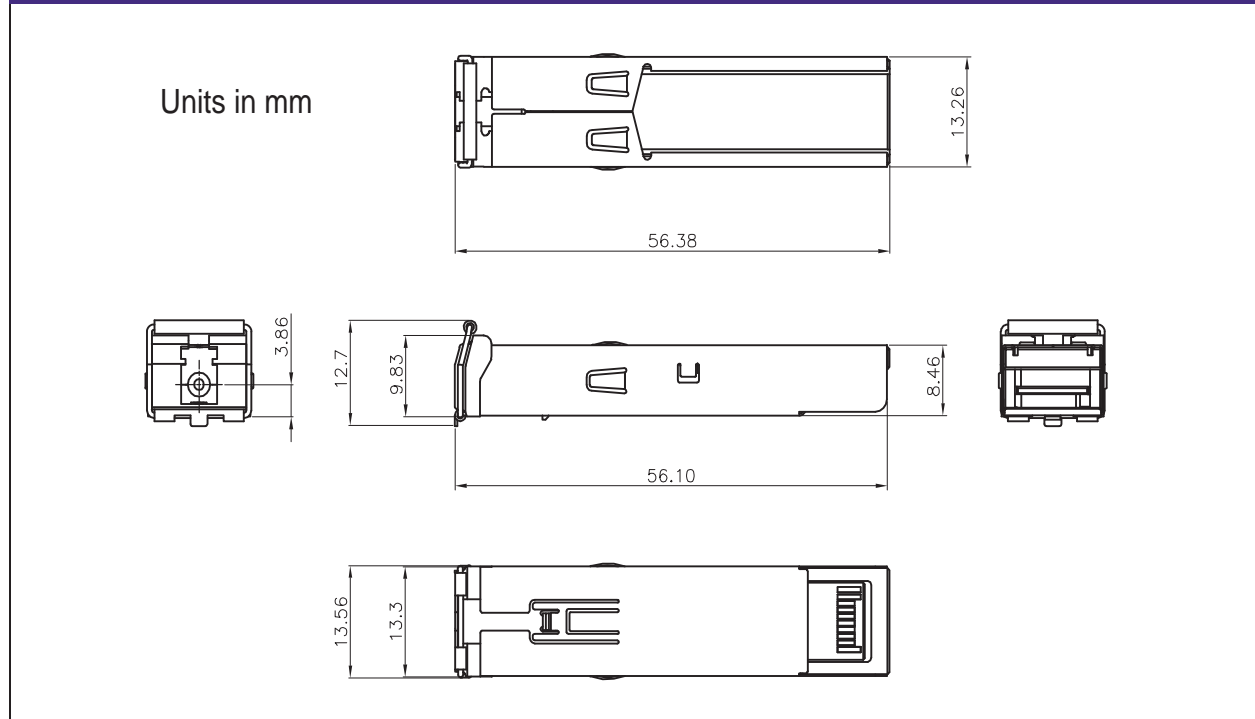
**Outline Drawing**



## Datasheet

### Ordering Information

Model	Description	Data Rate (Mbps)	Wavelength (nm)		Connector Type	Digital Diagnostics	Ball Latch Color	Distance Range (km)
			Tx	Rx				
<b>SFP-GD-BZ45</b>	SFP Bidirectional Transceiver	1250	1490	1570	LC	Yes	Purple	32 - 96
<b>SFP-GD-BZ54</b>	SFP Bidirectional Transceiver	1250	1570	1490	LC	Yes	Orange	32 - 96

### Regulatory and Industry Compliances

Class 1 Laser Product, complies with EN 60825-1 and 21 CFR 1040.10 except for deviations pursuant to Laser Notice No. 50. dated June 24, 2007  
MSA SFF-8074i; Telcordia GR-468, Digital Diagnostic SFF-8472;  
Certified by one or more of the following agencies: TÜV, UL, CSA  
RoHS Directive; China RoHS; California RoHS Law, REACH Directive SVHC; WEEE Directive  
The Quality Management System is certified to ISO 9001 by QMI-SAI Global  
The Environmental Management System is in compliance with ISO 14001

### Warnings

**Handling Precautions:** This device is susceptible to damage as a result of electrostatic discharge (ESD). A static free environment is highly recommended. Follow guidelines according to proper ESD procedures.

**Laser Safety:** Radiation emitted by laser devices can be dangerous to human eyes. Avoid eye exposure to direct or indirect radiation.

MRV has more than 50 offices throughout the world. Addresses, phone numbers and fax numbers are listed at [www.mrv.com](http://www.mrv.com).  
Please e-mail us at [info@mrv.com](mailto:info@mrv.com) or call us for assistance.

MRV Los Angeles  
20415 Nordhoff Street  
Chatsworth, CA 91311  
800-338-5316  
818-773-0900

MRV Boston  
300 Apollo Drive  
Chelmsford, MA 01824  
800-338-5316  
978-674-6800

MRV International  
Business Park Moerfelden  
Waldeckerstrasse 13  
64546 Moerfelden-Walldorf  
Germany  
Tel. (49) 6105/2070  
Fax (49) 6105/207-100

All statements, technical information, and recommendations related to the products herein are based upon information believed to be reliable or accurate. However, the accuracy or completeness thereof is not guaranteed, and no responsibility is assumed for any inaccuracies. Please contact MRV Communications for more information. MRV Communications and the MRV Communications logo are trademarks of MRV Communications, Inc. Other trademarks are the property of their respective holders.