

Datasheet

1.0625/1.25 Gbps Single-Mode 20 km SFP Transceiver

SFP-GD-LX



Highlights

- SFP transceiver
- Line Rates: 1.0625 and 1.25 Gbps
- Protocols:
 - 1 Gigabit Ethernet (1.25 Gbps)
 - 1 Gbps Fibre Channel (1.0625 Gbps)
- Single-mode fiber
- 1310 nm
- 0 to 20 km
- Duplex LC connector
- Digital Diagnostics (SFF-8472)
- Hot-swap

Overview

Small Form-Factor Pluggable (SFP) interfaces from MRV Communications provide flexible high speed links in a small industry standard package. They deliver the deployment options and inventory control that network administrators demand for growing networks.

SFPs are designed to Multi-Source Agreement (MSA) standards to ensure network equipment compatibility. They are a perfect addition to MRV's extensive lines of networking equipment.

Visit the MRV website at www.mrv.com or contact your nearest authorized MRV Communications dealer for more information.

Specifications Overview

Line Rate	1.0625 and 1.25 Gbps
Tx Wavelength	1310 nm
Tx Power (Minimum)	-9.5 dBm
Tx Disable	Yes
Rx Wavelength	1260 - 1580 nm
Rx Sensitivity	-20 dBm
Rx Saturation	-3 dBm
Operating Temperature Range	-5 to 70 °C
Power Consumption	1 Watt

Datasheet

Optical Specifications

Parameter	Symbol	Minimum	Maximum	Unit	Note
Transmitter					
Centre Wavelength	λ_C	1270	1355	nm	-
Average Output Power	P_{OUT}	-9.5	-3	dBm	1
P_{OUT} @ TX Disable Asserted	P_{OUT}	-	-45	dBm	1
Spectral Width (RMS)	σ	-	4	nm	-
Extinction Ratio	EX	9	-	dB	-
Optical Rise/Fall Time (20% ~ 80%)	t_r, t_f	-	0.26	ns	2
Total Jitter @ 1250 Mbps	T_J	-	0.431	UI	3
Total Jitter @ 1062 Mbps	T_J	-	0.43	UI	3
Deterministic Jitter @ 1250 Mbps	D_J	-	0.2	UI	3
Deterministic Jitter @ 1062 Mbps	D_J	-	0.21	UI	3
Output Optical Eye	-	IEEE 802.3ah and ANSI Fibre Channel Compliant			4
Receiver					
Centre Wavelength	λ_C	1260	1580	nm	-
Receiver Sensitivity	-	-	-20	dBm	5
Receiver Overload	-	-3	-	dBm	5
Return Loss	-	12	-	dB	-
LOS De-Assert	LOS_D	-	-21	dBm	-
LOS Assert	LOS_A	-35	-	dBm	-
LOS Hysteresis	-	1	4	dB	-
Total Jitter @ 1250 Mbps	T_J	-	0.749	UI	3
Total Jitter @ 1062 Mbps	T_J	-	0.61	UI	3
Deterministic Jitter @ 1250 Mbps	D_J	-	0.462	UI	3
Deterministic Jitter @ 1062 Mbps	D_J	-	0.36	UI	3

- Notes:**
1. The optical power is launched into SMF.
 2. Unfiltered, measured with a PRBS 2⁷-1 test pattern @ 1.25Gbps
 3. Meet the specified maximum output jitter requirements if the specified maximum input jitter is present.
 4. Measured with a PRBS 2⁷-1 test pattern @ 1.25 Gbps/1.0625 Gbps.
 5. Measured with a PRBS 2⁷-1 test pattern @ 1.25 Gbps, worst-case extinction ratio, BER ~1 x10⁻¹².

Digital Diagnostics Monitoring Specifications

Parameter	Minimum	Maximum	Unit	Accuracy	Calibration	Note
Temperature	-10	80	°C	±3 °C	Internal	-
Voltage	3.0	3.6	V	±3 %	Internal	-
Bias Current	0	100	mA	±10 %	Internal	-
TX Power	-11	-2	dBm	3 dB	Internal	-
RX Power	-21	-2	dBm	3 dB	Internal	-

Datasheet

Recommended Operating Conditions

Parameter	Symbol	Minimum	Maximum	Unit	Note
Operating Case Temperature	T_C	-5	70	°C	-
Power Supply Voltage	V_{CC}	3.13	3.47	V	-
Power Supply Current	I_{CC}	-	300	mA	-
Power Dissipation	P_D	-	1	W	-
Data Rate	DR	1062	1250	Mbps	-

Absolute Maximum Ratings

Parameter	Symbol	Minimum	Maximum	Unit	Note
Storage Temperature	T_S	-40	85	°C	-
Supply Voltage	V_{CC}	-0.5	3.6	V	-
Operating Relative Humidity	RH	5	95	%	-

Electrical Specifications

Parameter	Symbol	Minimum	Maximum	Unit	Note
Transmitter					
Data Input Swing Differential	V_{IN}	500	2400	mV	1
Input Differential Impedance	Z_{IN}	90	110	Ω	-
Tx_DIS Disable	V_D	2.0	V_{CC}	V	-
Tx_DIS Enable	V_{EN}	GND	$GND - 0.8$	V	-
Tx_Fault (Fault)	-	2.0	$V_{CC} - 0.3$	V	-
Tx_Fault (Normal)	-	0	0.8	V	-
Receiver					
Data Output Swing Differential	V_{out}	370	2000	mV	1
LOS Fault	$V_{LOS\ fault}$	2.0	$V_{CC} - 0.3$	V	-
LOS Normal	$V_{LOS\ norm}$	GND	$GND - 0.8$	V	-

Notes: 1. AC coupled.

Diagram of Host Board Connector Block Pin Numbers and Names

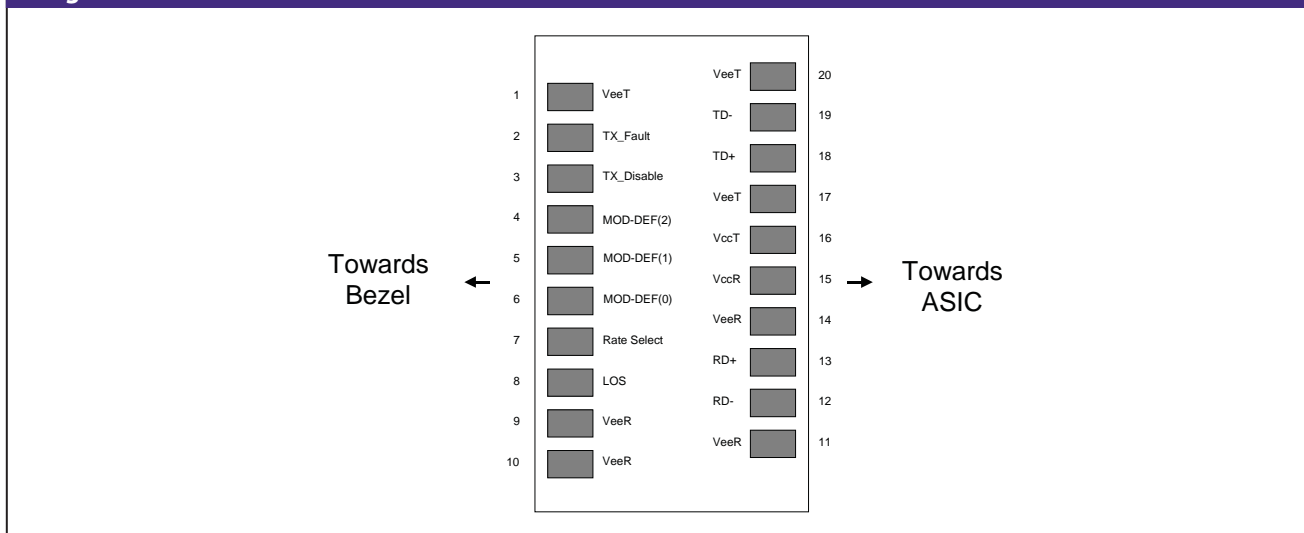

Datasheet

Pin Descriptions				
Pin	Name	Name/Description	Plug Seq.	Note
1	VeeT	Transmitter Ground	1	-
2	Tx Fault	Transmitter Fault Indication	3	1
3	Tx Disable	Transmitter Disable	3	2
4	MOD-DEF2	Module Definition 2	3	3
5	MOD-DEF1	Module Definition 1	3	3
6	MOD-DEF0	Module Definition 0	3	3
7	Rate Select	Not Connected	3	-
8	LOS	Loss of Signal	3	4
9	VeeR	Receiver Ground	1	-
10	VeeR	Receiver Ground	1	-
11	VeeR	Receiver Ground	1	-
12	RD-	Inverted Received Data Out	3	5
13	RD+	Received Data Out	3	5
14	VeeR	Receiver Ground	1	-
15	VccR	Receiver Power	2	-
16	VccT	Transmitter Power	2	-
17	VeeT	Transmitter Ground	1	-
18	TD+	Transmitter Data In	3	6
19	TD-	Inverted Transmitter Data In	3	6
20	VeeT	Transmitter Ground	1	-

- Notes:**
- TX Fault is an open collector output, which should be pulled up with a 4.7 k ~ 10 kΩ resistor on the host board to a voltage between 2.0V and Vcc+0.3V. Logic 0 indicates normal operation; logic 1 indicates a laser fault of some kind. In the low state, the output will be pulled to less than 0.8 V.
 - TX Disable is an input that is used to shut down the transmitter optical output. It is pulled up within the module with a 4.7 k ~ 10 kΩ resistor. Its states are:
 Low (0~0.8V): Transmitter on
 (>0.8V, <2.0V): Undefined
 High (2.0~3.465V): Transmitter Disabled
 Open: Transmitter Disabled
 - MOD-DEF 0,1,2 are the module definition pins. They should be pulled up with a 4.7 k ~ 10 kΩ resistor on the host board. The pull-up voltage shall be VccT or VccR.
 MOD-DEF 0 is grounded by the module to indicate that the module is present
 MOD-DEF 1 is the clock line of two wires serial interface for serial ID
 MOD-DEF 2 is the data line of two wires serial interface for serial ID
 - LOS is an open collector output, which should be pulled up with a 4.7 k ~ 10 kΩ resistor on the host board to a voltage between 2.0 V and Vcc+0.3 V. Logic 0 indicates normal operation; logic 1 indicates loss of signal. In the low state, the output will be pulled to less than 0.8 V.
 - These are the differential receiver output. They are internally AC-coupled 100Ω differential lines which should be terminated with 100Ω (differential) at the user SERDES.
 - These are the differential transmitter inputs. They are AC-coupled, differential lines with 100Ω differential termination inside the module.

Datasheet

Mechanical Dimensions

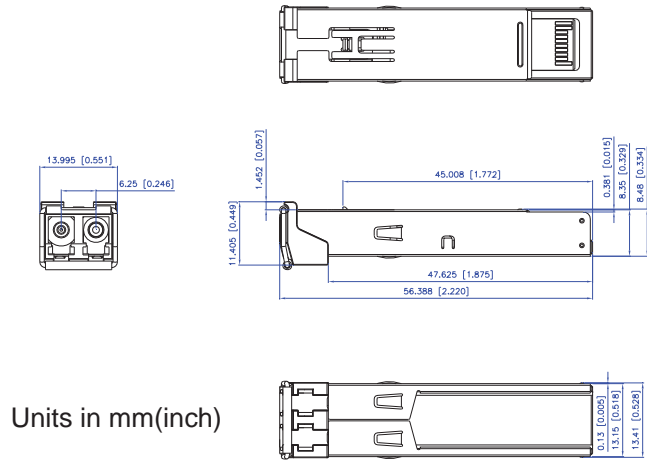

Ordering Information

Model	Description	Data Rate (Gbps)	Wavelength (nm)	Connector	Digital Diagnostics	Bail Latch Color	Maximum Distance Range (km)
SFP-GD-LX	1.0625/1.25 Gbps Single-Mode SFP Transceiver	1.0625/1.25	1310	Duplex LC	Yes	Blue	0 -20

Regulatory and Industry Compliances

Class 1 Laser Product, complies with EN 60825-1 and 21 CFR 1040.10 except for deviations pursuant to Laser Notice No. 50. dated June 24, 2007
 MSA SFF-8074i; Digital Diagnostic SFF-8472;
 Certified by one or more of the following agencies: TÜV, UL, CSA
 RoHS Directive; China RoHS; California RoHS Law, REACH Directive SVHC; WEEE Directive
 The Quality Management System is certified to ISO 9001 by QMI-SAI Global
 The Environmental Management System is in compliance with ISO 14001

Warnings

Handling Precautions: This device is susceptible to damage as a result of electrostatic discharge (ESD). A static free environment is highly recommended. Follow guidelines according to proper ESD procedures.

Laser Safety: Radiation emitted by laser devices can be dangerous to human eyes. Avoid eye exposure to direct or indirect radiation.

MRV has more than 50 offices throughout the world. Addresses, phone numbers and fax numbers are listed at www.mrv.com. Please e-mail us at info@mrv.com or call us for assistance.

MRV Los Angeles
 20415 Nordhoff Street
 Chatsworth, CA 91311
 800-338-5316
 818-773-0900

MRV Boston
 300 Apollo Drive
 Chelmsford, MA 01824
 800-338-5316
 978-674-6800

MRV International
 Business Park Moerfelden
 Waldeckerstrasse 13
 64546 Moerfelden-Walldorf
 Germany
 Tel. (49) 6105/2070
 Fax (49) 6105/207-100

All statements, technical information and recommendations related to the products herein are based upon information believed to be reliable or accurate. However, the accuracy or completeness thereof is not guaranteed, and no responsibility is assumed for any inaccuracies. Please contact MRV Communications for more information. MRV Communications and the MRV Communications logo are trademarks of MRV Communications, Inc. Other trademarks are the property of their respective holders.