

**Datasheet**

## 1.25 Gigabit Dual-Rate Single-Mode 50 km SFP Transceivers

SFP-GD-XD



### Highlights

- SFP transceiver
- Data Rates: 1.0625 – 1.25 Gbps
- Protocols:
  - 1 Gigabit Ethernet
  - 1 Gbps Fibre Channel
- Single-mode fiber
- Dual fiber, bi-directional
- 1550 nm
- 12 to 50 km
- Duplex LC connector
- Digital Diagnostics (SFF-8472)
- Hot-swap
- Industrial temperature modules available

### Overview

Small Form-Factor Pluggable (SFP) interfaces from MRV Communications provide flexible high speed links in a small industry standard package. They deliver the deployment options and inventory control that network administrators demand for growing networks.

SFPs are designed to Multi-Source Agreement (MSA) standards to ensure network equipment compatibility. They are a perfect addition to MRV’s extensive lines of networking equipment.

Visit the MRV website at [www.mrv.com](http://www.mrv.com) or contact your nearest authorized MRV Communications dealer for more information.

### Specifications Overview

Data Rate	1.0625 – 1.25 Gbps
Tx Wavelength	1550 nm
Tx Power (Minimum)	-5 dBm
Tx Dispersion Penalty	2 dB
Tx Disable	Yes
Rx Wavelength	1200 - 1625 nm
Rx Sensitivity	-24 dBm
Rx Saturation	-3 dBm
Rx Damage Threshold	6 dBm
Operating Temperature Range	-5 to 70 °C
Operating Temperature Range (TH Models)	-40 to 85 °C
Power Consumption	1 Watt

## Datasheet

### Optical Transmitter Specifications

Parameter	Symbol	Minimum	Maximum	Unit	Note
Optical Power	$P_{op}$	-5	0	dBm	-
Average Launch Power Tx_Off	$P_{off}$	-	-45	dBm	-
Extinction Ratio (Dynamic)	ER	9	-	dB	-
Eye Mask	-	802.3ah Compliant			-
Total Jitter	TJ	-	200	ps	-
Optical Rise/Fall Time	$t_r, t_f$	-	260	ps	1
Mean Wavelength	$\lambda$	1500	1580	nm	-
Spectral Width (20 dB)	$\lambda_c$	-	1	nm	-
Side Mode Suppression Ratio	SMSR	30	-	dB	-
Optical Path Penalty at 50 Km	dp	-	2	dB	2
Relative Intensity Noise	RIN	-	-120	dB/Hz	-
Reflection Tolerance	rp	-24	-	dB	3

- Notes:**
1. 20%~80% values
  2. Measured at BER of  $10^{-12}$  BER, PRBS  $2^7-1$ , at eye center
  3. 1 dB degradation of receiver sensitivity

### Optical Receiver Specifications

Parameter	Symbol	Minimum	Maximum	Unit	Note
Receiver Power Low	$R_{sens, low}$	-	-24	dBm	1
Receiver Power High	$R_{sens, high}$	-3	-	dBm	1
Damage Threshold For Receiver	$P_{in, damage}$	-	6	dBm	-
Wavelength	$\lambda$	1200	1625	nm	-
Maximum Reflectance of Receiver	RX_r	-	-12	dB	-
LOS Assert	-	-38	-	dBm	-
LOS De-Assert	-	-	-24	dBm	-
LOS Hysteresis	-	0.5	-	dB	-

- Notes:**
1.  $10^{-12}$  BER at nominal wavelength

### Digital Diagnostics

Parameter	Range	Accuracy	Unit	Calibration	Formula
Temperature	-5 to 70	$\pm 3$	°C	External	$T_c(C) = T_{slope} * T_{ad}(16 \text{ bit signed twos complement value}) + T_{offset}$
Temperature (TH Models)	-40 to 85	$\pm 3$	°C	External	$T_c(C) = T_{slope} * T_{ad}(16 \text{ bit signed twos complement value}) + T_{offset}$
Voltage	0 to $V_{CC}$	0.1	V	External	$V(\text{Volts}) = V_{slope} * V_{ad}(16 \text{ bit unsigned integer}) + V_{offset}$
Bias Current	0 to 120	$\pm 5$	mA	External	$I(\text{mA}) = I_{slope} * I_{ad}(16 \text{ bit unsigned integer}) + I_{offset}$
TX Power	-5 to 0	$\pm 3$	dBm	External	$Tx\_PWR(\mu W) = Tx\_PWR_{slope} * Tx\_PWR_{ad}(16 \text{ bit unsigned integer}) + Tx\_PWR_{offset}$
RX Power	-24 to -3	$\pm 3$	dBm	External	$RX\_PWR(\mu W) = A0 + A1 * x + A2 * x^2 + A3 * x^3 + A4 * x^4$

## Datasheet

### General Operating Conditions

Parameter	Symbol	Minimum	Maximum	Unit	Note
Supply Voltage	$V_{CC}$	3.135	3.465	V	-
Supply Current	$I_{CC}$	-	300	mA	-
Power Supply Noise Rejection	PSR	100	-	mVp-p	1
Operating Case Temperature	$T_{op}$	-5	70	°C	2
Operating Case Temperature (TH Models)	$T_{op}$	-40	85	°C	2
Storage Temperature	$T_{st}$	-40	85	°C	-
Data Rate GbE	DR	-	1.25	Gbps	-
Data Rate FC	DR	-	1.0625	Gbps	-

- Notes:**
1. 20 Hz to 155 MHz
  2. Please refer to the ordering information

### Electrical Transmitter Specifications

Parameter	Symbol	Minimum	Maximum	Unit	Note
Input Differential Impedance	$R_{in}$	80	120	$\Omega$	-
PECL Single Ended Data Input Swing	$V_{in, p-p}$	250	1200	mV	-
Tx_Fault_Fault	$V_{fault}$	2	$V_{CC}$	V	-
Tx_Fault_Normal	$V_{normal}$	$V_{EE}$	$V_{EE} + 0.5$	V	-
Tx_Disable_Disable	$V_d$	2	$V_{CC}$	V	-
Tx_Disable_Enable	$V_{en}$	$V_{EE}$	$V_{EE} + 0.8$	V	-

### Electrical Transmitter Specifications

Parameter	Symbol	Minimum	Maximum	Unit	Note
PECL Single Ended Data Output Swing	$V_{out, p-p}$	185	800	mV	-
Data Output Rise/Fall Time	$t_r/t_f$	-	260	ps	-

### Timing and Electrical Specifications

Parameter	Symbol	Minimum	Maximum	Unit	Note
Tx Disable Negate Time	$t_{on}$	-	1	ms	-
Tx Disable Assert Time	$t_{off}$	-	10	$\mu$ s	-
Time to Initialize, Including Reset of Tx Fault	$t_{init}$	-	300	ms	-
Tx Fault Assert Time	$t_{fault}$	-	100	$\mu$ s	-
Tx Disable to Reset	$t_{reset}$	10	-	$\mu$ s	-
LOS Assert Time	$t_{loss\_on}$	-	100	$\mu$ s	-
LOS De-Assert Time	$t_{loss\_off}$	-	100	$\mu$ s	-
Serial ID Clock Rate	$f_{serial\_clock}$	-	100	kHz	-
RX_LOS Voltage (High)	$Rx\_LOSS_H$	2	-	V	-
RX_LOS Voltage (Low)	$Rx\_LOSS_L$	-	0.8	V	-
LOS Output Voltage-Fault	$V_{LOS\ fault}$	2	$V_{CC}$	V	-
LOS Output Voltage-Normal	$V_{LOS\ normal}$	$V_{EE}$	$V_{EE} + 0.5$	V	-
MOD_DEF (0:2)-High	$V_H$	2	$V_{CC}$	V	-
MOD_DEF (0:2)-Low	$V_L$	$V_{EE}$	$V_{EE} + 0.5$	V	-

## Datasheet

### Pin Descriptions

Pin	Name		Note
1	VeeT	Transmitter Ground	-
2	TX_FAULT	Open Collector	-
3	TX_DISABLE	Internally Pulled High	-
4	MOD-DEF2	Serial Data Input	-
5	MOD-DEF1	Serial Clock Input	-
6	MOD-DEF0	Internally Grounded	-
7	NC	Not Connected	-
8	LOS	Open Collector	-
9	VeeR	Receiver Ground	-
10	VeeR	Receiver Ground	-
11	VeeR	Receiver Ground	-
12	RD-	Received Data Negative	-
13	RD+	Received Data Positive	-
14	VeeR	Receiver Ground	-
15	VccR	Receiver Power	-
16	VccT	Transmitter Power	-
17	VeeT	Transmitter Ground	-
18	TD+	Transmitter Data Positive	-
19	TD-	Transmitter Data Negative	-
20	VeeT	Transmitter Ground	-

### Mechanical Dimensions

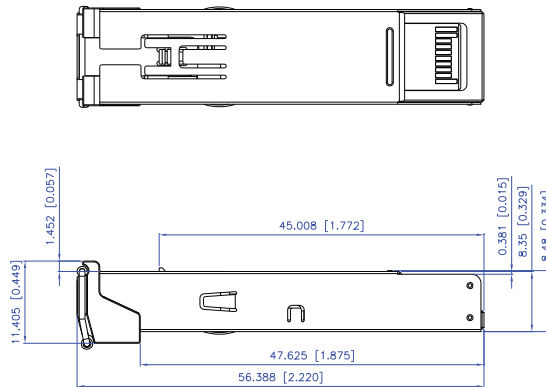
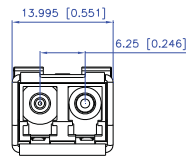

Units in mm(inch)

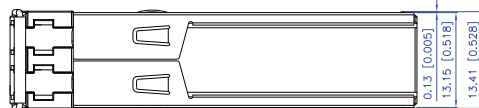



## Datasheet

### Ordering Information

Model	Description	Data Rate (Gbps)	Wavelength (nm)	Connector	Digital Diagnostics	Bail Latch Color	Maximum Distance Range (km)
SFP-GD-XD	1 Gigabit Ethernet and Fibre Channel Dual-Rate SFP Transceiver	1.0625 – 1.25	1550	Duplex LC	Yes	Green	12 - 50
SFP-GD-XDTH	1 Gigabit Ethernet and Fibre Channel Dual-Rate SFP Transceiver <i>Temperature Hardened</i>	1.0625 – 1.25	1550	Duplex LC	Yes	Green	12 - 50

### Regulatory and Industry Compliances

Class 1 Laser Product, complies with EN 60825-1 and 21 CFR 1040.10 except for deviations pursuant to Laser Notice No. 50, dated June 24, 2007  
MSA SFF-8074i; Telcordia GR-468, Digital Diagnostic SFF-8472  
Certified by one or more of the following agencies: TÜV, UL, CSA  
RoHS Directive; China RoHS; California RoHS Law, REACH Directive SVHC; WEEE Directive  
The Quality Management System is certified to ISO 9001 by QMI-SAI Global  
The Environmental Management System is in compliance with ISO 14001

### Warnings

**Handling Precautions:** This device is susceptible to damage as a result of electrostatic discharge (ESD). A static free environment is highly recommended. Follow guidelines according to proper ESD procedures.

**Laser Safety:** Radiation emitted by laser devices can be dangerous to human eyes. Avoid eye exposure to direct or indirect radiation.

MRV has more than 50 offices throughout the world. Addresses, phone numbers and fax numbers are listed at [www.mrv.com](http://www.mrv.com).  
Please e-mail us at [info@mrv.com](mailto:info@mrv.com) or call us for assistance.

MRV Los Angeles  
20415 Nordhoff Street  
Chatsworth, CA 91311  
800-338-5316  
818-773-0900

MRV Boston  
300 Apollo Drive  
Chelmsford, MA 01824  
800-338-5316  
978-674-6800

MRV International  
Business Park Moerfelden  
Waldeckerstrasse 13  
64546 Moerfelden-Walldorf  
Germany  
Tel. (49) 6105/2070  
Fax (49) 6105/207-100

All statements, technical information, and recommendations related to the products herein are based upon information believed to be reliable or accurate. However, the accuracy or completeness thereof is not guaranteed, and no responsibility is assumed for any inaccuracies. Please contact MRV Communications for more information. MRV Communications and the MRV Communications logo are trademarks of MRV Communications, Inc. Other trademarks are the property of their respective holders.