

**Datasheet**

**Multi-Rate (2 Gbps) Single-Mode 20 km SFP Transceivers**

SFP-MR27D-SR1



**Highlights**

- SFP transceiver
- Data Rates: 0.1 - 2.7 Gbps
- Protocols:
  - Fast Ethernet
  - 1 Gbps Ethernet
  - 1/2 Gbps Fibre Channel
  - Digital Video
  - OC-3/STM-1 to OC-48/STM-16 and OC-48 with FEC
- Single-mode fiber
- 1310 nm
- 0 to 20 km
- Duplex LC connector
- Digital Diagnostics (SFF-8472)
- Hot-swap
- Industrial temperature models available

**Overview**

Small Form-Factor Pluggable (SFP) interfaces from MRV Communications provide flexible high speed links in a small industry-standard package. They deliver the deployment options and inventory control that network administrators demand for growing networks.

SFPs are designed to Multi-Source Agreement (MSA) standards to ensure network equipment compatibility. They are a perfect addition to MRV’s extensive lines of networking equipment.

Visit the MRV website at [www.mrv.com](http://www.mrv.com) or contact your nearest authorized MRV Communications dealer for more information.

**Specifications Overview**

Data Rate	0.1 - 2.7 Gbps
Tx Wavelength	1310 nm
Tx Power (Minimum)	-10 dBm
Tx Disable	Yes
Rx Wavelength Range	1200 - 1625 nm
Rx Sensitivity	-20 dBm
Rx Saturation	-3 dBm
Damage Threshold	4 dBm
Operating Temperature Range	-5 to 70 °C
Operating Temperature Range (TH Models)	-40 to 85 °C
Power Consumption	1 Watt

## Datasheet

### Transmitter Specifications, Optical

Parameter	Symbol	Min	Max	Unit	Notes
Optical Power	Pop	-10	-3	dBm	-
Average Launch Power (Tx: Off)	Poff	-	-45	dBm	-
Extinction Ratio	ER	9	-	dB	-
Eye Mask	-	IEEE 802.3z and SONET/SDH compliant			-
Optical Jitter Generation	Jgen	-	0.007	UI	-
Optical Rise Time	t <sub>r</sub>	-	160	ps	1
Optical Fall Time	t <sub>f</sub>	-	160	ps	1
Mean Wavelength	λ	1266	1360	nm	-
Spectral Width (RMS)	Δλ	-	4	nm	-
Relative Intensity Noise	RIN	-	-120	dB/Hz	-
Reflectance Tolerance	rp	-24	-	dB	2

- Notes:**
1. 20% - 80% values
  2. 1 dB degradation of receiver sensitivity

### Receiver Specifications, Optical

Parameter	Symbol	Min	Max	Unit	Notes
Receive Power Low	R <sub>sens,low</sub>	-	-20	dBm	1
Receive Power High	R <sub>sens,high</sub>	-3	-	dBm	1
Damage Threshold	P <sub>in,damage</sub>	4	-	dBm	-
Wavelength	λ	1200	1625	nm	-
Maximum Reflectance	RX <sub>r</sub>	-	-27	dB	-
LOS Assert	-	-30	-	dBm	-
LOS De-assert	-	-	-20	dBm	-
LOS Hysteresis	-	0.5	-	dB	-

- Notes:**
1. Measured at 10<sup>-10</sup> BER, PRBS 2<sup>23</sup> -1 for SONET, 10<sup>-12</sup> BER, PRBS 2<sup>7</sup> -1 for Gigabit Ethernet

### Digital Diagnostics

Parameter	Range	Accuracy	Unit	Calibration	Formula
Temperature	-5 to 70	± 3	°C	External	Tc(C)=Tslope* <i>T</i> ad(16 bit signed twos complement value) + Toffset
Temperature (TH)	-40 to 85	± 3	°C	External	Tc(C)=Tslope* <i>T</i> ad(16 bit signed twos complement value) + Toffset
Voltage	0 to V <sub>CC</sub>	0.1	V	External	V(Volts)=Vslope* <i>V</i> ad(16 bit unsigned integer) + Voffset
Bias Current	0 to 120	5	mA	External	I(mA)=Islope* <i>I</i> ad(16 bit unsigned integer)+Ioffset
Tx Power	-10 to -3	±3 dB	dBm	External	Tx_PWR(μW)=Tx_PWRslope*Tx_PWRad(16 bit unsigned integer + Tx_PWRoffset
Rx Power	-20 to -3	±2 dB	dBm	External	Rx_PWR(μW)=A0+A1*x+A2*x^2+A3*x^3+A4*x^4

### General Operating

Parameter	Symbol	Min.	Max.	Unit	Notes
Supply Voltage	V <sub>CC</sub>	3.135	3.465	V	-
Total Current	I <sub>CC</sub>	-	300	mA	-
Power Supply Noise Rejection	PSR	100	-	mV <sub>p-p</sub>	1
Operating Temperature	T <sub>Op</sub>	-5	70	°C	-
Operating Temperature (TH Models)	T <sub>Op</sub>	-40	85	°C	-
Storage Temperature	T <sub>St</sub>	-40	85	°C	-
Data Rate	DR	0.1	2.7	Gbps	-

- Notes:**
1. 20 Hz to 155 MHz

## Datasheet

### Transmitter Specifications, Electrical

Parameter	Symbol	Min	Max	Unit	Notes
Input Differential Impedence	$R_{in}$	80	120	$\Omega$	-
PECL Single Ended Data Input Swing	$V_{in,p-p}$	250	1200	mV	-
TxFault_Fault	$V_{fault}$	2	$V_{cc}$	V	-
TxFault_Normal	$V_{normal}$	$V_{ee}$	$V_{ee}+0.5$	V	-
TxDisable_Disable	$V_d$	2	$V_{cc}$	V	-
TxDisable_Enable	$V_{en}$	$V_{ee}$	$V_{ee}+0.8$	V	-

### Electrical Output

Parameter	Symbol	Min	Max	Unit	Notes
PECL Single Ended Data Output Swing	$V_{out,p-p}$	185	800	mV	-
Data Output Rise Time	$t_r$	-	175	ps	-
Data Output Fall Time	$t_f$	-	175	ps	-

### Timing and Electrical

Parameter	Symbol	Min	Max	Unit	Notes
Tx Disable Negate Time	$t_{on}$	-	5	ms	-
Tx Disable Assert Time	$t_{off}$	-	10	$\mu s$	-
Time to Initialize, Including Reset of Tx Fault	$t_{init}$	-	300	ms	-
Tx Fault Assert Time	$t_{fault}$	-	100	$\mu s$	-
Tx Disable to Reset	$t_{reset}$	10	-	$\mu s$	-
LOS Assert Time	$t_{loss_{on}}$	-	100	$\mu s$	-
LOS De-assert Time	$t_{loss_{off}}$	-	100	$\mu s$	-
Serial ID Clock Rate	$f_{serial\_clock}$	-	100	KHz	-
RX_LOS Voltage (High)	$RX\_LOS_H$	2	-	V	-
RX_LOS Voltage (Low)	$RX\_LOS_L$	-	0.8	V	-
LOS Output Voltage-Fault	$V_{LOS\ fault}$	2	$V_{cc}$	V	-
LOS Output Voltage-Normal	$V_{LOS\ normal}$	$V_{ee}$	$V_{ee}+0.5$	V	-
MOD_DEF (0:2)-High	$V_h$	2	$V_{cc}$	V	-
MOD_DEF (0:2)-Low	$V_l$	$V_{ee}$	$V_{ee}+0.5$	V	-

**Datasheet**

Pin	Function	Notes
1	V <sub>ee</sub> T	TX Ground
2	TX_FAULT	Open Collector
3	TX_DISABLE	Internally Pulled High
4	MOD_DEF2	Serial Data Input
5	MOD_DEF1	Serial Clock Input
6	MOD_DEF0	Internally Grounded
7	NC	Not Connected
8	LOS	Open Collector
9	V <sub>ee</sub> R	RX Ground
10	V <sub>ee</sub> R	RX Ground
11	V <sub>ee</sub> R	RX Ground
12	RXD-	RX Data Negative
13	RXD+	RX Data Positive
14	V <sub>ee</sub> R	RX Ground
15	V <sub>cc</sub> R	RX Power
16	V <sub>cc</sub> T	TX Power
17	V <sub>ee</sub> T	TX Ground
18	TXD+	TX Data Positive
19	TXD-	TX Data Negative
20	V <sub>ee</sub> T	TX Ground

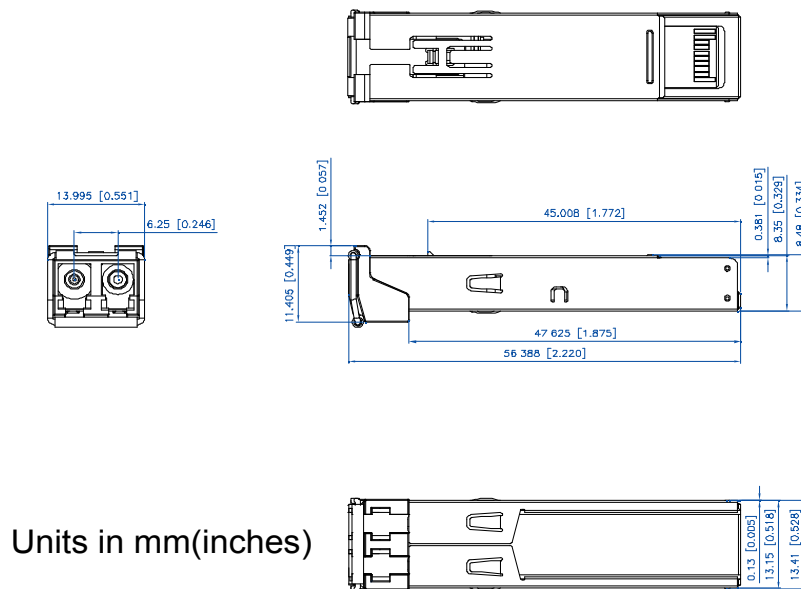
**Outline Drawing**



## Datasheet

### Ordering Information

Model	Description	Data Rate (Gbps)	Wavelength (nm)	Bail Latch Color	Distance Range (km)
<b>SFP-MR27D-SR1</b>	Multi-Rate (Ethernet, Fibre Channel, SONET, DV) SFP Transceiver with Digital Diagnostics	0.1 - 2.7	1310	Grey	0 -20
<b>SFP-MR27D-SR1TH</b>	Multi-Rate (Ethernet, Fibre Channel, SONET, DV) SFP Transceiver with Digital Diagnostics, <i>Temperature Hardened</i>	0.1 - 2.7	1310	Grey	0 -20

### Regulatory and Industry Compliances

Class 1 Laser Product, complies with EN 60825-1 and 21 CFR 1040.10 except for deviations pursuant to Laser Notice No. 50, dated June 24, 2007  
MSA SFF-8074i; Digital Diagnostic SFF-8472

Certified by one or more of the following agencies: TÜV, UL, CSA

RoHS Directive; China RoHS; California RoHS Law, REACH Directive SVHC; WEEE Directive

The Quality Management System is certified to ISO 9001 by QMI-SAI Global

The Environmental Management System is in compliance with ISO 14001

### Warnings

**Handling Precautions:** This device is susceptible to damage as a result of electrostatic discharge (ESD). A static free environment is highly recommended. Follow guidelines according to proper ESD procedures.

**Laser Safety:** Radiation emitted by laser devices can be dangerous to human eyes. Avoid eye exposure to direct or indirect radiation.

MRV has more than 50 offices throughout the world. Addresses, phone numbers and fax numbers are listed at [www.mrv.com](http://www.mrv.com).  
Please e-mail us at [info@mrv.com](mailto:info@mrv.com) or call us for assistance.

MRV Los Angeles  
20415 Nordhoff Street  
Chatsworth, CA 91311  
800-338-5316  
818-773-0900

MRV Boston  
300 Apollo Drive  
Chelmsford, MA 01824  
800-338-5316  
978-674-6800

MRV International  
Business Park Moerfelden  
Waldeckerstrasse 13  
64546 Moerfelden-Walldorf  
Germany  
Tel. (49) 6105/2070  
Fax (49) 6105/207-100

All statements, technical information, and recommendations related to the products herein are based upon information believed to be reliable or accurate. However, the accuracy or completeness thereof is not guaranteed, and no responsibility is assumed for any inaccuracies. Please contact MRV Communications for more information. MRV Communications and the MRV Communications logo are trademarks of MRV Communications, Inc. Other trademarks are the property of their respective holders.