

## Datasheet

# 125-155 Mbps Multi-mode SFP Transceivers

SFP-MR2-M



### Highlights

- SFP transceiver
- Data Rates: 125 - 155 Mbps
- Protocols:
  - SDH STM-1
  - SONET OC-3
  - Fast Ethernet
- Multi-mode fiber
- 1310 nm
- 0 - 2 km
- Duplex LC connector
- Hot-swap

### Overview

Small Form-Factor Pluggable (SFP) interfaces from MRV Communications provide flexible high speed links in a small industry standard package. They deliver the deployment options and inventory control that network administrators demand for growing networks.

SFPs are designed to Multi-Source Agreement (MSA) standards to ensure network equipment compatibility. They are a perfect addition to MRV's extensive lines of networking equipment.

Visit the MRV website at [www.mrv.com](http://www.mrv.com) or contact your nearest authorized MRV Communications dealer for more information.

### Specifications Overview

Data Rate	125 - 155 Mbps
Tx Wavelength	1310 nm
Tx Power (Minimum)	-20 dBm
Tx Disable	Yes
Rx Wavelength Range	1260 - 1570 nm
Rx Sensitivity	-30 dBm
Rx Saturation	-10 dBm
Operating Temperature Range	0 to 70 °C
Power Consumption	1 Watt

## Datasheet

### Transmitter Specifications (Optical and Electrical)

Parameter	Symbol	Min	Max	Unit	Notes
Center Wavelength	$\lambda_c$	1270	1380	nm	-
Average Output Power	$P_{OUT}$	-20	-14	dBm	1
$P_{OUT}$ @ TX Disable Asserted	$P_{OUT}$	-	-45	dBm	1
Spectral Width (RMS)	$\sigma$	-	7.7	nm	-
Extinction Ratio	EX	10	-	dB	-
Riise/Fall Time (20% - 80%)	$t_r/t_f$	-	3	ns	2
Output Optical Eye	Compliant with Eye Mask Bellcore TR-NWT-000253 for 100BASE-LX				3
Data Input Swing Differential	$V_{IN}$	500	1200	mV	4
Input Differential Impedence	$Z_{IN}$	80	120	$\Omega$	-
TxDisable_Disable	-	2.0	Vcc	V	-
TxDisable_Enable	-	Vee	Vee + 0.8	V	-
TxFault_Fault	-	2.0	Vcc	V	-
TxFault_Normal	-	Vee	Vee + 0.5	V	-

- Notes:**
1. The optical power is launched into MMF 62.5/125  $\mu$ m.
  2. Unfiltered, measured with 4B/5B code for 125 Mbps.
  3. Measured with 4B/5B code for 125 Mbps.
  4. Internally AC coupled, connected with 100 ohm differential load.

### Receiver Specifications (Optical and Electrical)

Parameter	Symbol	Min	Max	Unit	Notes
Center Wavelength	$\lambda_c$	1260	1570	nm	-
Receiver Sensitivity	-	-	-30	dBm	5
Receiver Overload	-	-10	-	dBm	5
Return Loss	-	12	-	dB	-
LOS De-Assert	-	-	-31	dBm	-
LOS Assert	-	-45	-	dBm	-
LOS Hysteresis	-	0.5	4.5	dB	-
Total Jitter	$T_J$	-	0.43	UI	-
Data Output Swing Differential	$V_{OUT}$	370	2000	mV	6
LOS High	-	2.0	Vcc + 0.3	V	-
LOS Low	-	Vee	Vee + 0.5	V	-

- Notes:**
5. Measured with a PRBS 2<sup>23</sup> - 1 test pattern @ 155Mbps, extinction ratio EX=10dB, BER  $\leq 1 \times 10^{-10}$ .
  6. Internally AC coupled.

### Absolute Maximum Rating

Parameter	Symbol	Min.	Max.	Unit	Notes
Storage Temperature	$T_S$	-40	85	°C	-
Supply Voltage	$V_{CC}$	-0.5	3.6	V	-
Operating Relative Humidity	-	5	95	%	-

### Recommended Operating Conditions

Parameter	Symbol	Min	Max	Unit	Notes
Operating Temperature (case)	$T_C$	0	70	°C	-
Power Supply Voltage	$V_{CC}$	3.13	3.47	V	-
Power Supply Total Current	$I_{CC}$	-	300	mA	-
Data Rate	DR	125	155	Mbps	-

## Datasheet

### Pin Function Definitions

Pin	Name	Function	Plug Sequence	Note
1	V <sub>eeT</sub>	Transmitter Ground	1	-
2	TX Fault	Transmitter Fault Indication	3	1
3	TX Disable	Transmitter Disable	3	2
4	MOD_DEF(2)	Module Definition 2	3	3
5	MOD_DEF(1)	Module Definition 1	3	3
6	MOD_DEF(0)	Module Definition 0	3	3
7	Rate Select	Not Connected	3	-
8	LOS	Loss of Signal Indication	3	4
9	V <sub>eeR</sub>	Receiver Ground	1	-
10	V <sub>eeR</sub>	Receiver Ground	1	-
11	V <sub>eeR</sub>	Receiver Ground	1	-
12	RD-	Inverted Receiver Data Out	3	5
13	RD+	Receiver Data Out	3	5
14	V <sub>eeR</sub>	Receiver Ground	1	-
15	V <sub>ccR</sub>	Receiver Power	2	-
16	V <sub>ccT</sub>	Transmitter Power	2	-
17	V <sub>eeT</sub>	Transmitter Ground	1	-
18	TD+	Transmitter Data In	3	6
19	TD-	Inverted Transmitter Data In	3	6
20	V <sub>eeT</sub>	Transmitter Ground	1	-

- Notes:**
- TX Fault is an open collector output, which should be pulled up with a 4.7 k~10 kΩ resistor on the host board to a voltage between 2.0 V and V<sub>cc</sub>+0.3 V. Logic 0 indicates normal operation; logic 1 indicates a laser fault of some kind. In the low state, the output will be pulled to less than 0.8 V.
  - TX Disable is an input that is used to shut down the transmitter optical output. It is pulled up within the module with a 4.7 k~10 kΩ resistor. Its states are:  
 Low (0~0.8 V): Transmitter on  
 (>0.8 V, <2.0 V): Undefined  
 High (2.0~3.465 V): Transmitter Disabled  
 Open: Transmitter Disabled
  - MOD-DEF 0,1,2 are the module definition pins. They should be pulled up with a 4.7 k~10 kΩ resistor on the host board. The pull-up voltage shall be V<sub>ccT</sub> or V<sub>ccR</sub>.  
 MOD-DEF 0 is grounded by the module to indicate that the module is present  
 MOD-DEF 1 is the clock line of two wires serial interface for serial ID  
 MOD-DEF 2 is the data line of two wires serial interface for serial ID
  - LOS is an open collector output, which should be pulled up with a 4.7 k~10 kΩ resistor on the host board to a voltage between 2.0 V and V<sub>cc</sub>+0.3 V. Logic 0 indicates normal operation; logic 1 indicates loss of signal. In the low state, the output will be pulled to less than 0.8 V.
  - These are the differential receiver output. They are internally AC-coupled 100 Ω differential lines which should be terminated with 100 Ω (differential) at the user SERDES.
  - These are the differential transmitter inputs. They are AC-coupled, differential lines with 100 Ω differential termination inside the module.

## Datasheet

### Mechanical Drawing

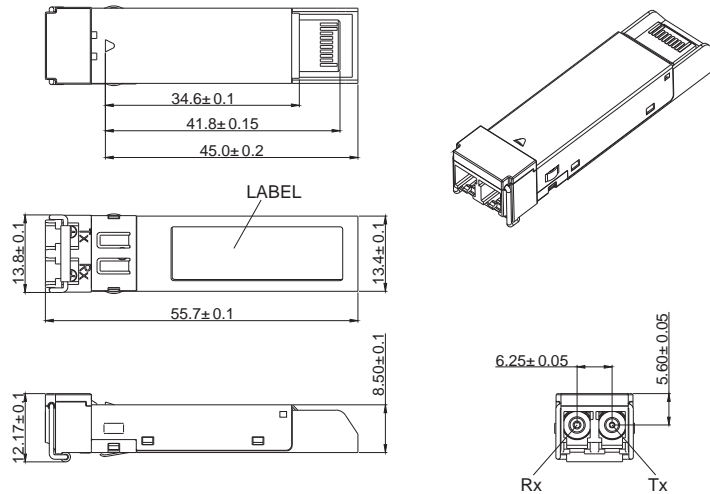

### Ordering Information

Model	Description	Data Rate (Mbps)	Wavelength (nm)	Connector	Bail Latch Color	Maximum Distance Range (km)
SFP-MR2-M	SDH STM-1, SONET OC-3 SR1, Fast Ethernet SFP Transceiver, MM	125 - 155	1310	Duplex LC	Gray	0 - 2

### Regulatory and Industry Compliances

Class 1 Laser Product, complies with EN 60825-1 and 21 CFR 1040.10 except for deviations pursuant to Laser Notice No. 50. dated June 24, 2007  
 MSA SFF-8074i  
 Certified by one or more of the following agencies: TÜV, UL, CSA  
 RoHS Directive; China RoHS; California RoHS Law, REACH Directive SVHC; WEEE Directive  
 The Quality Management System is certified to ISO 9001 by QMI-SAI Global  
 The Environmental Management System is in compliance with ISO 14001

### Warnings

**Handling Precautions:** This device is susceptible to damage as a result of electrostatic discharge (ESD). A static free environment is highly recommended. Follow guidelines according to proper ESD procedures.

**Laser Safety:** Radiation emitted by laser devices can be dangerous to human eyes. Avoid eye exposure to direct or indirect radiation.

MRV has more than 50 offices throughout the world. Addresses, phone numbers and fax numbers are listed at [www.mrv.com](http://www.mrv.com). Please e-mail us at [info@mrv.com](mailto:info@mrv.com) or call us for assistance.

MRV Los Angeles  
 20415 Nordhoff Street  
 Chatsworth, CA 91311  
 800-338-5316  
 818-773-0900

MRV Boston  
 300 Apollo Drive  
 Chelmsford, MA 01824  
 800-338-5316  
 978-674-6800

MRV International  
 Business Park Moerfelden  
 Waldeckerstrasse 13  
 64546 Moerfelden-Walldorf  
 Germany  
 Tel. (49) 6105/2070  
 Fax (49) 6105/207-100

All statements, technical information, and recommendations related to the products herein are based upon information believed to be reliable or accurate. However, the accuracy or completeness thereof is not guaranteed, and no responsibility is assumed for any inaccuracies. Please contact MRV Communications for more information. MRV Communications and the MRV Communications logo are trademarks of MRV Communications, Inc. Other trademarks are the property of their respective holders.