

## Datasheet

# 2.7 Gbps Multi-Rate Single Fiber Bidirectional 15 km SFP Transceivers

SFP-MR-351R1 and SFP-MR-531R1



### Highlights

- SFP transceiver
- Data Rates: 100 to 2700 Mbps
- Protocols:
  - IEEE 802.3ah
  - Gigabit Ethernet
  - OC-48/STM-16
- Single-mode fiber
- Single fiber, bi-directional
- Two wavelength options:
  - Tx 1310 nm and Rx 1550 nm
  - Tx 1550 nm and Rx 1310 nm
- 0 to 15 km
- Simplex LC connector
- Digital Diagnostics (SFF-8472)
- Industrial temperature models available
- Hot-swap

### Overview

Small Form-Factor Pluggable (SFP) interfaces from MRV Communications provide flexible high speed links in a small industry standard package. They deliver the deployment options and inventory control that network administrators demand for growing networks.

SFPs are designed to Multi-Source Agreement (MSA) standards to ensure network equipment compatibility. They are a perfect addition to MRV's extensive lines of networking equipment.

Visit the MRV website at [www.mrv.com](http://www.mrv.com) or contact your nearest authorized MRV Communications dealer for more information.

### Specifications Overview

Data Rate	100 to 2700 Mbps
Tx Wavelength for SFP-MR-351R1	1310 nm
Tx Wavelength for SFP-MR-531R1	1550 nm
Tx Power (Minimum)	-5 dBm
Tx Dispersion Penalty	1 dB
Tx Extinction Ratio	8.2 dBm
Tx Disable	Yes
Rx Wavelength for SFP-MR-351R1	1480 to 1600 nm
Rx Wavelength for SFP-MR-531R1	1260 to 1360 nm
Rx Sensitivity	-22 dBm
Rx Saturation	0 dBm
Rx Damage Threshold	0 dBm
Operating Temperature Range	-5 to 70 °C
Operating Temperature Range (TH Models)	-40 to 85 °C
Power Consumption	1 Watt

## Datasheet

### Transmitter Specifications (Optical)

Parameter	Symbol	Min	Max	Unit	Notes
Optical Power	$P_{op}$	-5	0	dBm	-
Optical Crosstalk	XT	-	-45	dB	-
Average Launch Power of Off Tx	$P_{off}$	-	-45	dBm	-
Extinction Ratio	ER	8.2	-	dB	-
Eye Mask	-	IEEE 802.3 and SONET/SDH compliant			-
Optical Rise Time (20% to 80% values)	$t_r$	-	160	ps	-
Optical Fall Time (20% to 80% values)	$t_f$	-	160	ps	-
Mean Wavelength for SFP-MR-35IR1	$\lambda$	1280	1335	nm	-
Mean Wavelength for SFP-MR-53IR1	$\lambda$	1480	1580	nm	-
RMS Width (20 dB)	$\Delta\lambda$	-	1	nm	-
Side Mode Suppression Ratio	SMSR	30	-	dB	-
Dispersion Penalty (at 15 km)	dp	-	1	dB	1
Relative Intensity Noise	RIN	-	-120	dB/Hz	-
Transmitter Reflectance	-	-	-12	dB	-
Reflectance Tolerance	rp	-24	-	dB	-

**Notes:** 1. Measured at 2.7 Gbps,  $10^{-12}$  BER, PRBS  $2^{23}-1$ , at eye center

### Receiver Specifications (Optical)

Parameter	Symbol	Min	Max	Unit	Notes
Receive Power	$R_{sens,low/high}$	-18	0	dBm	1
Damage Threshold	$P_{in,damage}$	0	-	dBm	-
Wavelength for SFP-MR-35IR1	$\lambda$	1480	1600	nm	-
Wavelength for SFP-MR-53IR1	$\lambda$	1260	1360	nm	-
LOS Assert	-	-28	-	dBm	-
LOS De-assert	-	-	-18	dBm	-
LOS Hysteresis	-	0.5	-	dB	-
Receiver Reflectance	-	-	-12	dB	-

**Notes:** 1. Measured at  $10^{-10}$  BER, 2.7 Gbps, PRBS  $2^{23}-1$ , and  $10^{-12}$  BER, 1.25 Gbps, PRBS  $2^7-1$

### Digital Diagnostics

Parameter	Range	Accuracy	Unit	Calibration	Formula
Temperature	-5 to 70	$\pm 3$	°C	External	$T_c(C) = T_{slope} * T_{ad}(16 \text{ bit signed twos complement value}) + T_{offset}$
Temperature (TH)	-40 to 85	$\pm 3$	°C	External	$T_c(C) = T_{slope} * T_{ad}(16 \text{ bit signed twos complement value}) + T_{offset}$
Voltage	0 to $V_{CC}$	$\pm 0.1$	V	External	$V(\text{Volts}) = V_{slope} * V_{ad}(16 \text{ bit unsigned integer}) + V_{offset}$
Bias Current	0 to 120	$\pm 5$	mA	External	$I(\text{mA}) = I_{slope} * I_{ad}(16 \text{ bit unsigned integer}) + I_{offset}$
TX Power	-5 to 0	$\pm 3$	dBm	External	$TX\_PWR(\mu W) = TX\_PWR_{slope} * TX\_PWR_{ad}(16 \text{ bit unsigned integer}) + TX\_PWR_{offset}$
RX Power	-18 to 0	$\pm 3$	dBm	External	$RX\_PWR(\mu W) = A_0 + A_1 * x + A_2 * x^2 + A_3 * x^3 + A_4 * x^4$

## Datasheet

### General Operations

Parameter	Symbol	Min	Max	Unit	Notes
Supply Voltage	$V_{CC}$	3.135	3.465	V	-
Total Current	$I_{CC}$	-	300	mA	-
Power Supply Noise Rejection	PSR	100	-	mV <sub>p-p</sub>	-
Operating Case Temperature	$T_{opr}$	-5	70	°C	1
Operating Case Temperature (TH Models)	$T_{opr}$	-40	85	°C	-
Storage Temperature	$T_{stg}$	-40	85	°C	-
Data Rate OC-48	DR	-	2488.32	Mbps	-
Data Rate FEC	DR	-	2700	Mbps	-
Data Rate Gigabit Ethernet	DR	-	1250	Mbps	-
Data Rate Fibre Channel	DR	-	1062.5	Mbps	-
Data Rate 2 Gigabit Fibre Channel	DR	-	2125	Mbps	-
Data Rate	DR	100	2700	Mbps	-

**Notes:** 1. Maximum Relative Humidity is 85%, non-condensing

### Transmitter Specifications (Electical)

Parameter	Symbol	Min	Max	Unit	Notes
Input Differential Impedence	$R_{in}$	80	120	$\Omega$	-
PECL Single Ended Data Input Swing	$V_{in,p-p}$	250	1200	mV	-
TxFault_Fault	$V_{fault}$	2	$V_{CC}$	V	-
TxFault_Normal	$V_{normal}$	$V_{EE}$	$V_{EE}+0.5$	V	-
TxDisable_Disable	$V_d$	2	$V_{CC}$	V	-
TxDisable_Enable	$V_{en}$	$V_{EE}$	$V_{EE}+0.8$	V	-

### Receiver Specifications (Electrical)

Parameter	Symbol	Min	Max	Unit	Notes
PECL Single Ended Data Output Swing	$V_{out,p-p}$	185	800	mV	-
Data Output Rise Time	$t_r$	-	175	ps	-
Data Output Fall Time	$t_f$	-	175	ps	-

### Electrical Specifications and Timing

Parameter	Symbol	Min	Max	Unit	Notes
Tx Disable Negate Time	$t_{on}$	-	1	ms	-
Tx Disable Assert Time	$t_{off}$	-	10	$\mu$ s	-
Time to Initialize, Including Reset of Tx Fault	$t_{init}$	-	300	ms	-
Tx Fault Assert Time	$t_{fault}$	-	100	$\mu$ s	-
Tx Disable To Reset	$t_{reset}$	10	-	$\mu$ s	-
LOS Assert Time	$t_{loss_{on}}$	-	100	$\mu$ s	-
LOS De-assert Time	$t_{loss_{off}}$	-	100	$\mu$ s	-
Serial ID Clock Rate	$f_{serial\_clock}$	-	100	KHz	-
RX_LOS Voltage (High)	$RX\_LOS_H$	2	$V_{CC}$	V	-
RX_LOS Voltage (Low)	$RX\_LOS_L$	-	0.8	V	-
LOS Output Voltage-Fault	$V_{LOS\ fault}$	2	$V_{CC}$	V	-
LOS Output Voltage-Normal	$V_{LOS\ normal}$	$V_{EE}$	$V_{EE}+0.5$	V	-
MOD_DEF (0:2)-High	$V_H$	2	$V_{CC}$	V	-
MOD_DEF (0:2)-Low	$V_L$	$V_{EE}$	$V_{EE}+0.5$	V	-

**Datasheet**

Pin	Function	Name / Description	Notes
1	V <sub>ee</sub> T	Module Transmitter Ground	-
2	TX_FAULT	Open Collector	-
3	TX_DISABLE	Internally Pulled High	-
4	MOD_DEF2	Serial Data Input	-
5	MOD_DEF1	Serial Clock Input	-
6	MOD_DEF0	Internally Grounded	-
7	NC	Not Connected	-
8	LOS	Open Collector	-
9	V <sub>ee</sub> R	Module Receiver Ground	-
10	V <sub>ee</sub> R	Module Receiver Ground	-
11	V <sub>ee</sub> R	Module Receiver Ground	-
12	RXD-	Receiver Data Negative	-
13	RXD+	Receiver Data Positive	-
14	V <sub>ee</sub> R	Module Receiver Ground	-
15	V <sub>cc</sub> R	Module Receiver Power Supply	-
16	V <sub>cc</sub> T	Module Transmitter Power Supply	-
17	V <sub>ee</sub> T	Module Transmitter Ground	-
18	TXD+	Transmitter Data Positive	-
19	TXD-	Transmitter Data Negative	-
20	V <sub>ee</sub> T	Module Transmitter Ground	-

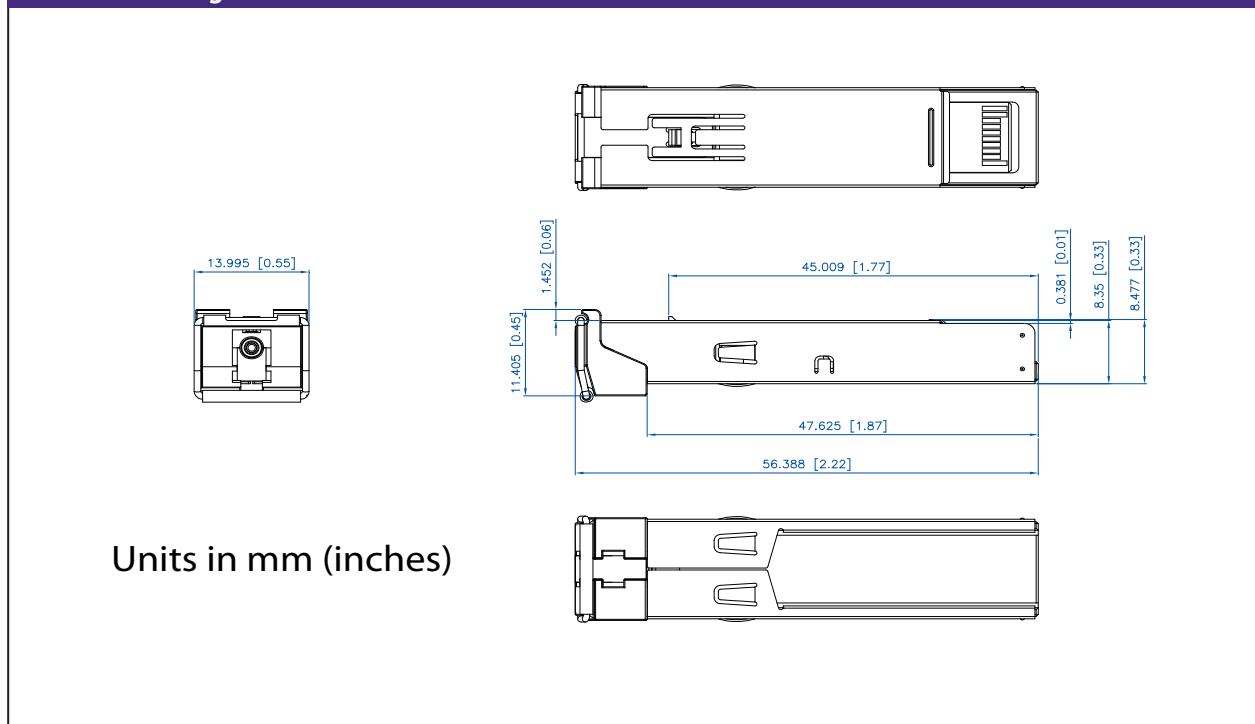
**Outline Drawing**



## Datasheet

### Ordering Information

Model	Description	Data Rate (Mbps)	Wavelength (nm)		Connector Type	Digital Diagnostics	Bail Latch Color	Distance Range (km)
			Tx	Rx				
<b>SFP-MR-35IR1</b>	SFP Mult-Rate Bidirectional Transceiver	100 - 2700	1310	1550	LC	Yes	Blue	0 - 15
<b>SFP-MR-53IR1</b>	SFP Mult-Rate Bidirectional Transceiver	100 - 2700	1550	1310	LC	Yes	Yellow	0 - 15
<b>SFP-MR-35IR1TH</b>	SFP Mult-Rate Bidirectional Transceiver, <i>Temperature Hardened</i>	100 - 2700	1310	1550	LC	Yes	Blue	0 - 15
<b>SFP-MR-53IR1TH</b>	SFP Mult-Rate Bidirectional Transceiver, <i>Temperature Hardened</i>	100 - 2700	1550	1310	LC	Yes	Yellow	0 - 15

### Regulatory and Industry Compliances

Class 1 Laser Product, complies with EN 60825-1 and 21 CFR 1040.10 except for deviations pursuant to Laser Notice No. 50, dated June 24, 2007  
MSA SFF-8074i; Telcordia GR-468, GR 253/STM G.957, Digital Diagnostic SFF-8472;

Certified by one or more of the following agencies: TÜV, UL, CSA

RoHS Directive; China RoHS; California RoHS Law, REACH Directive SVHC; WEEE Directive

The Quality Management System is certified to ISO 9001 by QMI-SAI Global

The Environmental Management System is in compliance with ISO 14001

### Warnings

**Handling Precautions:** This device is susceptible to damage as a result of electrostatic discharge (ESD). A static free environment is highly recommended. Follow guidelines according to proper ESD procedures.

**Laser Safety:** Radiation emitted by laser devices can be dangerous to human eyes. Avoid eye exposure to direct or indirect radiation.

MRV has more than 50 offices throughout the world. Addresses, phone numbers and fax numbers are listed at [www.mrv.com](http://www.mrv.com).  
Please e-mail us at [info@mrv.com](mailto:info@mrv.com) or call us for assistance.

MRV Los Angeles  
20415 Nordhoff Street  
Chatsworth, CA 91311  
800-338-5316  
818-773-0900

MRV Boston  
300 Apollo Drive  
Chelmsford, MA 01824  
800-338-5316  
978-674-6800

MRV International  
Business Park Moerfelden  
Waldeckerstrasse 13  
64546 Moerfelden-Walldorf  
Germany  
Tel. (49) 6105/2070  
Fax (49) 6105/207-100

All statements, technical information, and recommendations related to the products herein are based upon information believed to be reliable or accurate. However, the accuracy or completeness thereof is not guaranteed, and no responsibility is assumed for any inaccuracies. Please contact MRV Communications for more information. MRV Communications and the MRV Communications logo are trademarks of MRV Communications, Inc. Other trademarks are the property of their respective holders.