

Datasheet

622 Mbps Single-Mode 48 km SFP Transceivers

SFP-O12D-LR1



Highlights

- SFP transceiver
- Data Rates: 622 Mbps
- Protocols:
 - SDH STM-4
 - SONET OC-12
- Single-mode fiber
- 1310 nm
- 20 to 48 km
- Duplex LC connector
- Digital Diagnostics (SFF-8472)
- Hot-swap
- Industrial temperature models available

Overview

Small Form-Factor Pluggable (SFP) interfaces from MRV Communications provide flexible high speed links in a small industry-standard package. They deliver the deployment options and inventory control that network administrators demand for growing networks.

SFPs are designed to Multi-Source Agreement (MSA) standards to ensure network equipment compatibility. They are a perfect addition to MRV's extensive lines of networking equipment.

Visit the MRV website at www.mrv.com or contact your nearest authorized MRV Communications dealer for more information.

Specifications Overview

| | |
|---|----------------|
| Data Rate | 622 Mbps |
| Tx Wavelength | 1310 nm |
| Tx Power (Minimum) | -3 dBm |
| Dispersion Penalty | 1 dB |
| Tx Disable | Yes |
| Rx Wavelength Range | 1200 - 1625 nm |
| Rx Sensitivity | -28 dBm |
| Rx Saturation | -8 dBm |
| Rx Damage Threshold | 0 dBm |
| Operating Temperature Range | 0 to 70 °C |
| Operating Temperature Range (TH Models) | -40 to 85 °C |
| Power Consumption | 1 Watt |

Datasheet

Transmitter Specifications, Optical

| Parameter | Symbol | Minimum | Maximum | Unit | Note |
|--------------------------------|------------------|---------------------|---------|-------|------|
| Optical Power | P _{OP} | -3 | 2 | dBm | - |
| Average Launch Power Of Off Tx | P _{Off} | - | -30 | dBm | - |
| Extinction Ratio | ER | 8.2 | - | dB | - |
| Eye Mask | - | SONET/SDH compliant | | | - |
| Optical Jitter Generation | J _{gen} | - | 0.002 | UI | - |
| Optical Rise Time | t _r | - | 500 | ps | 1 |
| Optical Fall Time | t _f | - | 500 | ps | 1 |
| Mean Wavelength | λ | 1296 | 1330 | nm | - |
| Spectral Width (RMS) | Δλ | - | 1.7 | nm | - |
| Dispersion Penalty (at 40 Km) | - | - | 1 | dB | - |
| Relative Intensity Noise | RIN | - | -120 | dB/Hz | - |

Notes: 1. 20%-80% values

Receiver Specifications, Optical

| Parameter | Symbol | Minimum | Maximum | Unit | Note |
|-------------------------------|------------------------|---------|---------|------|------|
| Receive Power Low | R _{sens,low} | - | -28 | dBm | 1 |
| Receive Power High | R _{sens,high} | -8 | - | dBm | - |
| Damage Threshold for Receiver | P _{in,damage} | 0 | - | dBm | - |
| Wavelength | λ | 1260 | 1360 | nm | 2 |
| LOS Assert | LOS _A | -38 | - | dBm | - |
| LOS De-Assert | LOS _D | - | -28 | dBm | - |
| LOS Hysteresis | - | 0.5 | - | dB | - |

Notes: 1. 10⁻¹² at nominal wavelength
2. Operational over 1200 to 1625 nm range

Monitoring Specifications

| Parameter | Range | Accuracy | Unit | Calibration | Formula |
|-------------------------|----------------------|----------|------|-------------|--|
| Temperature | -5 to 70 °C | ± 3 | °C | Internal | Tc(C)=Tad(16 bit signed twos complement)/256 |
| Temperature (TH Models) | -40 to 85 °C | ± 3 | °C | Internal | Tc(C)=Tad(16 bit signed twos complement)/256 |
| Voltage | 0 to V _{CC} | ± 0.1 | V | Internal | V(Volts)=Vad(16 bit unsigned integer)*0.1 |
| Bias Current | 0 to 120 | ± 5 | mA | External | I(mA)=Islope*Iad(16 bit unsigned integer)+Ioffset |
| Tx Power | -3 to 2 | ± 3 | dBm | External | TX_PWR(μW)=TX_PWRslope*TX_PWRad (16 bit unsigned integer) +TX_PWRoffset |
| Rx Power | -28 to -8 | ± 3 | dBm | External | RX_PWR(μW)=A0+A1*x+A2*x^2+A3*x^3+A4*x^4 |

General Operations

| Parameter | Symbol | Minimum | Maximum | Unit | Note |
|--|-----------------|---------|---------|-------------------|------|
| Supply Voltage | V _{CC} | 3.135 | 3.465 | V | - |
| Total Current | I _{CC} | - | 300 | mA | - |
| Power Supply Noise Rejection | PSR | 100 | - | mV _{p-p} | 1 |
| Operating Case Temperature | T _{op} | -5 | 70 | °C | - |
| Operating Case Temperature (TH Models) | T _{op} | -40 | 85 | °C | - |
| Storage Temperature | T _{st} | -40 | 85 | °C | - |
| Data Rate OC-12/STM-4 | DR | - | 622 | Mbps | - |

Notes: 1. 20 Hz to 155 MHz

Datasheet

Transmitter Specifications, Electrical

| Parameter | Symbol | Minimum | Maximum | Unit | Note |
|------------------------------------|--------------|----------|--------------|----------|------|
| Input Differential Impedence | R_{in} | 80 | 120 | Ω | - |
| PECL Single Ended Data Input Swing | $V_{in,p-p}$ | 250 | 1200 | mV | - |
| TxFault_Fault | V_{fault} | 2 | V_{cc} | V | - |
| TxFault_Normal | V_{normal} | V_{ee} | $V_{ee}+0.5$ | V | - |
| TxDisable_Disable | V_d | 2 | V_{cc} | V | - |
| TxDisable_Enable | V_{en} | V_{ee} | $V_{ee}+0.8$ | V | - |

Electrical Output

| Parameter | Symbol | Minimum | Maximum | Unit | Note |
|-------------------------------------|---------------|---------|---------|------|------|
| PECL Single Ended Data Output Swing | $V_{out,p-p}$ | 185 | 800 | mV | - |
| Data Output Rise Time | t_r | - | 500 | ps | - |
| Data Output Fall Time | t_f | - | 500 | ps | - |

Timing and Electrical

| Parameter | Symbol | Minimum | Maximum | Unit | Note |
|---|---------------------|----------|--------------|---------|------|
| Tx Disable Negate Time | t_{on} | - | 1 | ms | - |
| Tx Disable Assert Time | t_{off} | - | 10 | μs | - |
| Time To Initialize, Including Reset Of Tx Fault | t_{init} | - | 300 | ms | - |
| Tx Fault Assert Time | t_{fault} | - | 100 | μs | - |
| Tx Disable To Reset | t_{reset} | 10 | - | μs | - |
| Los Assert Time | t_{loss_on} | - | 100 | μs | - |
| Los De-assert Time | t_{loss_off} | - | 100 | μs | - |
| Serial ID Clock Rate | f_{serial_clock} | - | 100 | KHz | - |
| RX_LOS Voltage (High) | - | 2 | - | V | - |
| RX_LOS Voltage (Low) | - | - | 0.8 | V | - |
| LOS Output Voltage-Fault | V_{LOS_fault} | 2 | V_{cc} | V | - |
| LOS Output Voltage-Normal | V_{LOS_normal} | V_{ee} | $V_{ee}+0.5$ | V | - |
| MOD_DEF (0:2)-High | V_h | 2 | V_{cc} | V | - |
| MOD_DEF (0:2)-LOW | V_l | V_{ee} | $V_{ee}+0.5$ | V | - |

Datasheet

Pin Descriptions

| Pin | Function | Name/Description |
|-----|-------------------|---------------------------|
| 1 | V _{ee} T | Transmitter Ground |
| 2 | Tx_Fault | Open Collector |
| 3 | Tx_Disable | Internally Pulled High |
| 4 | MOD_DEF(2) | Serial Data Input |
| 5 | MOD_DEF(1) | Serial Clock Input |
| 6 | MOD_DEF(0) | Internally Grounded |
| 7 | NC | Not Connected |
| 8 | LOS | Open Collector |
| 9 | V _{ee} R | Receiver Ground |
| 10 | V _{ee} R | Receiver Ground |
| 11 | V _{ee} R | Receiver Ground |
| 12 | RXD- | Receiver Data Negative |
| 13 | RXD+ | Receiver Data Positive |
| 14 | V _{ee} R | Receiver Ground |
| 15 | V _{cc} R | Receiver Power |
| 16 | V _{cc} T | Transmitter Power |
| 17 | V _{ee} T | Transmitter Ground |
| 18 | TXD+ | Transmitter Data Positive |
| 19 | TXD- | Transmitter Data Negative |
| 20 | V _{ee} T | Transmitter Ground |

Mechanical Dimensions

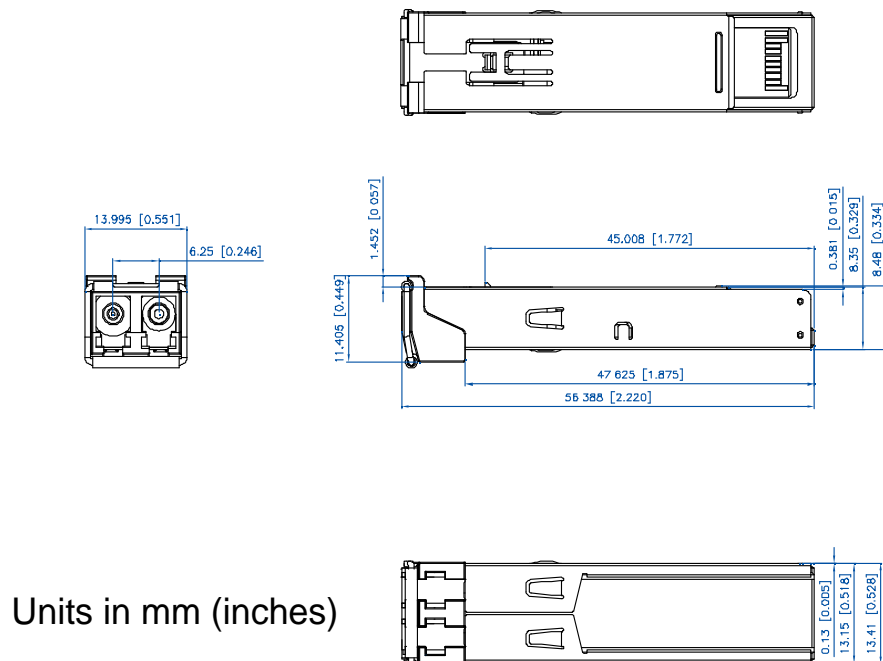



Datasheet

Ordering Information

| Model | Description | Data Rate (Mbps) | Wavelength (nm) | Connector | Bail Latch Color | Digital Diagnostics | Maximum Distance Range (km)* |
|----------------|---|------------------|-----------------|-----------|------------------|---------------------|------------------------------|
| SFP-O12D-LR1 | SDH STM-4, SONET OC-12 SFP Transceiver | 622 | 1310 | Duplex LC | Red | Yes | 20 - 48 |
| SFP-O12D-LR1TH | SDH STM-4, SONET OC-12 SFP Transceiver, <i>Temperature Hardened</i> | 622 | 1310 | Duplex LC | Red | Yes | 20 - 48 |

* Maximum range quoted is not possible with all wavelength and/or fiber. Please consult MRV.

Regulatory and Industry Compliances

Class 1 Laser Product, complies with EN 60825-1 and 21 CFR 1040.10 except for deviations pursuant to Laser Notice No. 50. dated June 24, 2007
MSA SFF-8074i; Digital Diagnostic SFF-8472

Certified by one or more of the following agencies: TÜV, UL, CSA

RoHS Directive; China RoHS; California RoHS Law, REACH Directive SVHC; WEEE Directive

The Quality Management System is certified to ISO 9001 by QMI-SAI Global

The Environmental Management System is in compliance with ISO 14001

Warnings

Handling Precautions: This device is susceptible to damage as a result of electrostatic discharge (ESD). A static free environment is highly recommended. Follow guidelines according to proper ESD procedures.

Laser Safety: Radiation emitted by laser devices can be dangerous to human eyes. Avoid eye exposure to direct or indirect radiation.

MRV has more than 50 offices throughout the world. Addresses, phone numbers and fax numbers are listed at www.mrv.com.
Please e-mail us at info@mrv.com or call us for assistance.

MRV Los Angeles
20415 Nordhoff Street
Chatsworth, CA 91311
800-338-5316
818-773-0900

MRV Boston
300 Apollo Drive
Chelmsford, MA 01824
800-338-5316
978-674-6800

MRV International
Business Park Moerfelden
Waldeckerstrasse 13
64546 Moerfelden-Walldorf
Germany
Tel. (49) 6105/2070
Fax (49) 6105/207-100

All statements, technical information, and recommendations related to the products herein are based upon information believed to be reliable or accurate. However, the accuracy or completeness thereof is not guaranteed, and no responsibility is assumed for any inaccuracies. Please contact MRV Communications for more information. MRV Communications and the MRV Communications logo are trademarks of MRV Communications, Inc. Other trademarks are the property of their respective holders.