

Datasheet

622 Mbps Single-Mode 80 km SFP Transceivers

SFP-O12D-LR2



Highlights

- SFP transceiver
- Data Rates: 622 Mbps
- Protocols:
 - SDH STM-4
 - SONET OC-12
- Single-mode fiber
- 1550 nm
- 20 to 80 km
- Duplex LC connector
- Digital Diagnostics (SFF-8472)
- Hot-swap
- Industrial temperature models available

Overview

Small Form-Factor Pluggable (SFP) interfaces from MRV Communications provide flexible high speed links in a small industry-standard package. They deliver the deployment options and inventory control that network administrators demand for growing networks.

SFPs are designed to Multi-Source Agreement (MSA) standards to ensure network equipment compatibility. They are a perfect addition to MRV's extensive lines of networking equipment.

Visit the MRV website at www.mrv.com or contact your nearest authorized MRV Communications dealer for more information.

Specifications Overview

Data Rate	622 Mbps
Tx Wavelength	1550 nm
Tx Power (Minimum)	-3 dBm
Dispersion Penalty	1 dB
Tx Disable	Yes
Rx Wavelength Range	1200 - 1625 nm
Rx Sensitivity	-28 dBm
Rx Saturation	-8 dBm
Rx Damage Threshold	0 dBm
Operating Temperature Range	-5 to 70 °C
Operating Temperature Range (TH Models)	-40 to 85 °C
Power Consumption	1 Watt

Datasheet

Transmitter Specifications, Optical

Parameter	Symbol	Minimum	Maximum	Unit	Note
Optical Power	P_{OP}	-3	2	dBm	-
Average Launch Power Of Off Tx	P_{Off}	-	-45	dBm	-
Extinction Ratio	ER	10	-	dB	-
Eye Mask	-	SONET/SDH compliant			-
Optical Jitter Generation	J_{gen}	-	0.002	UI	-
Optical Rise Time	t_r	-	500	ps	1
Optical Fall Time	t_f	-	500	ps	1
Mean Wavelength	λ	1480	1580	nm	-
Spectral Width (-20 dB Width)	$\Delta\lambda$	-	1	nm	-
Side Mode Suppression Ration	SMSR	-	30	dB	-
Dispersion Penalty (at 80 Km)	-	-	1	dB	-
Relative Intensity Noise	RIN	-	-120	dB/Hz	-

Notes: 1. 20%-80% values

Receiver Specifications, Optical

Parameter	Symbol	Minimum	Maximum	Unit	Note
Receive Power Low	$R_{sens,low}$	-	-28	dBm	1
Receive Power High	$R_{sens,high}$	-8	-	dBm	-
Damage Threshold for Receiver	$P_{in,damage}$	0	-	dBm	-
Wavelength	λ	1480	1580	nm	2
LOS Assert	LOS_A	-45	-	dBm	-
LOS De-Assert	LOS_D	-	-28	dBm	-
LOS Hysteresis	-	0.5	-	dB	-

Notes: 1. 10^{-12} at nominal wavelength
2. Operational over 1200 to 1625 nm range

Monitoring Specifications

Parameter	Range	Accuracy	Unit	Calibration	Formula
Temperature	-5 to 70 °C	± 3	°C	Internal	$T_c(C) = T_{ad}(16 \text{ bit signed twos complement})/256$
Temperature (TH Models)	-40 to 85 °C	± 3	°C	Internal	$T_c(C) = T_{ad}(16 \text{ bit signed twos complement})/256$
Voltage	0 to V_{CC}	± 0.1	V	Internal	$V(\text{Volts}) = V_{ad}(16 \text{ bit unsigned integer}) * 0.1$
Bias Current	0 to 120	± 5	mA	External	$I(\text{mA}) = I_{slope} * I_{ad}(16 \text{ bit unsigned integer}) + I_{offset}$
Tx Power	-3 to 2	± 3	dBm	External	$TX_PWR(\mu W) = TX_PWR_{slope} * TX_PWR_{ad}(16 \text{ bit unsigned integer}) + TX_PWR_{offset}$
Rx Power	-28 to -8	± 3	dBm	External	$RX_PWR(\mu W) = A_0 + A_1 * x + A_2 * x^2 + A_3 * x^3 + A_4 * x^4$

General Operations

Parameter	Symbol	Minimum	Maximum	Unit	Note
Supply Voltage	V_{CC}	3.135	3.465	V	-
Total Current	I_{CC}	-	300	mA	-
Power Supply Noise Rejection	PSR	100	-	mV _{p-p}	1
Operating Case Temperature	T_{op}	-5	70	°C	-
Operating Case Temperature (TH Models)	T_{op}	-40	85	°C	-
Storage Temperature	T_{st}	-40	85	°C	-
Data Rate OC-12/STM-4	DR	-	622	Mbps	-

Notes: 1. 20 Hz to 155 MHz

Datasheet

Transmitter Specifications, Electrical

Parameter	Symbol	Minimum	Maximum	Unit	Note
Input Differential Impedence	R_{in}	80	120	Ω	-
PECL Single Ended Data Input Swing	$V_{in,p-p}$	250	1200	mV	-
TxFault_Fault	V_{fault}	2	V_{cc}	V	-
TxFault_Normal	V_{normal}	V_{ee}	$V_{ee}+0.5$	V	-
TxDisable_Disable	V_d	2	V_{cc}	V	-
TxDisable_Enable	V_{en}	V_{ee}	$V_{ee}+0.8$	V	-

Electrical Output

Parameter	Symbol	Minimum	Maximum	Unit	Note
PECL Single Ended Data Output Swing	$V_{out,p-p}$	185	800	mV	-
Data Output Rise Time	t_r	-	500	ps	-
Data Output Fall Time	t_f	-	500	ps	-

Timing and Electrical

Parameter	Symbol	Minimum	Maximum	Unit	Note
Tx Disable Negate Time	t_{on}	-	1	ms	-
Tx Disable Assert Time	t_{off}	-	10	μs	-
Time To Initialize, Including Reset Of Tx Fault	t_{init}	-	300	ms	-
Tx Fault Assert Time	t_{fault}	-	100	μs	-
Tx Disable To Reset	t_{reset}	10	-	μs	-
Los Assert Time	$t_{loss_{on}}$	-	100	μs	-
Los De-assert Time	$t_{loss_{off}}$	-	100	μs	-
Serial ID Clock Rate	f_{serial_clock}	-	100	KHz	-
RX_LOS Voltage (High)	-	2	-	V	-
RX_LOS Voltage (Low)	-	-	0.8	V	-
LOS Output Voltage-Fault	$V_{LOS_{fault}}$	2	V_{cc}	V	-
LOS Output Voltage-Normal	$V_{LOS_{normal}}$	V_{ee}	$V_{ee}+0.5$	V	-
MOD_DEF (0:2)-High	V_h	2	V_{cc}	V	-
MOD_DEF (0:2)-LOW	V_l	V_{ee}	$V_{ee}+0.5$	V	-

Datasheet

Pin Descriptions		
Pin	Function	Name/Description
1	V _{ee} T	Transmitter Ground
2	Tx_Fault	Open Collector
3	Tx_Disable	Internally Pulled High
4	MOD_DEF(2)	Serial Data Input
5	MOD_DEF(1)	Serial Clock Input
6	MOD_DEF(0)	Internally Grounded
7	NC	Not Connected
8	LOS	Open Collector
9	V _{ee} R	Receiver Ground
10	V _{ee} R	Receiver Ground
11	V _{ee} R	Receiver Ground
12	RXD-	Receiver Data Negative
13	RXD+	Receiver Data Positive
14	V _{ee} R	Receiver Ground
15	V _{cc} R	Receiver Power
16	V _{cc} T	Transmitter Power
17	V _{ee} T	Transmitter Ground
18	TXD+	Transmitter Data Positive
19	TXD-	Transmitter Data Negative
20	V _{ee} T	Transmitter Ground

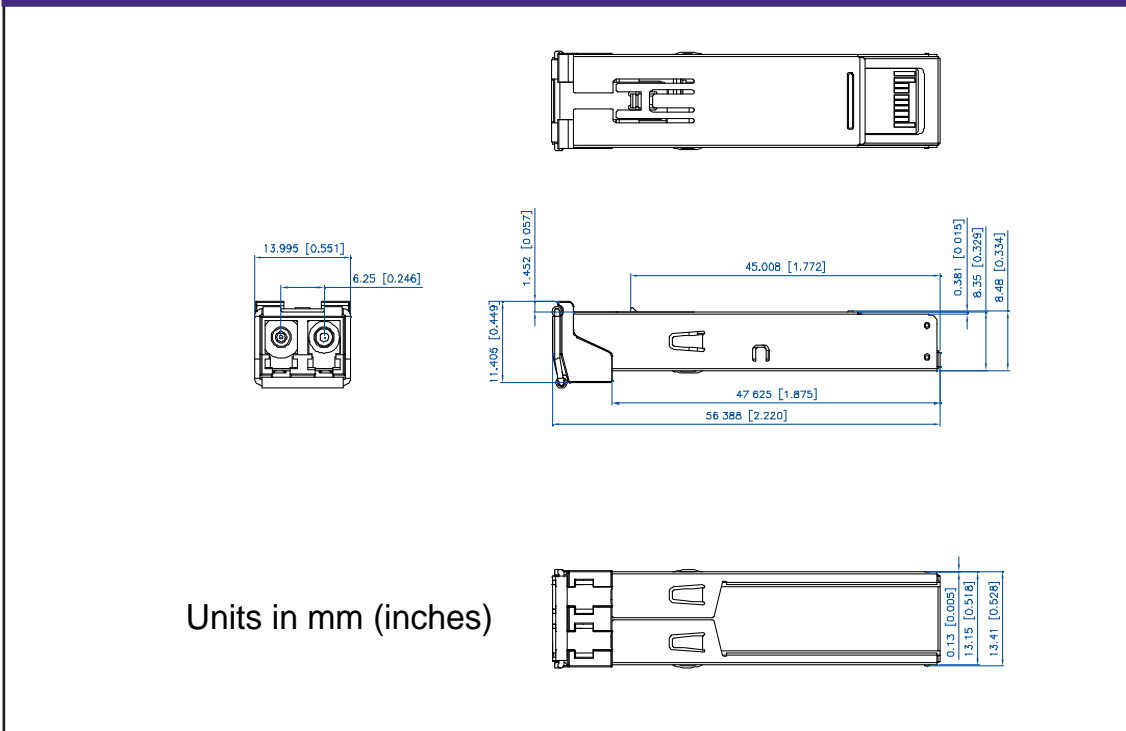
Mechanical Dimensions



Datasheet

Ordering Information

Model	Description	Data Rate (Mbps)	Connector	Bail Latch Color	Digital Diagnostics	Maximum Distance Range (km)
SFP-O12D-LR2	SDH STM-4, SONET OC-12 SFP Transceiver	622	Duplex LC	White	Yes	20 - 80
SFP-O12D-LR2TH	SDH STM-4, SONET OC-12 SFP Transceiver, <i>Temperature Hardened</i>	622	Duplex LC	White	Yes	20 - 80

Regulatory and Industry Compliances

Class 1 Laser Product, complies with EN 60825-1 and 21 CFR 1040.10 except for deviations pursuant to Laser Notice No. 50. dated June 24, 2007
MSA SFF-8074i; Digital Diagnostic SFF-8472

Certified by one or more of the following agencies: TÜV, UL, CSA

RoHS Directive; China RoHS; California RoHS Law, REACH Directive SVHC; WEEE Directive

The Quality Management System is certified to ISO 9001 by QMI-SAI Global

The Environmental Management System is in compliance with ISO 14001

Warnings

Handling Precautions: This device is susceptible to damage as a result of electrostatic discharge (ESD). A static free environment is highly recommended. Follow guidelines according to proper ESD procedures.

Laser Safety: Radiation emitted by laser devices can be dangerous to human eyes. Avoid eye exposure to direct or indirect radiation.

MRV has more than 50 offices throughout the world. Addresses, phone numbers and fax numbers are listed at www.mrv.com.
Please e-mail us at info@mrv.com or call us for assistance.

MRV Los Angeles
20415 Nordhoff Street
Chatsworth, CA 91311
800-338-5316
818-773-0900

MRV Boston
300 Apollo Drive
Chelmsford, MA 01824
800-338-5316
978-674-6800

MRV International
Business Park Moerfelden
Waldeckerstrasse 13
64546 Moerfelden-Walldorf
Germany
Tel. (49) 6105/2070
Fax (49) 6105/207-100

All statements, technical information, and recommendations related to the products herein are based upon information believed to be reliable or accurate. However, the accuracy or completeness thereof is not guaranteed, and no responsibility is assumed for any inaccuracies. Please contact MRV Communications for more information. MRV Communications and the MRV Communications logo are trademarks of MRV Communications, Inc. Other trademarks are the property of their respective holders.