

Datasheet

155 Mbps Multi-Mode 2 km SFP Transceivers

SFP-O3-M



Highlights

- SFP transceiver
- Data Rates: 155 Mbps
- Protocols:
 - SDH STM-1
 - SONET OC-3
- Multi-mode fiber
- 1310 nm
- 0 to 2 km (on 62.5/125 μ m MMF)
- Duplex LC connector
- Hot-swap

Overview

Small Form-Factor Pluggable (SFP) interfaces from MRV Communications provide flexible high speed links in a small industry-standard package. They deliver the deployment options and inventory control that network administrators demand for growing networks.

SFPs are designed to Multi-Source Agreement (MSA) standards to ensure network equipment compatibility. They are a perfect addition to MRV's extensive lines of networking equipment.

Visit the MRV website at www.mrv.com or contact your nearest authorized MRV Communications dealer for more information.

Specifications Overview

Data Rate	155 Mbps
Tx Wavelength	1310 nm
Tx Power (Minimum)	-20 dBm
Tx Disable	Yes
Rx Wavelength Range	1260 - 1360 nm
Rx Sensitivity	-30 dBm
Rx Saturation	-8 dBm
Rx Damage Threshold	0 dBm
Operating Temperature Range	-5 to 70 °C
Power Consumption	1 Watt

Datasheet

Optical Transmitter Specifications

Parameter	Symbol	Minimum	Maximum	Unit	Note
Optical Power	P_{op}	-20	-14	dBm	-
Average Launch Power (Tx:Off)	P_{off}	-	-45	dBm	-
Extinction Ratio	ER	10	-	dB	-
Eye Mask	-	SONET/SDH compliant			-
Optical Rise Time	t_r	-	2	ns	1
Optical Fall Time	t_f	-	2	ns	1
Mean Wavelength	λ	1270	1380	nm	-
Spectral Width (RMS)	$\Delta\lambda$	-	7.7	nm	-

Notes: 1. 20% - 80% values

Optical Transmitter Specifications

Parameter	Symbol	Minimum	Maximum	Unit	Note
Receive Power	$R_{sens, low/high}$	-30	-8	dBm	1
Receiver Damage Power	$P_{in, damage}$	0	-	dBm	-
Wavelength	λ	1260	1360	nm	2
LOS Assert	LOS_A	-45	-	dBm	-
LOS De-Assert	LOS_D	-	-30	dBm	-
LOS Hysteresis	Hys	0.5	-	dB	-

Notes: 1. Measured with a PRBS 2²³-1, BER 10⁻¹⁰
2. Operational over 1200 to 1625nm range

General Operations

Parameter	Symbol	Minimum	Maximum	Unit	Note
Power Supply Voltage	V_{cc}	3.135	3.465	V	-
Power Supply Current	I_{cc}	-	300	mA	-
Power Supply Noise Rejection	PSR	100	-	mV _{p-p}	1
Operating Case Temperature	T_{op}	-5	70	°C	-
Storage Temperature	T_{st}	-40	85	°C	-
Data Rate OC-3/STM-1	DR	-	155.52	Mbps	-

Notes: 1. 20 Hz to 155 MHz

Electrical Transmitter Specifications

Parameter	Symbol	Minimum	Maximum	Unit	Note
Input Differential Impedance	R_{in}	80	120	Ω	-
PECL Single-Ended Data Input Swing	$V_{in, p-p}$	250	1200	mV	-
TxFault_Fault	V_{fault}	2	V_{cc}	V	-
TxFault_Normal	V_{normal}	V_{ee}	$V_{ee} + 0.5$	V	-
TxDisable_Disable	V_d	2	V_{cc}	V	-
TxDisable_Enable	V_{en}	V_{ee}	$V_{ee} + 0.8$	V	-

Datasheet

Electrical Receiver Specifications

Parameter	Symbol	Minimum	Maximum	Unit	Note
PECL Single-Ended Data Output Swing	$V_{out, p-p}$	185	800	mV	-
Data Output Rise Time	t_r	-	2	ns	-
Data Output Fall Time	t_f	-	2	ns	-

Timing and Electrical

Parameter	Symbol	Minimum	Maximum	Unit	Note
Tx Disable Negate Time	t_{on}	-	1	ms	-
Tx Disable Assert Time	t_{off}	-	10	μ s	-
Time to Initialize, Including Reset of Tx Fault	t_{init}	-	300	ms	-
Tx Fault Assert Time	t_{fault}	-	100	μ s	-
Tx Disable to Reset	t_{reset}	10	-	μ s	-
LOS Assert Time	$t_{loss_{on}}$	-	100	μ s	-
LOS De-Assert Time	$t_{loss_{off}}$	-	100	μ s	-
Serial ID Clock Rate	f_{serial_clock}	-	100	KHz	-
RX_LOS Voltage (High)	-	2	-	V	-
RX_LOS Voltage (Low)	-	-	0.8	V	-
LOS Output Voltage-Fault	$V_{LOS\ fault}$	2	V_{cc}	V	-
LOS Output Voltage-Normal	$V_{LOS\ normal}$	V_{ee}	$V_{ee} + 0.5$	V	-
MOD_DEF (0:2)-High	V_h	2	V_{cc}	V	-
MOD_DEF (0:2)-LOW	V_l	V_{ee}	$V_{ee} + 0.5$	V	-

Pin	Function	Notes
1	V_{eeT}	TX Ground
2	TX_FAULT	Open Collector
3	TX_DISABLE	Internally Pulled High
4	MOD_DEF2	Serial Data Input
5	MOD_DEF1	Serial Clock Input
6	MOD_DEF0	Internally Grounded
7	NC	Not Connected
8	LOS	Open Collector
9	V_{eeR}	RX Ground
10	V_{eeR}	RX Ground
11	V_{eeR}	RX Ground
12	RXD-	RX Data Negative
13	RXD+	RX Data Positive
14	V_{eeR}	RX Ground
15	V_{ccR}	RX Power
16	V_{ccT}	TX Power
17	V_{eeT}	TX Ground
18	TXD+	TX Data Positive
19	TXD-	TX Data Negative
20	V_{eeT}	TX Ground

Datasheet

Mechanical Dimensions

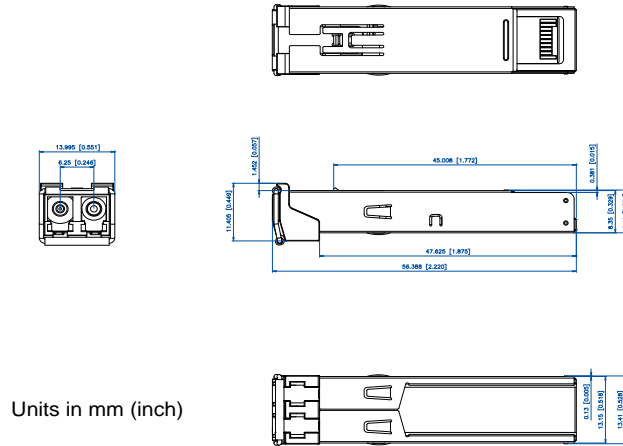

Ordering Information

Model	Description	Data Rate (Mbps)	Connector	Bail Latch Color	Digital Diagnostics	Maximum Distance Range (km)
SFP-O3-M	SDH STM-1, SONET OC-3 Multi-Mode SFP Transceiver	155	Duplex LC	Grey	No	0 - 2

Regulatory and Industry Compliances

Class 1 Laser Product, complies with EN 60825-1 and 21 CFR 1040.10 except for deviations pursuant to Laser Notice No. 50, dated June 24, 2007

MSA SFF-8074i; ANSI-T1.105.06 SR-0; Telcordia GR-468

Certified by one or more of the following agencies: TÜV, UL, CSA

RoHS Directive; China RoHS; California RoHS Law, REACH Directive SVHC; WEEE Directive

The Quality Management System is certified to ISO 9001 by QMI-SAI Global

The Environmental Management System is in compliance with ISO 14001

Warnings

Handling Precautions: This device is susceptible to damage as a result of electrostatic discharge (ESD). A static free environment is highly recommended. Follow guidelines according to proper ESD procedures.

Laser Safety: Radiation emitted by laser devices can be dangerous to human eyes. Avoid eye exposure to direct or indirect radiation.

MRV has more than 50 offices throughout the world. Addresses, phone numbers and fax numbers are listed at www.mrv.com. Please e-mail us at info@mrv.com or call us for assistance.

MRV Los Angeles
20415 Nordhoff Street
Chatsworth, CA 91311
800-338-5316
818-773-0900

MRV Boston
300 Apollo Drive
Chelmsford, MA 01824
800-338-5316
978-674-6800

MRV International
Business Park Moerfelden
Waldeckerstrasse 13
64546 Moerfelden-Walldorf
Germany
Tel. (49) 6105/2070
Fax (49) 6105/207-100

All statements, technical information and recommendations related to the products herein are based upon information believed to be reliable or accurate. However, the accuracy or completeness thereof is not guaranteed, and no responsibility is assumed for any inaccuracies. Please contact MRV Communications for more information. MRV Communications and the MRV Communications logo are trademarks of MRV Communications, Inc. Other trademarks are the property of their respective holders.