

Datasheet

4 Gbps Multi-Rate Single-Mode SFP Transceiver

SFP-TGD-SR4



Highlights

- SFP transceiver
- Data Rates: 1.0625 to 4.25 Gbps
- Protocols:
 - 1 Gigabit Ethernet
 - 1/2/4 Gbps Fibre Channel
- Single-mode fiber
- Dual fiber, bi-directional
- 1310 nm
- 0 to 10 km range at 2.125 Gbps or less
- 0 to 4 km range at 4.25 Gbps
- Duplex LC connector
- Digital Diagnostics (SFF-8472)
- Hot-swap

Overview

Small Form-Factor Pluggable (SFP) interfaces from MRV Communications provide flexible high speed links in a small industry standard package. They deliver the deployment options and inventory control that network administrators demand for growing networks.

SFPs are designed to Multi-Source Agreement (MSA) standards to ensure network equipment compatibility. They are a perfect addition to MRV's extensive lines of networking equipment.

Visit the MRV website at www.mrv.com or contact your nearest authorized MRV Communications dealer for more information.

Specifications Overview

Data Rate	1.0625 to 4.25 Gbps
Tx Wavelength	1310 nm
Tx Power (Minimum)	-10 dBm
Tx Extinction Ratio	9 dBm
Tx Disable	Yes
Rx Wavelength	1260 to 1600 nm
Rx Sensitivity @ 4.25 Gbps	-18 dBm
Rx Saturation	0 dBm
Operating Temperature Range	-5 to 70 °C
Power Consumption	1 Watt

Datasheet

Optical Specifications

Parameter	Symbol	Minimum	Maximum	Unit	Note
Transmitter					
Output Optical Power	P_{OUT}	-10	-3	dBm	1
Optical Wavelength	λ	1260	1350	nm	2
Spectral Width	σ	-	Note 2	-	2
Optical Modulation Amplitude	OMA	190	-	μ W	2,3
Optical Modulation Amplitude \leq 2.125 Gbps	OMA	174	-	μ W	2,3
Optical Rise/Fall Time @ 4.25 Gbps	t_r, t_f	-	90	ps	4
Optical Rise/Fall Time \leq 2.125 Gbps	t_r, t_f	-	160	ps	4
RIN	-	-	-120	dB/Hz	-
Deterministic Jitter Contribution @ 4.25 Gbps	TX Δ DJ	-	28.5	ps	5
Total Jitter Contribution @ 4.25 Gbps	TX Δ TJ	-	59.8	ps	-
Deterministic Jitter Contribution \leq 2.125 Gbps	TX Δ DJ	-	56.5	ps	5
Total Jitter Contribution \leq 2.125 Gbps	TX Δ TJ	-	119	ps	-
Optical Extinction Ratio @ 1.25 Gbps	ER	9	-	dB	6
Receiver					
Sensitivity @ 4.25 Gbps	R_{SENSr}	-	-18 (0.029)	dBm (mW)	6, 7
Sensitivity @ 2.125 Gbps	R_{SENS2}	-	-21 (0.015)	dBm (mW)	6, 7
Sensitivity @ 1.06 Gbps	R_{SENS1}	-	-22 (0.015)	dBm (mW)	6, 7
Sensitivity @ 1.25 Gbps	R_{SENS1}	-	-22	dBm	8
Stressed Rx Sensitivity @ 1.25 Gbps	-	-	-14.5	dBm	-
Overload	RX _{MAX}	-	0	dBm	-
Electrical 3 dB cutoff frequency	-	-	1500	MHz	-
Electrical 3 dB cutoff frequency	-	-	2500	MHz	-
Optical Center Wavelength	λ_C	1260	1600	nm	-
Return Loss	-	12	-	dB	-
LOS De-Assert	LOS _D	-	-19	dBm	-
LOS Assert	LOS _A	-30	-	dBm	-
LOS Hysteresis	-	0.5	-	dB	-

- Notes:**
- Class 1 Laser Safety per FDA/CDRH and EN (IEC) 60825 regulations.
 - Also specified to meet curves in FC-PI-2 10.0 Figures 18, 19, and 21, which allow trade-off between wavelength, spectral width and OMA.
 - Equivalent extinction ratio specification for Fibre Channel. Allows smaller ER at higher average power.
 - Unfiltered, 20-80%.
 - Measured with DJ-free data input signal. In actual application, output DJ will be the sum of input DJ and DJ.
 - Measured with conformance signals defined in FC-PI-2 10.0 specifications. Value in OMA. Measured with PRBS 2⁷-1 at 10⁻¹² BER.
 - Measured with conformance signals defined in FC-PI-2 10.0 specifications. Represents sensitivity based on OMA spec, as corrected to incoming Extinction Ratio of 13 dB (for example, at 5.75dB incoming extinction ratio, an OMA of 0.029 mW corresponds to -16 dBm sensitivity). Measured with PRBS 2⁷-1 at 10⁻¹² BER
 - Measured with PRBS 2⁷-1 at 10⁻¹² BER

Absolute Maximum Ratings

Parameter	Symbol	Minimum	Maximum	Unit	Note
Maximum Supply Voltage	V_{CC}	-0.5	4.2	V	-
Case Operating Temperature	T_A	-40	85	°C	-
Storage Temperature	T_S	-40	85	°C	-
Relative Humidity (Non-Condensing)	RH	0	85	%	-

Datasheet

General Specifications

Parameter	Symbol	Minimum	Maximum	Unit	Note
Data Rate	BR	1062	4250	Mbps	1
Bit Error Rate	BER	-	10 ⁻¹²	-	2
Max. Supported Link Length on 9/125 µm SMF @ 4G Fibre Channel	L _{MAX1}	-	4	km	3
Max. Supported Link Length on 9/125 µm SMF @ 1G and 2G Fibre Channel	L _{MAX2}	-	10	km	3
Max. Supported Link Length on 9/125 µm SMF @ Gigabit Ethernet	L _{MAX3}	-	10	km	3

- Notes:**
1. Gigabit Ethernet and 1G/2G/4G Fibre Channel compliant.
 2. Tested with a PRBS 2⁷-1 test pattern.
 3. Distances are based on FC-PI-2 10.0 and IEEE 802.3 standards.

Electrical Specifications

Parameter	Symbol	Minimum	Maximum	Unit	Note
Supply Voltage	V _{CC}	3.00	3.60	V	-
Supply Current	I _{CC}	-	300	mA	-
Transmitter					
Input Differential Impedance	R _{in}	80	120	Ω	1
Single Ended Data Input Swing	V _{in} , pp	250	1200	mV	-
Transmit Disable Voltage	V _D	V _{CC} - 1.3	V _{CC}	V	-
Transmit Enable Voltage	V _{EN}	V _{ee}	V _{ee} + 0.8	V	2
Transmit Disable Assert Time	-	-	10	us	-
Receiver					
Single Ended Data Output Swing	V _{out} , pp	285	800	mV	3
Data Output Rise/Fall Time ≤ 2.125 Gbps	t _r , t _f	-	175	ps	4
Data Output Rise/Fall Time @ 4.25 Gbps	t _r , t _f	-	120	ps	4
LOS Fault	V _{LOS fault}	V _{CC} - 0.5	V _{CCHOST}	V	5
LOS Normal	V _{LOS norm}	V _{ee}	V _{ee} + 0.5	V	5
Power Supply Rejection	PSR	100	-	mVpp	6
Deterministic Jitter Contribution ≤ 2.125 Gbps	RX Δ DJ	-	51.7	ps	7, 8
Total Jitter Contribution ≤ 2.125 Gbps	RX Δ TJ	-	122.4	ps	8
Deterministic Jitter Contribution @ 4.25 Gbps	RX Δ DJ	-	25.9	ps	7, 9
Total Jitter Contribution @ 4.25 Gbps	RX Δ TJ	-	61.2	ps	9

- Notes:**
1. AC coupled.
 2. Or open circuit.
 3. Into 100 ohm differential termination.
 4. 20 – 80 %
 5. LOS is LVTTTL. Logic 0 indicates normal operation; logic 1 indicates no signal detected.
 6. All transceiver specifications are compliant with a power supply sinusoidal modulation of 20 Hz to 1.5 MHz up to specified value applied through the power supply filtering network shown on page 23 of the Small Form-factor Pluggable (SFP) Transceiver MultiSource Agreement (MSA) 1, September 14, 2000.
 7. Measured with DJ-free data input signal. In actual application, output DJ will be the sum of input DJ and DJ.
 8. As measured at 0.022 mW OMA.
 9. As measured at 0.048 mW OMA.

Datasheet

Pin Descriptions

Pin	Function	Name/Description	Note
1	V _{EET}	Transmitter Ground (Common with Receiver Ground)	1
2	T _{FAULT}	Transmitter Fault. Not Supported.	-
3	T _{DIS}	Transmitter Disable. Laser Output Disabled on High or Open.	2
4	MOD_DEF(2)	Module Definition 2. Data Line for Serial ID.	3
5	MOD_DEF(1)	Module Definition 1. Data Line for Serial ID.	3
6	MOD_DEF(0)	Module Definition 1. Grounded Within the Module.	3
7	NC	Not Connected	-
8	LOS	Loss of Signal Indication. Logic 0 Indicates Normal Operation.	4
9	V _{EER}	Receiver Ground (Common with Transmitter Ground)	1
10	V _{EER}	Receiver Ground (Common with Transmitter Ground)	1
11	V _{EER}	Receiver Ground (Common with Transmitter Ground)	1
12	RD-	Receiver Inverted DATA Out. AC Coupled.	-
13	RD+	Receiver Non-Inverted DATA Out. AC Coupled.	-
14	V _{EER}	Receiver Ground (Common with Transmitter Ground)	1
15	V _{CCR}	Receiver Power Supply	-
16	V _{CCT}	Transmitter Power Supply	-
17	V _{EET}	Receiver Ground (Common with Transmitter Ground)	1
18	TD+	Transmitter Non-Inverted DATA In. AC Coupled.	-
19	TD-	Transmitter Inverted DATA In. AC Coupled.	-
20	V _{EET}	Receiver Ground (Common with Transmitter Ground)	1

- Notes:**
1. Circuit ground is internally isolated from chassis ground.
 2. Laser output disabled on TDIS >2.0V or open, enabled on TDIS <0.8V.
 3. Should be pulled up with 4.7k - 10 kohms on host board to a voltage between 2.0V and 3.6V. MOD_DEF(0) pulls line low to indicate module is plugged in.
 4. LOS is open collector output. Should be pulled up with 4.7k – 10 kohms on host board to a voltage between 2.0V and 3.6V. Logic 0 indicates normal operation; logic 1 indicates loss of signal.

Diagram of Host Board Connector Block Pin Numbers and Names

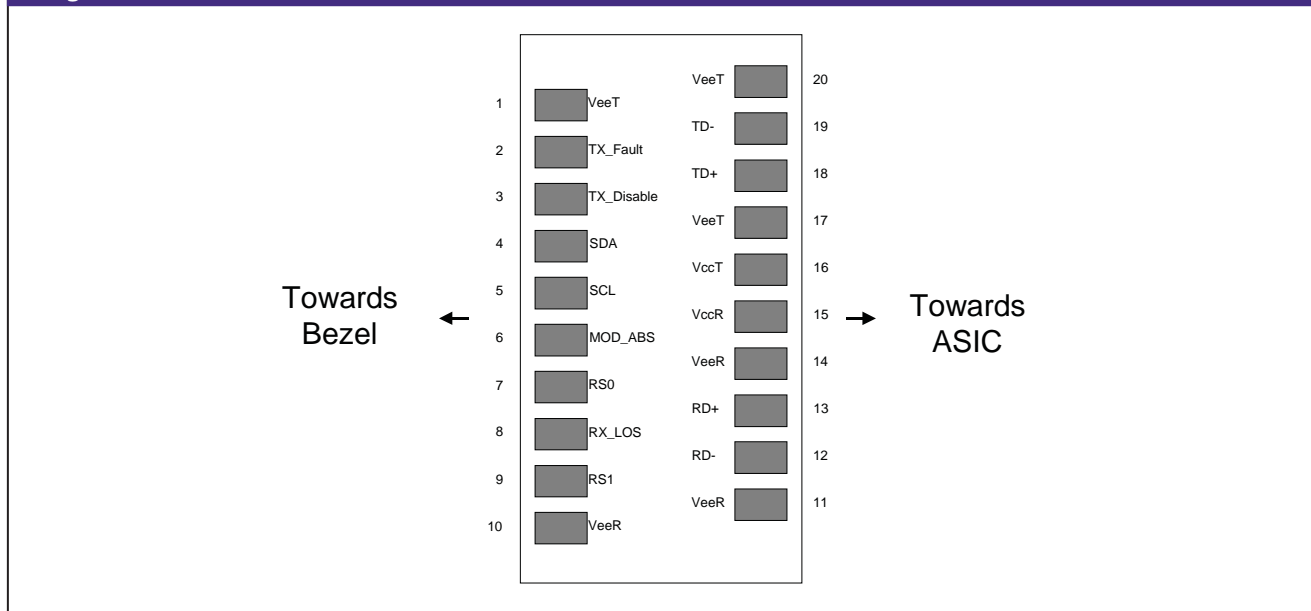

Datasheet

Mechanical Dimensions

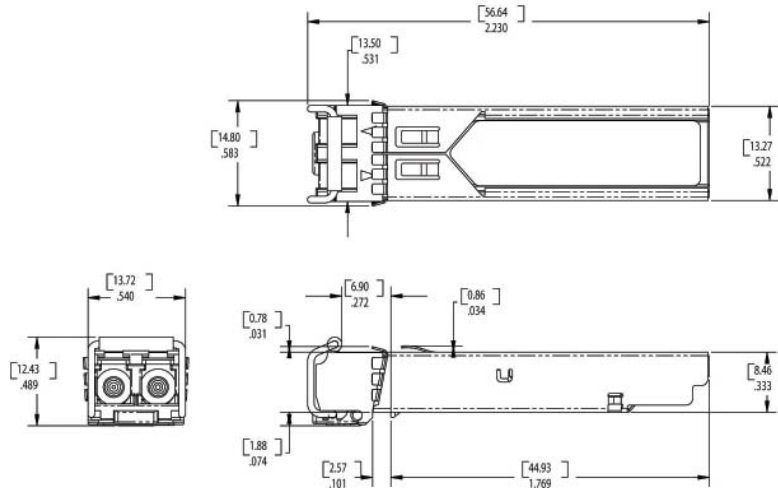

Ordering Information

Model	Description	Data Rate (Gbps)	Wavelength (nm)	Connector	Bail Latch Color	Max. Link Length (km)
SFP-TGD-SR4	1/2/4 Gbps Fibre Channel and 1 Gigabit Ethernet SFP Transceiver	1.0625 - 4.250	1310	Duplex LC	Blue	10

Regulatory and Industry Compliances

Class 1 Laser Product, complies with EN 60825-1 and 21 CFR 1040.10 except for deviations pursuant to Laser Notice No. 50. dated June 24, 2007
 MSA SFF-8074i; Digital Diagnostic SFF-8472;
 Certified by one or more of the following agencies: TÜV, UL, CSA
 RoHS Directive; China RoHS; California RoHS Law, REACH Directive SVHC; WEEE Directive
 The Quality Management System is certified to ISO 9001 by QMI-SAI Global
 The Environmental Management System is in compliance with ISO 14001

Warnings

Handling Precautions: This device is susceptible to damage as a result of electrostatic discharge (ESD). A static free environment is highly recommended. Follow guidelines according to proper ESD procedures.

Laser Safety: Radiation emitted by laser devices can be dangerous to human eyes. Avoid eye exposure to direct or indirect radiation.

MRV has more than 50 offices throughout the world. Addresses, phone numbers and fax numbers are listed at www.mrv.com. Please e-mail us at info@mrv.com or call us for assistance.

MRV Los Angeles
 20415 Nordhoff Street
 Chatsworth, CA 91311
 800-338-5316
 818-773-0900

MRV Boston
 300 Apollo Drive
 Chelmsford, MA 01824
 800-338-5316
 978-674-6800

MRV International
 Business Park Moerfelden
 Waldeckerstrasse 13
 64546 Moerfelden-Walldorf
 Germany
 Tel. (49) 6105/2070
 Fax (49) 6105/207-100

All statements, technical information, and recommendations related to the products herein are based upon information believed to be reliable or accurate. However, the accuracy or completeness thereof is not guaranteed, and no responsibility is assumed for any inaccuracies. Please contact MRV Communications for more information. MRV Communications and the MRV Communications logo are trademarks of MRV Communications, Inc. Other trademarks are the property of their respective holders.