

Datasheet

Multi-Rate Digital Video SFP

SFP-TMDV3G



Highlights

- Enables digital video signals over fiber optic links
- Wide protocol support with 270 Mbps to 2.97 Gbps data rates (output data rate equals input data rate)
- 3G-SDI
 - SMPTE 424M (2.97 and 2.97/1.001 Gbps)
- HD-SDI
 - SMPTE 292M (1.4835/1.485 Gbps)
- SDI
 - SMPTE 259M-C (270 Mbps)
- DVB ASI (270 Mbps)
- 75 ohm coaxial input/output with standard BNC connectors
- Plug-n-Play operation
- SFP MSA (as applicable)

Advantages

- Allows uncompressed digital video component signal transport over any standard optical transport system
- Allows standard optical transceivers (MSA compliance)
- Supports digital video links over fiber optic cabling

Overview

MRV's digital video SFP-TMDV3G is designed to affordably transmit SDI, HD-SDI, 3G-SDI, or DVB digital video component signals over fiber using standard optical transceivers. Compatible with any optical transport system – WDM platforms, optical/electrical cross-connects, etc. – the unidirectional digital video SFPs from MRV open a new world of cost-effective digital video deployment options:

- Link extension over new or existing fiber plant
- Wave division multiplexing (CWDM and DWDM)
- Link redundancy for mission critical applications
- Video distribution and multicasting
- ... and more!

SDI HD-SDI, 3G-SDI, and DVB are the basic standards used to transport serial component digital video data on single coaxial cable. Coaxial cable limits the link range to 350 meters between the signal source and destination for standard definition video, 140 meters for high definition, and 100 meters for 3G video. These distances are designed for intra-building or small campus networks.

However, the advent of geographically dispersed studio campuses requires more digital video data to travel across the sophisticated optical infrastructure of the metro and inter-metro network. Links of 100 kilometers or more and the use of WDM technology are increasingly common. MRV's digital video SFPs easily merge digital video traffic onto these optical transport networks.

Datasheet

MRV's digital video SFPs are designed to carry digital video signals (see specific protocols in the datasheet). Pathological signals (long strings of sequential zeros or sequential ones) require additional processing.

The SFP-TMDV3G-RX is a coaxial receiver designed to support digital video signals as defined by the SDI, HD-SDI, 3G-SDI, or DVB standards. It recognizes the digital video stream and generates a data signal that is compatible with these optical transport systems supporting the digital video data rates.

The signal passes through the receiving module to an MSA-standard optical transceiver that transports it over a fiber optic link. At the far end of the optical link, the signal is received by another MSA-standard optical transceiver and passed to the SFP-TMDV3G-TX.

The SFP-TMDV3G-TX, in turn, processes the data signal and sends the resulting digital video stream to the receiving digital video device, once again over a coaxial cable.

Contact your nearest authorized MRV representative and visit our website at www.mrv.com for more information on the complete line of MRV solutions, including pricing and availability.

Application: Digital Video Extension Over Fiber

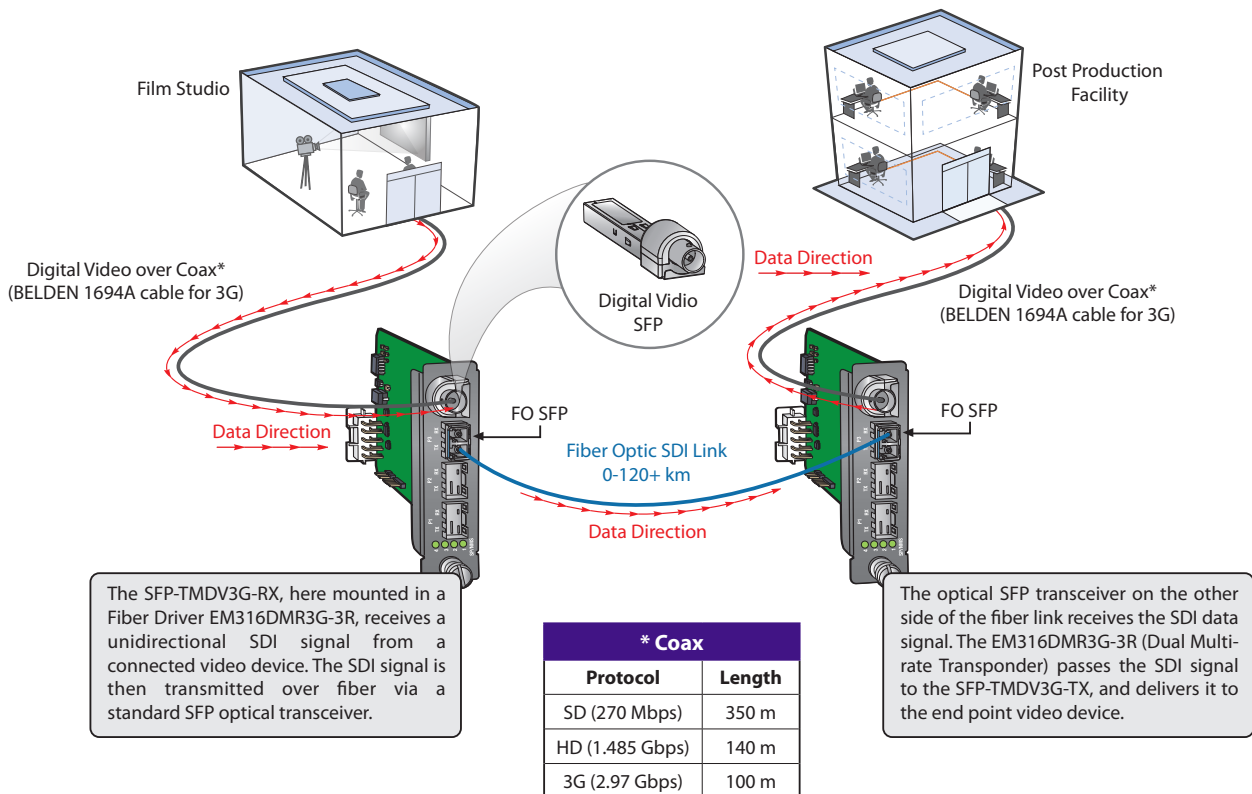

Datasheet

General Specifications	Transmitter	Receiver
Coaxial Interface:		
Input/Output Connector	BNC (x1)	BNC (x1)
Impedance	75 Ohms (output)	75 Ohms (input)
Output Level	800 mV	N/A
SFP Interface	Complies with SFP MSA standard (as applicable)	Complies with SFP MSA standard (as applicable)
Performance:		
CRC/EDH Error Rate	< 10 ⁻⁹	< 10 ⁻⁹
Status and Control Signals:		
RX LOS	N/A	Yes
TX Disable	Yes	N/A
Auto Cable Equalization	N/A	Yes
Temperature Range:		
Operating	-5 to 50° C	-5 to 50° C
Storage	-40 to 85° C	-40 to 85° C
Agency Compliance:		
FCC Part 15, EMC Directive, WEEE Directive, RoHS, China RoHS, SFP MSA (as applicable)		

SFP EDGE CONNECTOR SPECIFICATIONS

Pin #	MSA name	TMDV Coax Receiver	TMDV Coax Transmitter
1	Rx_OPM	Factory use only; leave open	Factory use only; leave open
2	TxFault	Factory use only; leave open	Factory use only; leave open
3	TxDisable	N/A	Mutes Coax output
4	MOD_DEF(2)	I2C SDA signal	I2C SDA signal
5	MOD_DEF(1)	I2C SCL signal	I2C SCL signal
6	MOD_DEF(0)	GRD	GRD
7	Rate Select	Factory use only; leave open	Factory use only; leave open
8	LOS	Signal detected at coax	High Level
9	Tx_I	Factory use only; leave open	Factory use only; leave open
10	Tx_DC	Factory use only; leave open	Factory use only; leave open
11	VeeR	GRD	GRD
12	RD-	Output data to SFP edge connector	Not used
13	RD+	Output data to SFP edge connector	Not used
14	VeeR	GRD	GRD
15	VccR	3.3VDC	3.3VDC
16	VccT	3.3VDC	3.3VDC
17	VeeT	GRD	GRD
18	TD+	Not used	Input data from SFP edge connector
19	TD-	Not used	Input data from SFP edge connector
20	VeeT	GRD	GRD

Datasheet

Electrical Characteristics

TX outputs:

800mV p-p, within 10%

75 ohm driver

Outputs are AC coupled inside the SFP

RX inputs:

125 to 880mv p-p

Driver to be ECL or LVDS

AC coupled inside the SFP

75 ohm nominal load inside the SFP

EEPROM and Interface Details

The following information is available through the interface at the locations indicated.

A0: Can be read by user. Has name of the SFP in it. For instance, 'SFP-TMDV-TX' indicates a transmitter.

MSA Compliance

The MRV video SFPs are MSA compliant for pluggability and format. However, the TMDV modules implement only the small subset of the information described in the MSA that applies to them. This subset of information is described in the "EEPROM and Interface Details" section.

Mechanical Drawing

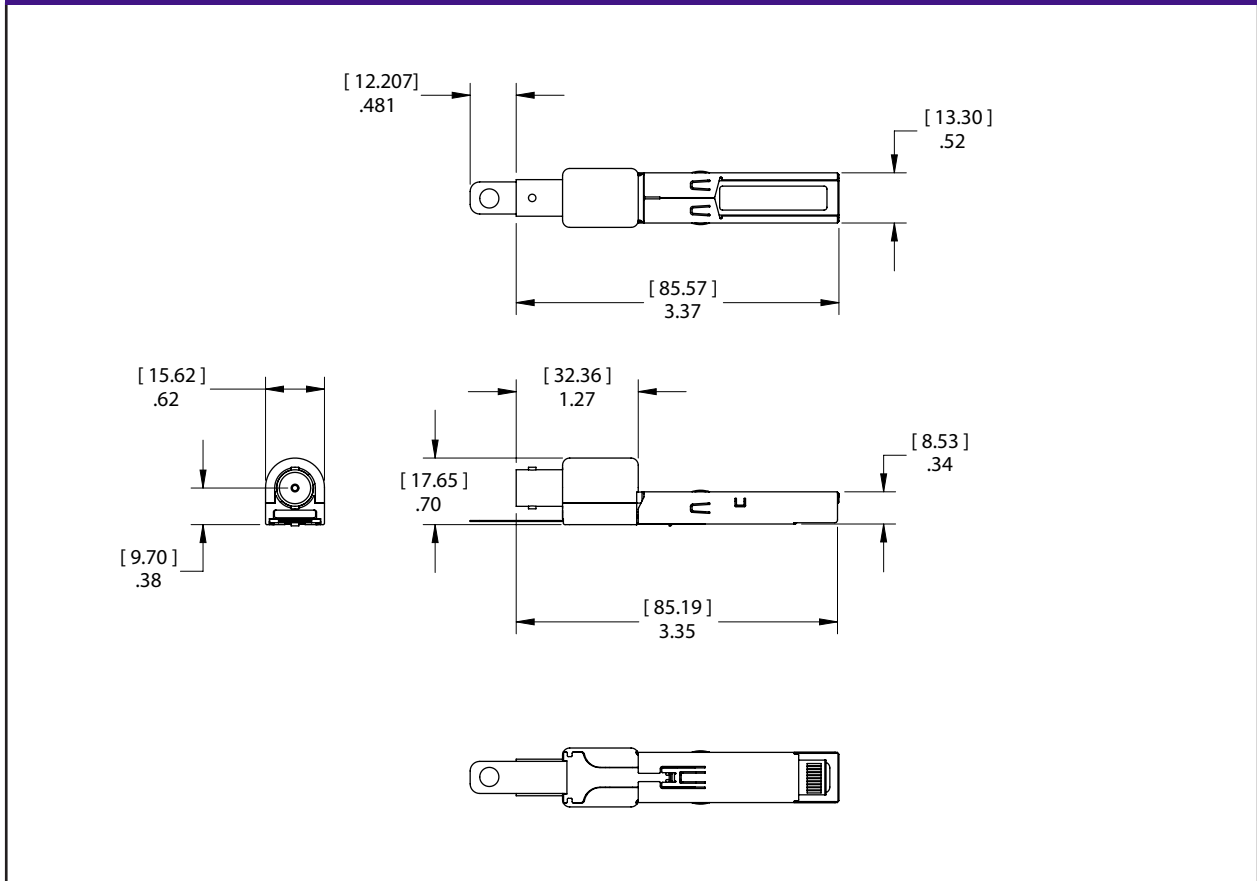

**Datasheet****Ordering Information (use in pairs as shown)**

Model	Function/ Protocol	Supported Data Rate	Connector	Impedance (Ohms)	Output Level (mV)	Max. Coaxial Cable Length (m)*
SFP-TMDV3G-TX	Unidirectional digital video SFP transmitter	270 Mbps -2.97 Gbps	BNC	75	800	350 @270 Mbps 140 @1.485 Gbps 100 @2.97 Gbps
SFP-TMDV3G-RX	Unidirectional digital video SFP receiver	270 Mbps -2.97 Gbps	BNC	75	-	

* Distances may vary based on properties of the transponder, cables, and power supply.

Coax cables must be BELDEN 1694A grade cables rated for 3G applications.

Visit the MRV website or contact an MRV representative for solutions that handle these non-standard signals.

MRV has more than 50 offices throughout the world. Addresses, phone numbers and fax numbers are listed at www.mrv.com.
Please e-mail us at info@mrv.com or call us for assistance.

MRV Los Angeles
20415 Nordhoff Street
Chatsworth, CA 91311
800-338-5316
818-773-0900

MRV Boston
300 Apollo Drive
Chelmsford, MA 01824
800-338-5316
978-674-6800

MRV International
Business Park Moerfelden
Waldeckerstrasse 13
64546 Moerfelden-Walldorf
Germany
Tel. (49) 6105/2070
Fax (49) 6105/207-100

All statements, technical information and recommendations related to the products herein are based upon information believed to be reliable or accurate. However, the accuracy or completeness thereof is not guaranteed, and no responsibility is assumed for any inaccuracies. Please contact MRV Communications for more information. MRV Communications and the MRV Communications logo are trademarks of MRV Communications, Inc. Other trademarks are the property of their respective holders.