

Datasheet

Multi-Rate (10 Gbps) 120 km XFP Transceivers

XFP-10GD-LR12P



Highlights

- XFP transceiver
- Data Rates: 9.953 - 11.318 Gbps
- Protocols:
 - Ethernet (10GBASE and 10GBASE with FEC)
 - Fibre Channel (10G and 10G with FEC)
 - SDH (STM-64)
 - SONET (OC-192, and OC-192 with FEC)
- Single-mode fiber
- Dual fiber, (Tx/Rx)
- 1550 nm
- Electronic Dispersion Compensation (EDC) built into transceiver
- Dispersion tolerance supports:
 - 120 km reach with amplifier
 - 80 km reach without amplifier
- Duplex LC connector
- Digital Diagnostics (SFF-8472)
- XFI and lineside loopback
- Hot-swap

Overview

MRV Communications’ XFP transceivers provide the high speeds and compact dimensions that today’s demanding networks require while delivering the deployment flexibility and inventory control that network administrators demand. Designed to Multi-Source Agreement (MSA) standards for broadest compatibility, they perfectly match MRV’s wide range of optical transport solutions.

Visit the MRV website at www.mrv.com or contact your nearest authorized MRV Communications dealer for more information.

Specifications Overview	
Data Rate	9.953 - 11.318 Gbps
Tx Wavelength	1550 nm
Tx Power (Minimum)	0 dBm
Dispersion Tolerance	2400 ps/nm
Tx Disable	Yes
Rx Wavelength	1528 - 1561 nm
Rx Sensitivity @ 11.3 Gbps	-25 dBm
Rx Saturation	-7 dBm
Operating Temperature Range	-5 to 70°C
Power Consumption (Maximum)	3.5 Watts

* Requires protocol-specific reference clock. See host module datasheet for XFP compatibility/protocol support.

Datasheet

Transmitter Specifications (Optical)

Parameter	Symbol	Min	Max	Unit	Notes
Optical Output Power	OP	0	4	dBm	-
Optical Power Shutdown	PDown	-	-40	nm	-
Extinction Ratio	ER	8	10	dB	-
Optical Output Eye Mask Margin	-	ITU-T G.691; ITU-T G709; 10GE Compliant			-
Side Mode Suppression Ratio	SMSR	40	-	dB	-
Wavelength	L	1530	1565	nm	-
Spectral Width (@ -20 dB)	DL	-	0.3	nm	-
Jitter Transfer Bandwidth	JBW	2	8	MHz	-
Jitter Transfer Peaking	JP	-	0.03	dB	1
Total Jitter Generation	JG-tot	-	0.3	UIpp	2
Chromatic Dispersion Penalty (@ 2400 ps/nm)	DP	-	4	dB	3

- Note:**
1. F < 120 KHz
 2. 20 kHz - 80 MHz
 3. BER = 10^{-12} BER, PRBS $2^{31}-1$

Receiver Specifications (Optical)

Parameter	Symbol	Min	Max	Unit	Notes
B-B Sensitivity (11.3 Gbps)	-	-	-25	dBm	1
Overload	OV	-7	-	dBm	-
Wavelength	L	1528	1561	nm	2
LOS Assert	LOS_A	-35	-	dBm	3
LOS De-assert	LOS_D	-	-30	dBm	4
LOS Hysteresis	LOS_H	0.5	2	dB	-

- Note:**
1. BER = 10^{-12} BER, PRBS $2^{31}-1$
 2. Operational over 1200 - 1625 nm range
 3. BER > 10^{-3}
 4. BER > 10^{-4}

Absolute Maximum Rating

Parameter	Symbol	Min.	Max.	Unit	Notes
Maximum Supply Voltage (1.8 V)	V _{CC2}	0	2	V	-
Maximum Supply Voltage (3.3 V)	V _{CC3}	0	4	V	-
Maximum Supply Voltage (5.0 V)	V _{CC5}	0	6	V	-
Storage Temperature	T _S	-40	85	°C	-
Static Discharge Voltage	-	-	500	V	1

- Note:**
1. HBM Human Body Level: JESD22-A114-B

Datasheet

General Operating Conditions

Parameter	Symbol	Min	Max	Unit	Notes
Supply Voltage (1.8 V)	V _{cc2}	1.7	1.9	V	-
Supply Voltage (3.3 V)	V _{cc3}	3.1	3.5	V	-
Supply Voltage (5.0 V)	V _{cc5}	4.7	5.3	V	-
Supply Current (1.8 V)	I _{cc2}	-	500	mA	-
Supply Current (3.3 V)	I _{cc3}	-	750	mA	-
Supply Current (5.0 V)	I _{cc5}	-	1000	mA	-
Module Total Power Consumption	P _t	-	3.5	W	-
Power Consumption-P_Down Mode	P _{p_d}	-	1.5	W	-
Power Supply Noise Rejection	PSNR	Compliant to Section 2.7.2 of XFP MSA			-
Bit Rate	BR	9.953	11.318	Gbps	-
Operating Case Temperature	T _{op}	-5	70	°C	-
Storage Temperature	T _{st}	-40	85	°C	-

Electrical Specifications and Reference Clock

Parameter	Symbol	Min	Max	Unit	Notes
Differential Data Input Swing	InDD	120	850	mVpp	-
Differential Data Output Swing	OutDD	340	850	mVpp	-
Differential Input Clock Amplitude (p-p)	InCLK	640	1600	mVpp	1

Note: 1. Clock interface according with XFP MSA rev 4.5; frequency range = 155MHz – 177MHz

Module Block Diagram

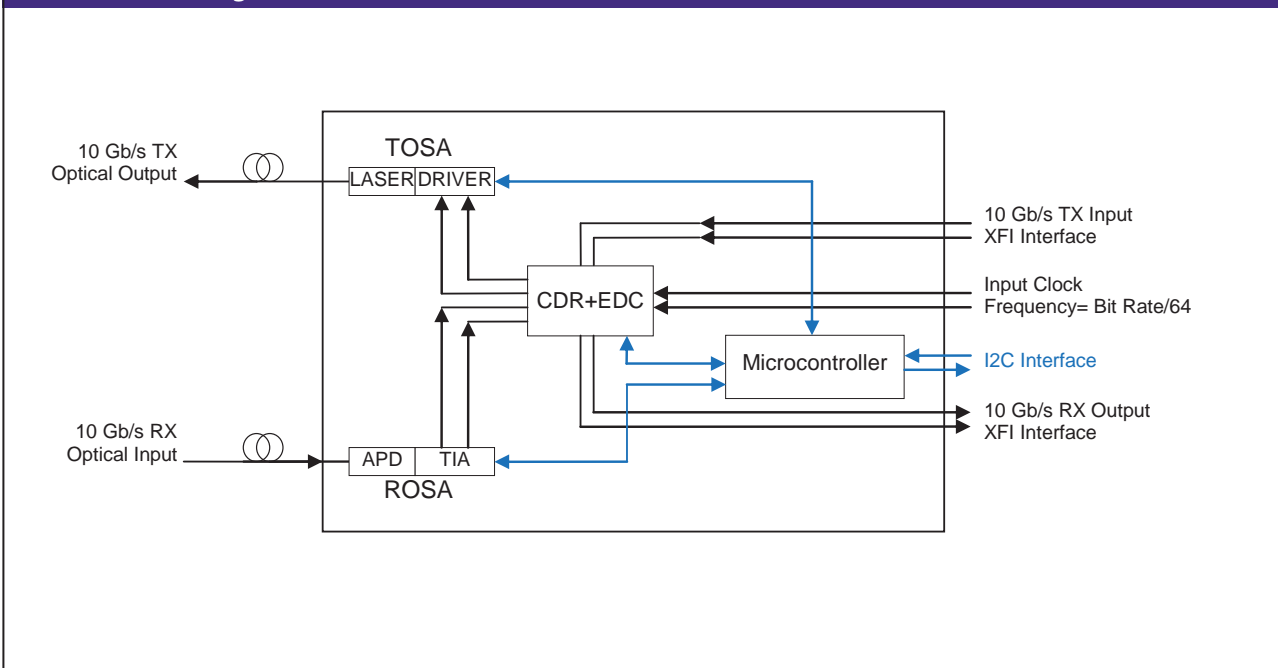

Datasheet

Pin Out Definition

Pin	Logic	Symbol	Name/Description	Note
1	-	GND	Module Ground	1
2	-	VEE5	Optional -5.2V power supply (not used)	-
3	LVTTTL-I	Mod_DeSel	Module De-Select; when held low allows module to respond to 2-wire serial interface	-
4	LVTTTL-O	Interrupt	Interrupt (bar); indicates presence of an important condition which can be read over the 2-wire serial interface	2
5	LVTTTL-I	TX_DIS	Transmitter Disable; turns off transmitter laser output	-
6	-	Vcc5	+5 V Power Supply	-
7	-	GND	Module Ground	1
8	-	Vcc3	+3.3 V Power Supply	-
9	-	Vcc3	+3.3 V Power Supply	-
10	LVTTTL-I/O	SCL	2-Wire Serial Interface Clock	2
11	LVTTTL-I/O	SDA	2-Wire Serial Interface Data Line	2
12	LVTTTL-O	Mod_Abs	Indicates module is not present. Grounded in the module	2
13	LVTTTL-O	Mod_NR	Module Not Ready; indicating module operational fault	2
14	LVTTTL-O	RX_LOS	Receiver Loss of Signal Indicator	2
15	-	GND	Module Ground	1
16	-	GND	Module Ground	1
17	CML-O	RD-	Receiver Inverted Data Output	-
18	CML-O	RD+	Receiver Non-Inverted Data Output	-
19	-	GND	Module Ground	1
20	-	Vcc2	+1.8 V Power Supply	-
21	LVTTTL-I	P_Down/RST	Power Down; When high, requires the module to limit power consumption to 1.5 W or below. 2-wire serial interface must be functional in the low power mode. Reset; the falling edge initiates a complete reset of the module including the 2-wire serial interface, equivalent to a power cycle.	-
22	-	Vcc2	+1.8 V Power Supply	-
23	-	GND	Module Ground	1
24	PECL-I	RefCLK+	Reference Clock Non-Inverted Input, AC coupled on the host board	-
25	PECL-I	RefCLK-	Reference Clock Inverted Input, AC coupled on the host board	-
26	-	GND	Module Ground	1
27	-	GND	Module Ground	1
28	CML-I	TD-	Transmitter Inverted Data Input	-
29	CML-I	TD+	Transmitter Non-Inverted Data Input	-
30	-	GND	Module Ground	1

- Note:**
1. Module ground pins GND are isolated from the module case and chassis ground within the module.
 2. Shall be pulled up with 4.7k-10kohms to a voltage between 3.15 V and 3.45 V on the host board.

Datasheet

Mechanical Drawing

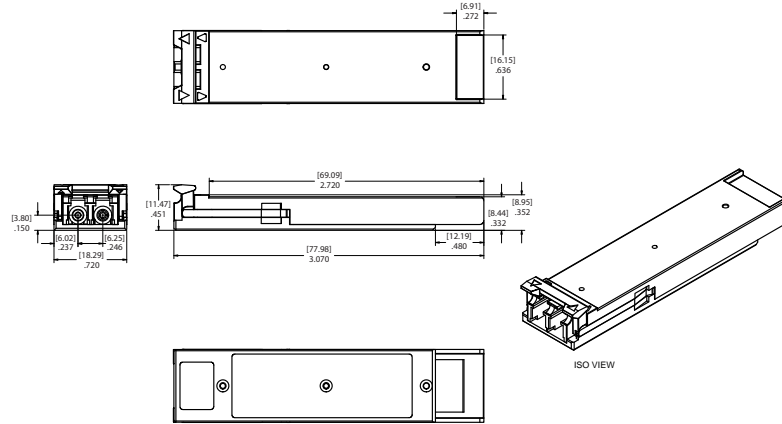

1. MRV'S XFP TRANSCEVERS ARE COMPLIANT WITH THE DIMENSIONS DEFINED BY XFP MULTISOURCING AGREEMENT (MSA).
NOTES: UNLESS OTHERWISE SPECIFIED

Ordering Information

Model	Description	Data Rate (Gbps)	Wavelength (nm)	Dispersion Tolerance (ps/nm)	Bail Latch Color	Distance Range* (km)
XFP-10GD-LR12P	10 GbE, 10G FC, or OC-192/STM-64 single-mode XFP transceiver with Digital Diagnostics. Requires external reference clock.	9.953 - 11.318	1550	2400	White	36 - 120

* Dispersion tolerance is specified for 120 km reach. Use EDFA to span beyond 80 km.

Regulatory and Industry Compliances

Class 1 Laser Product, complies with EN 60825-1 and 21 CFR 1040.10 except for deviations pursuant to Laser Notice No. 50. dated June 24, 2007
MSA INF-8077i; Telcordia GR-468, GR-253; Digital Diagnostic SFF-8472; ITU-T G-825; IEEE 802.3ae
Certified by one or more of the following agencies: TÜV, UL, CSA
RoHS Directive; China RoHS; California RoHS Law, REACH Directive SVHC; WEEE Directive
The Quality Management System is certified to ISO 9001 by QMI-SAI Global
The Environmental Management System is in compliance with ISO 14001

Warnings

Handling Precautions: This device is susceptible to damage as a result of electrostatic discharge (ESD). A static free environment is highly recommended. Follow guidelines according to proper ESD procedures.

Laser Safety: Radiation emitted by laser devices can be dangerous to human eyes. Avoid eye exposure to direct or indirect radiation.

MRV has more than 50 offices throughout the world. Addresses, phone numbers and fax numbers are listed at www.mrv.com. Please e-mail us at info@mrv.com or call us for assistance.

MRV Los Angeles
20415 Nordhoff Street
Chatsworth, CA 91311
800-338-5316
818-773-0900

MRV Boston
300 Apollo Drive
Chelmsford, MA 01824
800-338-5316
978-674-6800

MRV International
Business Park Moerfelden
Waldeckerstrasse 13
64546 Moerfelden-Walldorf
Germany
Tel. (49) 6105/2070
Fax (49) 6105/207-100

All statements, technical information and recommendations related to the products herein are based upon information believed to be reliable or accurate. However, the accuracy or completeness thereof is not guaranteed, and no responsibility is assumed for any inaccuracies. Please contact MRV Communications for more information. MRV Communications and the MRV Communications logo are trademarks of MRV Communications, Inc. Other trademarks are the property of their respective holders.