

Datasheet

Multi-Rate (10 Gbps) Single-Mode XFP Transceivers

XFP-10GD-LR



Highlights

- XFP transceiver
- Data Rates: 9.953 - 11.318 Gbps
- Protocols:
 - SDH STM-64
 - SONET OC-192
 - SONET OC-192 with FEC
 - 10 Gbps Ethernet (LAN, WAN)
 - 10 Gbps Ethernet (LAN, WAN) with FEC
 - 10 Gbps Fibre Channel
 - 10 Gbps Fibre Channel with FEC
- Single-mode dual-fiber (Tx/Rx)
- 1310 nm
- 0 to 10 km
- Duplex LC connector
- Digital Diagnostics (SFF-8472)
- XFI Loopback
- Hot-swap

Overview

MRV Communications' XFP transceivers provide the high speeds and compact dimensions that today's demanding networks require while delivering the deployment flexibility and inventory control that network administrators demand. Designed to Multi-Source Agreement (MSA) standards for broadest compatibility, they perfectly match MRV's wide range of optical transport solutions.

Visit the MRV website at www.mrv.com or contact your nearest authorized MRV Communications dealer for more information.

Specifications Overview	
Data Rate	9.953 - 11.318 Gbps
Tx Wavelength	1310 nm
Tx Power (Minimum)	-6 dBm
Tx Disable	Yes
Rx Wavelength Range	1270 - 1600 nm
Rx Sensitivity @ 10.5 Gbps	-14.4 dBm
Rx Sensitivity @ 11.3 Gbps	-13.4 dBm
Rx Saturation	0.5 dBm
Extinction Ratio	6 dB
Operating Temperature Range	-5 to 75°C
Power Consumption	< 2 Watt

Datasheet

Optical Specifications					
Parameter	Symbol	Minimum	Maximum	Unit	Notes
Transmitter					
Output Optical Power @ 9/125 SMF	P_{OUT}	-6	-1	dBm	1
Optical Wavelength	λ	1290	1330	nm	-
Optical Extinction Ratio	ER	6	-	dB	1
Sidemode Suppression Ratio	SSR_{min}	30	-	dB	-
Tx Jitter Generation (peak-to-peak)	Tx_j	-	0.1	UI	-
Tx Jitter Generation (RMS)	Tx_{jRMS}	-	0.01	UI	-
Relative Intensity Noise	RIN	-	-130	dB/Hz	-
Receiver					
Receiver Sensitivity @ 10.5Gbps	R_{SENS1}	-	-14.4	dBm	2
Receiver Sensitivity @ 11.3Gbps	R_{SENS2}	-	-13.4	dBm	2
Maximum Input Power	P_{MAX}	0.5	-	dBm	-
Optical Center Wavelength	λ_C	1270	1600	nm	-
LOS Assert	LOS_A	-32	-	dBm	-
LOS De-Assert	LOS_D	-	-18	dBm	-
LOS Hysteresis	-	0.5	-	dB	-
Receiver Reflectance	R_{rx}	-	-14	dB	-

- Notes:**
1. Having ER = 6 dB guarantees that the -6 dBm minimum output power meets IEEE 802.3ae requirement of OMA=-5.2dBm.
 2. Measured with worst ER; BER<10⁻¹²; 2³¹-1 PRBS. Complies with -12.6 dBm OMA at ER = 6 dB.

Absolute Maximum Rating					
Parameter	Symbol	Min.	Max.	Unit	Notes
Supply Voltage (3.3V)	V_{CC3}	-0.5	4.0	V	-
Storage Temperature	T_S	-40	85	°C	-
Case Operating Temperature	T_{OP}	-5	75	°C	-

General Specifications					
Parameter	Symbol	Min	Max	Unit	Notes
Bit Rate	BR	9.953	11.318	Gbps	1
Bit Error Ratio	BER	-	10 ⁻¹²	-	2
Transmission Distance*	L_{MAX}	0	10	km	1

- Notes:**
1. SONET OC-192 SR-1, SDH STM I-64.1, 10GBASE-LR/LW, SONET OC-192 with FEC, 10GBASE-LR/LW + FEC
 2. Tested with a 2³¹ - 1 PRBS

Datasheet

Electrical Specifications

Parameter	Symbol	Minimum	Maximum	Unit	Notes
Supply Voltage	V_{CC3}	3.13	3.45	V	-
Supply Current	I_{CC3}	-	600	mA	-
Module Total Power	P	-	2.0	W	1
Transmitter					
Input Differential Impedance	R_{in}	80	120	Ω	2
Differential Data Input Swing	V_{in} , pp	120	820	mV	3
Transmit Disable Voltage	V_D	2.0	V_{CC}	V	4
Transmit Enable Voltage	V_{EN}	GND	GND+0.8	V	-
Transmit Disable Assert Time	-	-	10	us	-
Receiver					
Differential Data Output Swing	V_{out} , pp	340	850	mV	5
Data Output Rise Time	t_r	-	38	ps	6
Data Output Fall Time	t_f	-	38	ps	6
LOS Fault	$V_{LOS\ fault}$	GND	$V_{CC\ HOST}$	V	7
LOS Normal	$V_{LOS\ norm}$	-	GND+0.5	V	7
Power Supply Rejection	PSR	See Note 8 Below			8

- Notes:**
- Maximum total power value is specified across the full temperature and voltage range.
 - After internal AC coupling.
 - SONET/SDH jitter generation requirements are guaranteed with a minimum differential data input swing of 500 mV peak-to-peak.
 - Or open circuit.
 - Into 100 ohms differential termination.
 - 20 – 80 %
 - Loss Of Signal is open collector to be pulled up with a 4.7 k – 10 kohm resistor to 3.15 – 3.6 V. Logic 0 indicates normal operation; logic 1 indicates no signal detected.
 - Per Section 2.7.1. in the XFP MSA Specification (Rev 4.5 – August 2005).

Host Board Connector Pinout

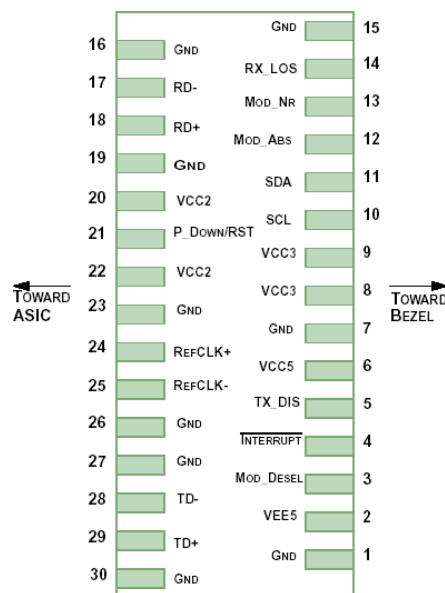

Datasheet

Host Board Connector Legend				
Pin	Logic	Symbol	Name/Description	Note
1	-	GND	Module Ground	1
2	-	V _{EES}	Optional -5.2 V Power Supply (Not Required)	-
3	LVTTTL-I	Mod_DeSel	Module De-Select; When Held Low Allows Module to Respond to 2-Wire Serial Interface	-
4	LVTTTL-O	$\overline{\text{Interrupt}}$	$\overline{\text{Interrupt}}$; Indicates Presence of an Important Condition Which Can Be Read Over the 2-Wire Serial Interface	2
5	LVTTTL-I	TX_DIS	Transmitter Disable; Transmitter Laser Source Turned Off	-
6	-	V _{CC5}	+5 V Power Supply (Not Required)	-
7	-	GND	Module Ground	1
8	-	V _{CC3}	+3.3 V Power Supply	-
9	-	V _{CC3}	+3.3 V Power Supply	-
10	LVTTTL-I/O	SCL	2-Wire Serial Interface Clock	2
11	LVTTTL-I/O	SDA	2-Wire Serial Interface Data Line	2
12	LVTTTL-O	Mod_Abs	Indicates Module is Not Present. Grounded in the Module	2
13	LVTTTL-O	Mod_NR	Module Not Ready; Indicating Module Operational Fault	2
14	LVTTTL-O	RX_LOS	Receiver Loss of Signal Indicator	2
15	-	GND	Module Ground	1
16	-	GND	Module Ground	1
17	CML-O	RD-	Receiver Inverted Data Output	-
18	CML-O	RD+	Receiver Non-Inverted Data Output	-
19	-	GND	Module Ground	1
20	-	V _{CC2}	+1.8 V Power Supply (Not Required)	-
21	LVTTTL-I	P_Down/RST	Power Down; When High, Places the Module in the Low Power Stand-By Mode and on the Falling Edge of P_Down Initiates a Module Reset	-
			Reset; The Falling Edge Initiates a Complete Reset of the Module Including the 2-Wire Serial Interface, Equivalent to a Power Cycle.	
22	-	V _{CC2}	+1.8 V Power Supply (Not Required)	-
23	-	GND	Module Ground	1
24	PECL-I	RefCLK+	Reference Clock Non-Inverted Input, AC Coupled on the Host Board (Not Required)	3
25	PECL-I	RefCLK-	Reference Clock Inverted Input, AC Coupled on the Host Board (Not Required)	3
26	-	GND	Module Ground	1
27	-	GND	Module Ground	1
28	CML-I	TD-	Transmitter Inverted Data Input	-
29	CML-I	TD+	Transmitter Non-Inverted Data Input	-
30	-	GND	Module Ground	1

- Notes:**
1. Module circuit ground is isolated from module chassis ground within the module.
 2. Open collector; should be pulled up with 4.7 k – 10 kohms on host board to a voltage between 3.15 V and 3.6 V.
 3. A Reference Clock input is not required by the XFP-10GD-LR. If present, it will be ignored.

Datasheet

Mechanical Drawing

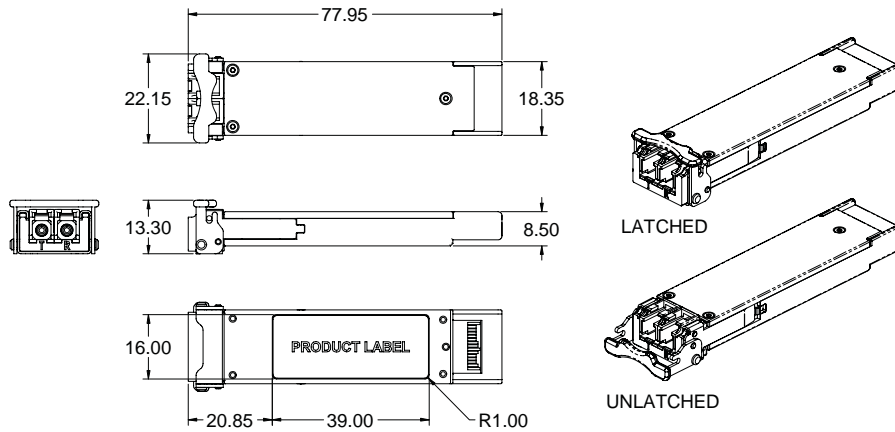

XFP Transceiver (dimensions are in mm)

Ordering Information

Model	Description	Data Rate (Gbps)	Wavelength (nm)	Bail Latch Color	Distance (km)
XFP-10GD-LR	OC192/STM-64, 10GE or 10G FC, single-mode XFP transceiver with Digital Diagnostics.	9.953 - 11.318	1310	Blue	10

Regulatory and Industry Compliances

Class 1 Laser Product, complies with EN 60825-1 and 21 CFR 1040.10 except for deviations pursuant to Laser Notice No. 50. dated June 24, 2007
MSA INF-8077i; Digital Diagnostic SFF-8472

Certified by one or more of the following agencies: TÜV, UL, CSA

RoHS Directive; China RoHS; California RoHS Law, REACH Directive SVHC; WEEE Directive

The Quality Management System is certified to ISO 9001 by QMI-SAI Global

The Environmental Management System is in compliance with ISO 14001

Warnings

Handling Precautions: This device is susceptible to damage as a result of electrostatic discharge (ESD). A static free environment is highly recommended. Follow guidelines according to proper ESD procedures.

Laser Safety: Radiation emitted by laser devices can be dangerous to human eyes. Avoid eye exposure to direct or indirect radiation.

MRV has more than 50 offices throughout the world. Addresses, phone numbers and fax numbers are listed at www.mrv.com. Please e-mail us at info@mrv.com or call us for assistance.

MRV Los Angeles
20415 Nordhoff Street
Chatsworth, CA 91311
800-338-5316
818-773-0900

MRV Boston
300 Apollo Drive
Chelmsford, MA 01824
800-338-5316
978-674-6800

MRV International
Business Park Moerfelden
Waldeckerstrasse 13
64546 Moerfelden-Walldorf
Germany
Tel. (49) 6105/2070
Fax (49) 6105/207-100

All statements, technical information and recommendations related to the products herein are based upon information believed to be reliable or accurate. However, the accuracy or completeness thereof is not guaranteed, and no responsibility is assumed for any inaccuracies. Please contact MRV Communications for more information. MRV Communications and the MRV Communications logo are trademarks of MRV Communications, Inc. Other trademarks are the property of their respective holders.