

Datasheet

10 Gbps Dual Rate 850 nm Multi-Mode XFP Transceivers

XFP-10GD-SX



Highlights

- XFP transceiver
- Data Rates: 9.95 - 10.5 Gbps
- Protocols:
 - 10 Gbps Ethernet
 - 10 Gbps Fibre Channel
- Multi-mode fiber
- Dual Fiber (Tx/Rx)
- 850 nm
- 0 to 300 meters
- Duplex LC connector
- Digital Diagnostics (SFF-8472)
- XFI Loopback
- Hot-swap

Overview

MRV Communications' XFP transceivers provide the high speeds and compact dimensions that today's demanding networks require while delivering the deployment flexibility and inventory control that network administrators demand. Designed to Multi-Source Agreement (MSA) standards for broadest compatibility, they perfectly match MRV's wide range of optical transport solutions.

Visit the MRV website at www.mrv.com or contact your nearest authorized MRV Communications dealer for more information.

Specifications Overview

Data Rate	9.95 - 10.5 Gbps
Tx Wavelength	850 nm
Tx Power (Minimum)	-5.0 dBm
Tx Dispersion Penalty	3.9 dB
Tx Disable	Yes
Rx Wavelength Range	840 - 860 nm
Rx Sensitivity in OMA @ 10.5 Gbps	-11.1 dBm
Rx Saturation	0.5 dBm
Optical Extinction Ratio	3.0 dB
Operating Temperature Range	0 to 70°C
Power Consumption	< 1.5 Watts

Datasheet

Optical Specifications

Parameter	Symbol	Minimum	Maximum	Unit	Notes
Transmitter					
Optical Modulation Amplitude (OMA)	P_{OMA}	-2.8	-	dBm	-
Average Optical Power	P_{AVE}	-5	-1	dBm	1
Optical Wavelength	λ	840	860	nm	-
RMS Spectral Width	$\Delta\lambda_{rms}$	-	0.45	nm	-
Optical Extinction Ratio	ER	3.0	-	dB	-
Transmitter and Dispersion Penalty	TDP	-	3.9	dB	-
Average Launch power of OFF transmitter	P_{OFF}	-	-30	dBm	-
Tx Jitter	T_{xj}	Per 802.3ae Requirements			-
Encircled Flux	$< 4.5 \mu m$	-	30	%	2
Encircled Flux	$< 19 \mu m$	86	-	%	2
Relative Intensity Noise	RIN_{12OMA}	-	-128	dB/Hz	-
Receiver					
Receiver Sensitivity (OMA) @ 10.5 Gbps	R_{SENS1}	-	-11.1	dBm	3
Stressed Receiver Sensitivity (OMA) @ 10.3 Gbps	R_{SENS2}	-	-7.5	dBm	4
Maximum Input Power	P_{MAX}	0.5	-	dBm	-
Wavelength Range	λ_C	840	860	nm	-
Receiver Reflectance	R_{rx}	-	-12	dB	-
LOS Assert	LOS_A	-	-12	dBm	-
LOS De-Assert	LOS_D	30	-	dBm	-
LOS Hysteresis	-	0.5	-	dB	-

- Notes:**
1. Average power figures are informative only, per IEEE 802.3ae.
 2. Measured into Type A1a (50/125 μm multi-mode) fiber per ANSI/TIA/EIA-455-203-2.
 3. Measured with worst ER; BER < 10^{-12} ; $2^{31} - 1$ PRBS.
 4. Per IEEE 802.3ae.

Absolute Maximum Rating

Parameter	Symbol	Min.	Max.	Unit	Notes
Maximum Supply Voltage (3.3V)	V_{CC3}	-0.5	4.0	V	-
Storage Temperature	T_S	-40	85	°C	-
Case Operating Temperature	T_{OP}	0	70	°C	-

General Specifications

Parameter	Symbol	Min	Max	Unit	Notes
Bit Rate	BR	9.95	10.5	Gbps	1
Bit Error Ratio	BER	-	10^{-12}	-	2

- Notes:**
1. 10GBASE-SR/SW, 1200-Mx-SN-I
 2. Tested with a $2^{31} - 1$ PRBS

Maximum Supported Distances

Fiber Type	850 OFL Bandwidth	Symbol	Min	Max	Unit	Notes
62.5 μm	160 MHz/km	L_{MAX}	-	26	m	-
62.5 μm	OM1: 200 MHz/km	L_{MAX}	-	33	m	-
50 μm	400 MHz/km	L_{MAX}	-	66	m	-
50 μm	OM2: 500 MHz/km	L_{MAX}	-	82	m	-
50 μm	OM3: 2000 MHz/km	L_{MAX}	-	300	m	-

Datasheet

Electrical Specifications

Parameter	Symbol	Minimum	Maximum	Unit	Notes
Supply Voltage	Vcc3	3.13	3.45	V	-
Supply Current	Icc3	-	400	mA	-
Module Total Power	P	-	1.5	W	1
Transmitter					
Input Differential Impedance	R _{in}	80	120	Ω	2
Differential Data Input Swing	V _{in} , pp	120	1000	mV	-
Transmit Disable Voltage	V _D	2.0	Vcc	V	3
Transmit Enable Voltage	V _{EN}	GND	GND + 0.8	V	-
Transmit Disable Assert Time	-	-	10	us	-
Receiver					
Differential Data Output Swing	V _{out} , pp	600	800	mV	4
Data Output Rise Time	t _r	-	40	ps	5
Data Output Fall Time	t _f	-	40	ps	5
LOS Fault	V _{LOS fault}	Vcc - 0.5	Vcc _{HOST}	V	6
LOS Normal	V _{LOS norm}	GND	GND + 0.5	V	6
Power Supply Rejection	PSR	See Note 6 Below			7

- Notes:**
- Maximum total power value is specified across the full temperature and voltage range.
 - After internal AC coupling.
 - Or open circuit.
 - Into 100 ohms differential termination.
 - 20 – 80 %
 - Loss Of Signal is open collector to be pulled up with a 4.7 k – 10 kohm resistor to 3.15 – 3.6 V. Logic 0 indicates normal operation; logic 1 indicates no signal detected.
Per Section 2.7.1. in the XFP MSA Specification.
 -

Host Board Connector Pinout

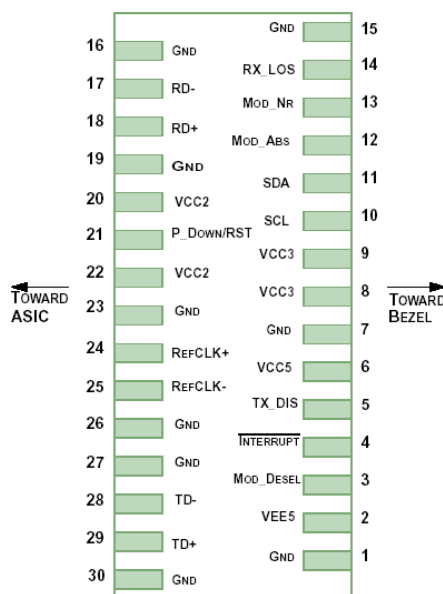

Datasheet

Host Board Connector Legend				
Pin	Logic	Symbol	Name/Description	Note
1	-	GND	Module Ground	1
2	-	VEES	Optional -5.2 V Power Supply (Not Required)	-
3	LVTTTL-I	Mod_DeSel	Module De-Select; When Held Low Allows Module to Respond to 2-Wire Serial Interface	-
4	LVTTTL-O	<u>Interrupt</u>	Interrupt (bar); Indicates Presence of an Important Condition Which Can Be Read Over the 2-Wire Serial Interface	2
5	LVTTTL-I	TX_DIS	Transmitter Disable; Transmitter Laser Source Turned Off	-
6	-	VCC5	+5 V Power Supply (Not Required)	-
7	-	GND	Module Ground	1
8	-	VCC3	+3.3 V Power Supply	-
9	-	VCC3	+3.3 V Power Supply	-
10	LVTTTL-I	SCL	2-Wire Serial Interface Clock	2
11	LVTTTL-I/O	SDA	2-Wire Serial Interface Data Line	2
12	LVTTTL-O	Mod_Abs	Indicates Module is Not Present. Grounded in the Module	2
13	LVTTTL-O	Mod_NR	Module Not Ready; MRV defines it as a logical OR between RX_LOS and Loss of Lock in TX/RX.	2
14	LVTTTL-O	RX_LOS	Receiver Loss of Signal Indicator	2
15	-	GND	Module Ground	1
16	-	GND	Module Ground	1
17	CML-O	RD-	Receiver Inverted Data Output	-
18	CML-O	RD+	Receiver Non-Inverted Data Output	-
19	-	GND	Module Ground	1
20	-	VCC2	+1.8 V Power Supply (Not Required)	-
21	LVTTTL-I	P_Down/RST	Power Down; When High, Places the Module in the Low Power Stand-By Mode and on the Falling Edge of P_Down Initiates a Module Reset	-
			Reset; The Falling Edge Initiates a Complete Reset of the Module Including the 2-Wire Serial Interface, Equivalent to a Power Cycle.	
22	-	VCC2	+1.8 V Power Supply (Not Required)	-
23	-	GND	Module Ground	1
24	PECL-I	RefCLK+	Reference Clock Non-Inverted Input, AC Coupled on the Host Board (Not Required)	3
25	PECL-I	RefCLK-	Reference Clock Inverted Input, AC Coupled on the Host Board (Not Required)	3
26	-	GND	Module Ground	1
27	-	GND	Module Ground	1
28	CML-I	TD-	Transmitter Inverted Data Input	-
29	CML-I	TD+	Transmitter Non-Inverted Data Input	-
30	-	GND	Module Ground	1

- Notes:**
1. Module circuit ground is isolated from module chassis ground within the module.
 2. Open collector; should be pulled up with 4.7 k – 10 kohms on host board to a voltage between 3.15 V and 3.6 V.
 3. A Reference Clock input is not required by the XFP-10GD-SX. If present, it will be ignored.

Datasheet

Mechanical Drawing

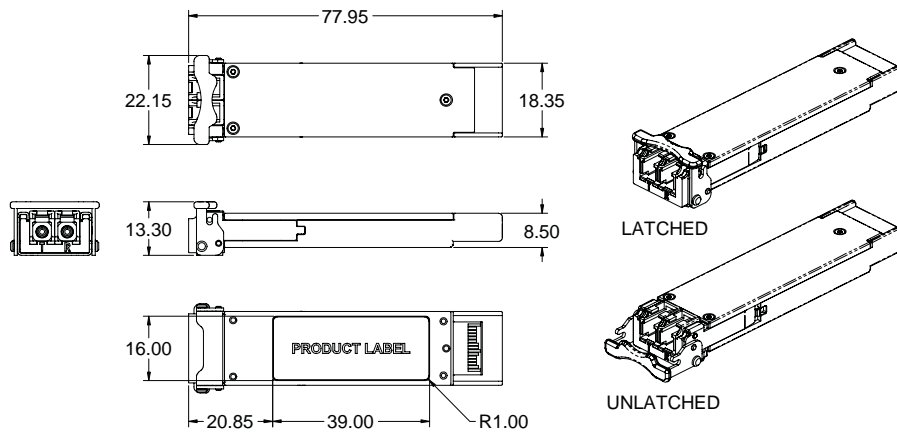

XFP Transceiver (dimensions are in mm)

Ordering Information

Model	Description	Data Rate (Gbps)	Wavelength (nm)	Bail Latch Color	Distance Range (m)
XFP-10GD-SX	10GE or 10G FC, multi-mode XFP transceiver with Digital Diagnostics.	9.95 - 10.5	850	Beige	0 - 300

Regulatory and Industry Compliances

Class 1 Laser Product, complies with EN 60825-1 and 21 CFR 1040.10 except for deviations pursuant to Laser Notice No. 50. dated June 24, 2007
 MSA INF-8077i; Telcordia GR-468; Digital Diagnostic SFF-8472; IEEE 802.3ae
 Certified by one or more of the following agencies: TÜV, UL, CSA
 RoHS Directive; China RoHS; California RoHS Law, REACH Directive SVHC; WEEE Directive
 The Quality Management System is certified to ISO 9001 by QMI-SAI Global
 The Environmental Management System is in compliance with ISO 14001

Warnings

Handling Precautions: This device is susceptible to damage as a result of electrostatic discharge (ESD). A static free environment is highly recommended. Follow guidelines according to proper ESD procedures.

Laser Safety: Radiation emitted by laser devices can be dangerous to human eyes. Avoid eye exposure to direct or indirect radiation.

MRV has more than 50 offices throughout the world. Addresses, phone numbers and fax numbers are listed at www.mrv.com. Please e-mail us at info@mrv.com or call us for assistance.

MRV Los Angeles
 20415 Nordhoff Street
 Chatsworth, CA 91311
 800-338-5316
 818-773-0900

MRV Boston
 300 Apollo Drive
 Chelmsford, MA 01824
 800-338-5316
 978-674-6800

MRV International
 Business Park Moerfelden
 Waldeckerstrasse 13
 64546 Moerfelden-Walldorf
 Germany
 Tel. (49) 6105/2070
 Fax (49) 6105/207-100

All statements, technical information and recommendations related to the products herein are based upon information believed to be reliable or accurate. However, the accuracy or completeness thereof is not guaranteed, and no responsibility is assumed for any inaccuracies. Please contact MRV Communications for more information. MRV Communications and the MRV Communications logo are trademarks of MRV Communications, Inc. Other trademarks are the property of their respective holders.