

Datasheet

10 Gbps Ethernet 1550nm XFP Transceivers

XFP-10GED-IR2



Highlights

- XFP enclosure
- Data Rate: 10.3125 Gbps
- Protocol:
 - 10 Gigabit Ethernet
- Single-mode dual-fiber (Tx/Rx)
- 1550 nm (Tx)
- 0 to 40 km range
- Duplex LC connector
- Digital Diagnostics (SFF-8472)
- XFI Loopback
- Hot-swap

Overview

MRV Communications’ XFP transceivers provide the high speeds and compact dimensions that today’s demanding networks require while delivering the deployment flexibility and inventory control that network administrators demand. Designed to Multi-Source Agreement (MSA) standards for broadest compatibility, they perfectly match MRV’s wide range of optical transport solutions.

Visit the MRV website at www.mrv.com or contact your nearest authorized MRV Communications dealer for more information.

Specifications Overview	
Data Rate	10.3125 Gbps
Tx Wavelength	1550 nm
Tx Power in OMA (Minimum)	-1.7 dBm
Tx Disable	Yes
Rx Wavelength	1260 - 1600 nm
Rx Sensitivity in OMA (Maximum)	-14.1 dBm
Rx Overload	-1 dBm
Extinction Ratio	3.0 dB
Optical Eye Mask	Compliant with IEEE 802.3-2005
Operating Temperature Range	-5 to 70 °C
Power Consumption	3.5 Watt

Datasheet

Absolute Maximum Rating

Parameter	Symbol	Min.	Max.	Unit	Notes
Supply Voltage (3.3V)	V _{CC3}	-0.5	4.0	V	-
Supply Voltage (5.0V)	V _{CC5}	-0.5	6.0	V	-
Operating Relative Humidity	RH	-	85	%	-
Storage Temperature	T _s	-40	85	°C	-

Recommended Operation Conditions

Parameter	Symbol	Min	Max	Unit	Notes
Operating Temperature (Case)	T _C	-5	70	°C	-
Power Supply Voltage (3.3V)	V _{CC3}	3.14	3.46	V	-
Power Supply Voltage (5V)	V _{CC5}	4.75	5.25	V	-
Power Supply Current (3.3V)	I _{CC3}	-	750	mA	-
Power Supply Current (5V)	I _{CC5}	-	200	mA	-
Power Dissipation	P _D	-	3.5	W	-
Bit Rate	BR	9.953	11.1	Gbps	-
Transmission Distance	TD	2	40,000	m	1

Notes: 1. Measured with G.652 SMF

Optical Specifications

Parameter	Symbol	Minimum	Maximum	Unit	Notes
Operating Data Rate	DR	-	10.3125	Gbps	-
Transmitter					
Center Wavelength	λ _C	1530	1565	nm	-
Average Output Power	P _{OUT}	-4.7	4.0	dBm	1
Optical Modulation Amplitude	OMA	-1.7	-	dBm	1
Average Output Power (Laser Off)	P _{OUT-OFF}	-	-30	dBm	1
Side Mode Suppression Ration	SMSR	30	-	dB	-
Extinction Ratio	ER	3.0	-	dB	2
Transmitter and Dispersion Penalty	TDP	-	3.0	dB	2
Optical Return Loss Tolerance	ORLT	-	12	dB	-
Optical Eye Mask	Compliant with IEEE 802.3-2005				-
Receiver					
Center Wavelength	λ _C	1530	1565	nm	-
Receiver Sensitivity	P _{IN-SENS}	-	-15.8	dBm	3
Receiver Sensitivity in OMA	P _{IN-SENS(OMa)}	-	-14.1	dBm	3
Receiver Overload	P _{IN-OL}	-1.0	-	dBm	3
Receiver Reflectance	Ref	-	-26	dB	-
LOS Assert	LOS _A	-25	-	dBm	-
LOS De-Assert	LOS _D	-	-16	dBm	-
LOS Hysteresis	-	0.5	4	dB	-

Notes: 1. The optical power is launched into SMF.
 2. Measured with a PRBS 2³¹-1 test pattern @10.3125 Gbps.
 3. Measured with a PRBS 2³¹-1 test pattern @10.3125 Gbps, BER ≤ 10⁻¹².

Datasheet

Electrical Specifications

Parameter	Symbol	Minimum	Maximum	Unit	Notes
Transmitter					
Differential Data Input Amplitude	$V_{IN,P-P}$	120	1000	mVpp	-
Input Differential Impedance	Z_{IN}	85	115	Ω	-
Tx_Disable, P_Down/RST (Low)	V_{IL}	-0.3	0.8	V	-
Tx_Disable, P_Down/RST (High)	V_{IH}	2.0	$V_{CC} + 0.3$	V	-
Receiver					
Differential Data Output Amplitude	$V_{OUT,P-P}$	600	800	mVpp	-
Output Differential Impedance	Z_D	80	120	Ω	-
Output Rise Time, 20%~80%	T_R	24	-	ps	-
Output Fall Time, 20%~80%	T_F	24	-	ps	-
Rx_LOS, Mod_NR, Interrupt (Low)	V_{OL}	0	0.4	V	-
Rx_LOS, Mod_NR, Interrupt (High)	V_{OH}	$V_{CC} - 0.5$	$V_{CC} + 0.3$	V	-

Host Board Connector Pinout

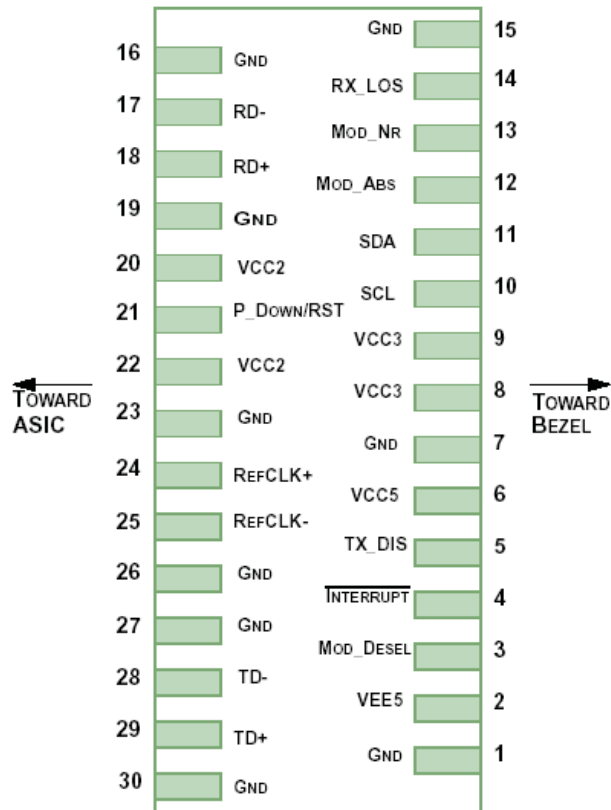

Datasheet

Host Board Connector Legend				
Pin	Logic	Symbol	Name/Description	Notes
1		GND	Module Ground	1
2		V _{EE5}	Optional -5.2 V power supply (Not Implemented)	
3	LVTTTL-I	Mod_DeSel	Module De-Select; When held low allows module to respond to 2-wire serial interface	
4	LVTTTL-O	Interrupt	Interrupt; Indicates presence of an important condition which can be read over the 2-wire serial interface	2
5	LVTTTL-I	TX_DIS	Transmitter Disable; Turns off transmitter laser output	
6		V _{CC5}	+5 V Power Supply	
7		GND	Module Ground	1
8		V _{CC3}	+3.3 V Power Supply	
9		V _{CC3}	+3.3 V Power Supply	
10	LVTTTL-I/O	SCL	2-Wire Serial Interface Clock	2
11	LVTTTL-I/O	SDA	2-Wire Serial Interface Data Line	2
12	LVTTTL-O	Mod_Abs	Indicates module is not present. Grounded in the module	2
13	LVTTTL-O	Mod_NR	Module Not Ready; Indicating module operational fault	2
14	LVTTTL-O	RX_LOS	Receiver Loss of Signal Indicator	2
15		GND	Module Ground	1
16		GND	Module Ground	1
17	CML-O	RD-	Receiver Inverted Data Output	
18	CML-O	RD+	Receiver Non-Inverted Data Output	
19		GND	Module Ground	1
20		V _{CC2}	+1.8 V Power Supply (Not Implemented)	3
21	LVTTTL-I	P_Down/RST	Power Down; When high, requires the module to limit power consumption to 1.5 W or below. 2-wire serial interface must be functional in the low power mode.	
			Reset; The falling edge initiates a complete reset of the module including the 2-wire serial interface, equivalent to a power cycle.	
22		V _{CC2}	+1.8 V Power Supply (Not Implemented)	3
23		GND	Module Ground	1
24	PECL-I	RefCLK+	Not used, internally terminated to 50 ohm (100 ohm diff).	4
25	PECL-I	RefCLK-	Not used, internally terminated to 50 ohm (100 ohm diff).	4
26		GND	Module Ground	1
27		GND	Module Ground	1
28	CML-I	TD-	Transmitter Inverted Data Input	
29	CML-I	TD+	Transmitter Non-Inverted Data Input	
30		GND	Module Ground	1

- Note:**
1. Module ground pins GND are isolated from the module case and chassis ground within the module.
 2. Shall be pulled up with 4.7 K-10 Kohms to a voltage between 3.15 V and 3.45 V on the host board.
 3. The pins are open within module.
 4. Reference Clock is not required.

Datasheet

Monitoring Specifications

Data Address	Parameter	Range	Accuracy	Notes
96-97	Temperature	-10 to 80 °C	± 3 °C	-
100-101	Bias Current	0 to 100 mA	± 10 %	-
102-103	TX Power	-6 to 5 dBm	± 2 dB	-
104-105	RX Power	-15 to 0 dBm	± 2 dB	-
106-107	V _{CC5} Voltage	+4.5 V to +5.5 V	± 3 %	-
108-109	V _{CC3} Voltage	+3.0 V to +3.7 V	± 3 %	-

Mechanical Drawing

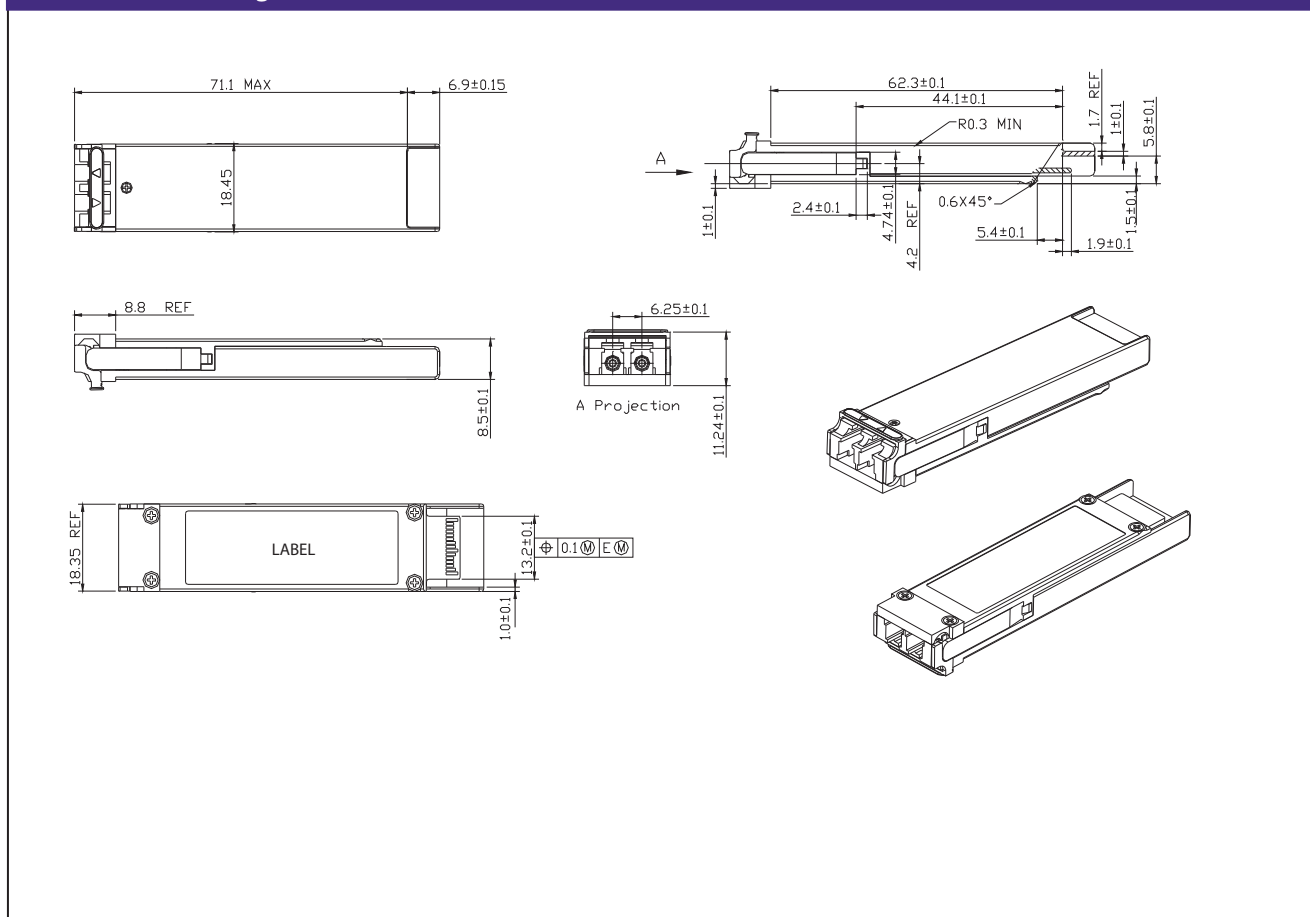

Datasheet

Ordering Information

Model	Description	Data Rate (Gbps)	Wavelength (nm)	Dispersion Penalty (dB)	Bail Latch Color	Distance Range (km)
XFP-10GED-IR2	10 GbE single-mode XFP transceiver with Digital Diagnostics.	10.3125	1550	3.0	Magenta	0 - 40

Regulatory and Industry Compliances

Class 1 Laser Product, complies with EN 60825-1 and 21 CFR 1040.10 except for deviations pursuant to Laser Notice No. 50, dated June 24, 2007
MSA INF-8077i; Digital Diagnostic SFF-8472

Certified by one or more of the following agencies: TÜV, UL, CSA

RoHS Directive; China RoHS; California RoHS Law, REACH Directive SVHC; WEEE Directive

The Quality Management System is certified to ISO 9001 by QMI-SAI Global

The Environmental Management System is in compliance with ISO 14001

Warnings

Handling Precautions: This device is susceptible to damage as a result of electrostatic discharge (ESD). A static free environment is highly recommended. Follow guidelines according to proper ESD procedures.

Laser Safety: Radiation emitted by laser devices can be dangerous to human eyes. Avoid eye exposure to direct or indirect radiation.

MRV has more than 50 offices throughout the world. Addresses, phone numbers and fax numbers are listed at www.mrv.com.
Please e-mail us at info@mrv.com or call us for assistance.

MRV Los Angeles
20415 Nordhoff Street
Chatsworth, CA 91311
800-338-5316
818-773-0900

MRV Boston
300 Apollo Drive
Chelmsford, MA 01824
800-338-5316
978-674-6800

MRV International
Business Park Moerfelden
Waldeckerstrasse 13
64546 Moerfelden-Walldorf
Germany
Tel. (49) 6105/2070
Fax (49) 6105/207-100

All statements, technical information, and recommendations related to the products herein are based upon information believed to be reliable or accurate. However, the accuracy or completeness thereof is not guaranteed, and no responsibility is assumed for any inaccuracies. Please contact MRV Communications for more information. MRV Communications and the MRV Communications logo are trademarks of MRV Communications, Inc. Other trademarks are the property of their respective holders.