

Datasheet

10 Gbps Dual Rate 850 nm Multi-Mode XFP Transceivers

XFP-10GED-SX



Highlights

- XFP enclosure
- Data Rates: 9.953 - 10.3125 Gbps
- 10G Ethernet Protocols:
 - 10GBASE-SR (LAN)
 - 10GBASE-SW (WAN)
- Multi-mode fiber
- Dual fiber (Tx/Rx)
- 850 nm (Tx)
- 2 to 300 m range
- Duplex LC connector
- Digital Diagnostics (SFF-8472)
- XFI Loopback
- Hot-swap

Overview

MRV Communications’ XFP transceivers provide the high speeds and compact dimensions that today’s demanding networks require while delivering the deployment flexibility and inventory control that network administrators demand. Designed to Multi-Source Agreement (MSA) standards for broadest compatibility, they perfectly match MRV’s wide range of optical transport solutions.

Visit the MRV website at www.mrv.com or contact your nearest authorized MRV Communications dealer for more information.

Specifications Overview	
Data Rate	9.953 - 10.3125 Gbps
Tx Wavelength	850 nm
Tx Power in OMA (Minimum)	-7.3 dBm
Tx Disable	Yes
Rx Wavelength	840 - 860 nm
Rx Sensitivity in OMA (Maximum)	-11.1 dBm
Rx Saturation	-1 dBm
Extinction Ratio	3.0 dB
Operating Temperature Range	-5 to 70 °C
Power Consumption	1.5 Watt

Datasheet

Optical Specifications

Parameter	Symbol	Minimum	Maximum	Unit	Notes
Operating Data Rate	DR	9.953	10.3125	Gbps	-
Center Wavelength	λ_C	840	860	nm	-
Transmitter					
Average Output Power	P_{OUT}	-7.3	-1.0	dBm	1
Extinction Ratio	ER	3.0	-	dB	2
Optical Modulation Amplitude	OMA	-	-	dBm	3
Spectral Width	$\Delta\lambda$	-	-	nm	3
Dispersion Penalty	DP	-	3.9	dB	-
Optical Eye Mask	Compatible with IEEE P802.3ae				-
Receiver					
Receiver Sensitivity	P_{IN}	-	-9.9	dBm	4
Receiver Sensitivity in OMA	P_{IN}	-	-11.1	dBm	4
Receiver Overload	P_{IN}	-1.0	-	dBm	4
LOS Assert	LOS_A	-25	-	dBm	-
LOS De-Assert	LOS_D	-	-12	dBm	-
LOS Hysteresis	-	1	4	dB	-
Receiver Reflectance	-	-	-12	dB	-

- Notes:**
1. The optical power is launched into SMF.
 2. Measured with a PRBS 2³¹-1 test pattern @10.3125 Gbps.
 3. Reference to Table 52-8 of IEEE P802.3ae
 4. Measured with a PRBS 2³¹-1 test pattern @10.3125 Gbps, BER ≤ 10⁻¹².

Monitoring Specifications

Data Address	Parameter	Range	Accuracy	Notes
96-97	Temperature	-10 to 80 °C	± 3 °C	-
100-101	Bias Current	0 to 15 mA	± 10 %	-
102-103	TX Power	-9 to 0 dBm	± 2 dB	-
104-105	RX Power	-15 to 0 dBm	± 2 dB	-
106-107	V _{CC5} Voltage	4.5 V to 5.5 V	± 3 %	-
108-109	V _{CC3} Voltage	3.0 V to 3.7 V	± 3 %	-

Absolute Maximum Rating

Parameter	Symbol	Min.	Max.	Unit	Notes
Supply Voltage (3.3V)	V _{CC3}	-0.5	4.0	V	-
Supply Voltage (5.0V)	V _{CC5}	-0.5	6.0	V	-
Operating Relative Humidity	RH	-	85	%	-
Storage Temperature	T _s	-40	85	°C	-

Datasheet

Recommended Operation Conditions

Parameter	Symbol	Min	Max	Unit	Notes
Operating Temperature (Case)	T_C	0	70	°C	-
Power Supply Voltage (3.3V)	V_{CC3}	3.13	3.47	V	-
Power Supply Voltage (5V)	V_{CC5}	4.75	5.25	V	-
Power Supply Current (3.3V)	I_{CC3}	-	400	mA	-
Power Supply Current (5V)	I_{CC5}	-	20	mA	-
Power Dissipation	P_D	-	1.5	W	-
Data Rate	DR	9.95	10.3	Gbps	-
Transmission Distance	-	2	300	m	1

Notes: 1. The transmission distance depends on the fiber type. PLS see "Table 52-6" in IEEE 802.3ae.

Electrical Specifications

Parameter	Symbol	Minimum	Maximum	Unit	Notes
High-Speed Signal (CML) Interface Specification					
Input Data Rate	-	9.953	10.3125	Gbps	-
Differential Data Input Amplitude	-	120	1200	mVpp	1
Input Differential Impedance	-	80	120	Ω	-
Output Data Rate	-	9.95	10.3	Gbps	-
Differential Data Output Amplitude	-	500	800	mVpp	1
Output Differential Impedance	-	80	120	Ω	-
Low-Speed Signal (LVTTTL) Interface Specification					
Input High Voltage	-	2.0	$V_{dd1}=3.3$	V	-
Input Low Voltage	-	GND	0.8	V	-
Output High Voltage	-	2.4	$V_{dd1}=3.3$	V	-
Output Low Voltage	-	GND	0.4	V	-
2-Wire Serial Interface (LVTTTL) Specification					
Clock Frequency	f_{SCL}	-	400	kHz	-
Reference Clock Interface Specification					
No Reference Clock Needed					

Notes: 1. Internally AC coupled.

Datasheet

Host Board Connector Legend				
Pin	Logic	Symbol	Name/Description	Note
1		GND	Module Ground	1
2		V _{EE5}	Optional -5.2V power supply (Not Implemented)	
3	LVTTTL-I	Mod_DeSel	Module De-Select; when held low allows module to respond to 2-wire serial interface	
4	LVTTTL-O	$\overline{\text{Interrupt}}$	Interrupt (bar); indicates presence of an important condition which can be read over the 2-wire serial interface	2
5	LVTTTL-I	TX_DIS	Transmitter Disable; turns off transmitter laser output	
6		V _{CC5}	+5 V Power Supply	
7		GND	Module Ground	1
8		V _{CC3}	+3.3 V Power Supply	
9		V _{CC3}	+3.3 V Power Supply	
10	LVTTTL-I/O	SCL	2-Wire Serial Interface Clock	2
11	LVTTTL-I/O	SDA	2-Wire Serial Interface Data Line	2
12	LVTTTL-O	Mod_Abs	Indicates module is not present. Grounded in the module	2
13	LVTTTL-O	Mod_NR	Module Not Ready; indicating module operational fault	2
14	LVTTTL-O	RX_LOS	Receiver Loss of Signal Indicator	2
15		GND	Module Ground	1
16		GND	Module Ground	1
17	CML-O	RD-	Receiver Inverted Data Output	
18	CML-O	RD+	Receiver Non-Inverted Data Output	
19		GND	Module Ground	1
20		V _{CC2}	+1.8 V Power Supply (Not Implemented)	3
21	LVTTTL-I	P_Down/RST	Power Down; When high, requires the module to limit power consumption to 1.5 W or below. 2-wire serial interface must be functional in the low power mode. Reset; the falling edge initiates a complete reset of the module including the 2-wire serial interface, equivalent to a power cycle.	
22		V _{CC2}	+1.8 V Power Supply (Not Implemented)	3
23		GND	Module Ground	1
24	PECL-I	RefCLK+	Not used, internally terminated to 50 ohm (100 ohm diff).	4
25	PECL-I	RefCLK-	Not used, internally terminated to 50 ohm (100 ohm diff).	4
26		GND	Module Ground	1
27		GND	Module Ground	1
28	CML-I	TD-	Transmitter Inverted Data Input	
29	CML-I	TD+	Transmitter Non-Inverted Data Input	
30		GND	Module Ground	1

- Notes:**
1. Module ground pins GND are isolated from the module case and chassis ground within the module.
 2. Shall be pulled up with 4.7 K-10 Kohms to a voltage between 3.15 V and 3.45 V on the host board.
 3. The pins are open within module.
 4. Reference Clock is not required.

Datasheet

Host Board Connector Pinout

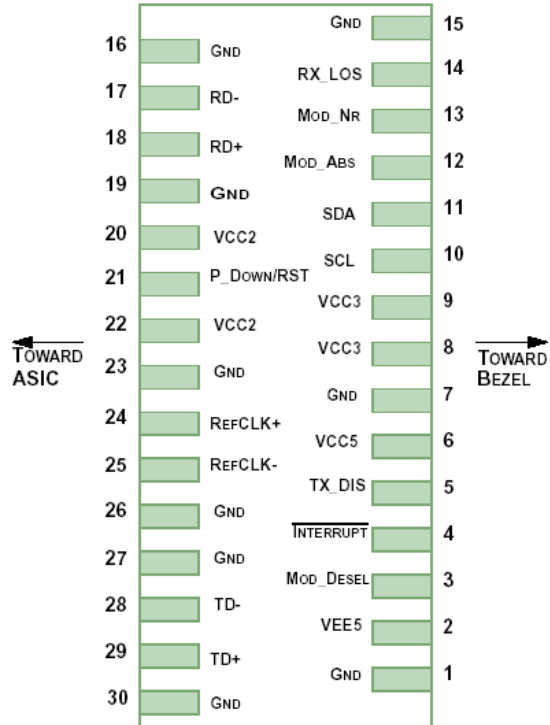

Mechanical Drawing

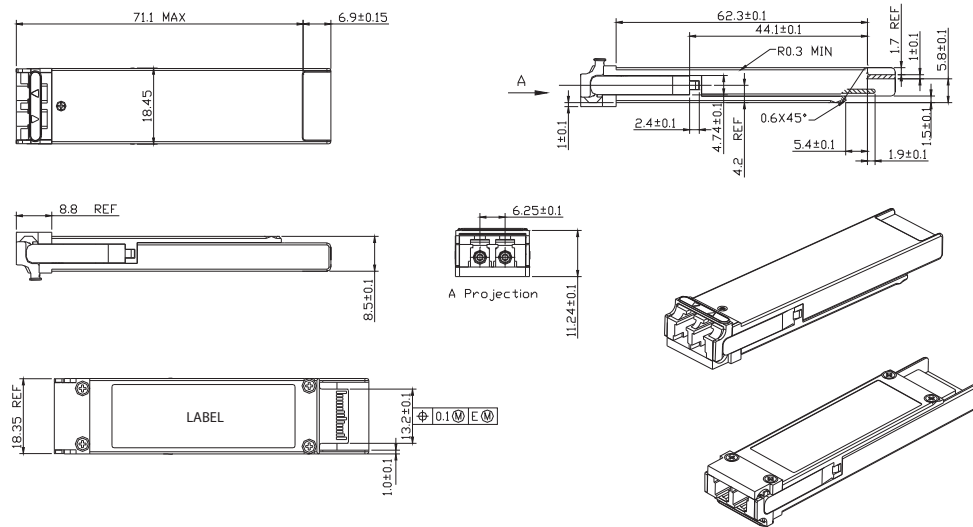



Datasheet

Ordering Information

Model	Description	Data Rate (Gbps)	Wavelength (nm)	Dispersion Penalty (dB)	Bail Latch Color	Distance Range (m)
XFP-10GED-SX	Dual Rate 10 GbE multi-mode XFP transceiver with Digital Diagnostics.	9.953 - 10.3125	850	3.9	Beige	2 - 300

Regulatory and Industry Compliances

Class 1 Laser Product, complies with EN 60825-1 and 21 CFR 1040.10 except for deviations pursuant to Laser Notice No. 50. dated June 24, 2007
MSA INF-8077i; IEEE802.3ae-2002; Digital Diagnostic SFF-8472
Certified by one or more of the following agencies: TÜV, UL, CSA
RoHS Directive; China RoHS; California RoHS Law, REACH Directive SVHC; WEEE Directive
The Quality Management System is certified to ISO 9001 by QMI-SAI Global
The Environmental Management System is in compliance with ISO 14001

Warnings

Handling Precautions: This device is susceptible to damage as a result of electrostatic discharge (ESD). A static free environment is highly recommended. Follow guidelines according to proper ESD procedures.

Laser Safety: Radiation emitted by laser devices can be dangerous to human eyes. Avoid eye exposure to direct or indirect radiation.

MRV has more than 50 offices throughout the world. Addresses, phone numbers and fax numbers are listed at www.mrv.com. Please e-mail us at info@mrv.com or call us for assistance.

MRV Los Angeles
20415 Nordhoff Street
Chatsworth, CA 91311
800-338-5316
818-773-0900

MRV Boston
300 Apollo Drive
Chelmsford, MA 01824
800-338-5316
978-674-6800

MRV International
Business Park Moerfelden
Waldeckerstrasse 13
64546 Moerfelden-Walldorf
Germany
Tel. (49) 6105/2070
Fax (49) 6105/207-100

All statements, technical information and recommendations related to the products herein are based upon information believed to be reliable or accurate. However, the accuracy or completeness thereof is not guaranteed, and no responsibility is assumed for any inaccuracies. Please contact MRV Communications for more information. MRV Communications and the MRV Communications logo are trademarks of MRV Communications, Inc. Other trademarks are the property of their respective holders.