

Datasheet

10GBASE-CX4 Copper XFP Transceiver

XFP-CX4



Overview

The XFP-CX4 copper transceiver from MRV Communications provides cost-effective and reliable bandwidth transport of up to 12.5 Gigabits over distances of up to 15 meters. The product provides 4 full-duplex, 3.125 Gigabaud transmit and receive channels over a single parallel copper cable that is transparent to the user. It not only offers the ability to scale net bandwidth in 10 Gigabit increments, it also mates directly with the industry standard MDI electrical socket.

The XFP-CX4 is ideal for telecom central office and enterprise data center applications. Whether extending bandwidth in-system or inter-connecting between systems, the XFP-CX4 transceiver offers an attractive combination of high performance and low cost in an industry standard form factor.

Highlights

- 10GBASE-CX4 compliant (IEEE 802.3ak)
- **15 meters reach on appropriate CX4-grade copper cable** -- 4-channel full-duplex copper cable support
- MSA compatible form factor (XFP)
- XFI high-speed host electrical interface
- Serial two-wire interface with SCL/SDA lines
- Z-axis front panel pluggable
- 30-pin host connector
- MDI socket for CX4, Infiniband, and Fibre Channel compatibility
- XFP power level 2 compliance
- Hot-pluggable electronics
- 0°C to 70°C case temperature operating range
- RoHS 5/6 Compliance

Applications

- 10 Gigabit Ethernet
- Enterprise routers
- Workgroup routers and switches
- Servers
- NIC cards
- Storage interfaces
- Supercomputers

Absolute Maximum Ratings

Parameter	Symbol	Min.	Max.	Units	Notes
Storage Temperature	T_s	-20	100	°C	1
Supply Voltage (3.3 V)	Vcc3	-0.5	3.6	V	1
Supply Voltage (1.8 V)	Vcc2	-0.5	2.0	V	1
CMOS Data Input Voltage	V_I	-0.3	$V_{CCA}+0.3$	V	1
CML Output Current	I_D	-50	50	mA	1
Relative Humidity	RH	5	95	%	1, 2

- Notes:**
1. Exceeding the absolute maximum ratings can permanently damage the module.
 2. Non condensing. Not intended for applications requiring aqueous wash.

Datasheet

Recommended Operating Conditions

Parameter	Symbol	Min.	Max.	Units	Notes
Operating Case Temperature	T_c	+0	+70	°C	-
Supply Voltage (3.3 V)	Vcc3	3.14	3.47	V	±5%
Power Supply Rejection	PSR	-	200	mV _{p-p}	1
Supply Voltage (1.8 V)	Vcc2	1.71	1.89	V	±5%
Signaling Rate	-	-	10.3125	GBd	2
Clock Skew (from 10.3125 Gbps)	-	-	100	ppm	-
SCL Clock Rate	SCL	-	400	kHz	-
SCL/SDA I/O Voltage (LVTTTL) (host pull to 3.3 V)	V_L / V_H	-0.3 / Vcc3*0.7	Vcc3*0.3 / Vcc3+0.5	V	-
Serial Data Input Termination Differential	R_{DL}	-	100	Ohm	3

- Notes:**
1. Tested with 200 mV_{p-p} broadband noise in the frequency range from 44 kHz to 400 MHz on the 3.3V Vcc supply.
 2. Limited to 10 gb/s ethernet LAN data.
 3. The high-speed serial transmitter's data inputs are internally terminated for use with external transmission lines that have a characteristic impedance of $Z_o = 100$ Ohms differential.

Electrical Characteristics, General

Parameter	Symbol	Min.	Max.	Units	Notes
Supply Voltage (3.3 V)	Vcc3	3.14	3.47	V	-
Supply Current (3.3 V)	Icc3	-	100	mA	-
Supply Voltage (1.8 V)	Vcc2	1.71	1.89	V	-
Supply Current (1.8 V)	Icc2	-	500	mA	-
Power Dissipation	P_{DIST}	-	2.0	W	-
TX_Dis, P_Down/RST Voltage	V_L / V_H	-0.3 / 2.0	0.8 / Vcc3+0.3	V	-
RX_Los, Mod_NR, Interrupt	V_L / V_H	0 / Host_Vcc-0.5	0.40 / Host_Vcc+0.31	V	-
P_Down Reset Time	-	10	-	µs	-

Electrical Receiver Specifications

Parameter	Symbol	Min.	Max.	Units	Notes
Cable Type	Standard 4 channel CX4 cable				-
Connector Durability	100	-	-	-	1
Connector Style	Industry standard MDI copper connector				-

- Notes:**
1. Insertions/extractions

Datasheet

Electrical Receiver Characteristics (Cable Side, CX4 Side)

Parameter	Symbol	Min.	Max.	Units	Notes
Receiver Differential Input Voltage	V_{in}	100	2000	mV _{p-p}	1
Deterministic Jitter Tolerance	DJ	0.65	-	UI	2
Total Jitter Tolerance	TJ	0.75	-	UI	-

- Notes:**
- $V_{in} = [(V_{in+p-p}) - (V_{in-p-p})]$
 - If the incoming DJ is caused by copper cable then it can be compensated by equalization in the receiver. In this case the DJ tolerance could be as high as 1UI.

Electrical Transmitter Characteristics (Cable Side, CX4 Side)

Parameter	Symbol	Min	Max	Unit	Notes
Differential Peak-to-Peak Output Voltage Swing	V_{out}	800	1200	mV	1
Differential Voltage Difference (lane to lane)	V_{out}	-	175	mV	-
Common Mode Output Voltage	V_{com}	0.5	1.0	V	-
Data Output Rise Time (20%/80%)	t_r	60	130	ps	2
Data Output Fall Time (80%/20%)	t_f	60	130	ps	2
Deterministic Jitter	DJ	-	0.17	UI	-
Total Jitter	TJ	-	0.35	UI	-
Vcc for Active Module (when active module present)	Vcc	3.15	3.46	V	-
Resistor attached to type_sense for turning on power to active module	R_{type_sense}	-	5.1	KOhm	-

- Notes:**
- $V_{out} = [(V_{out+p-p}) - (V_{out-p-p})]$
 - Power will not be supplied to that pin if a copper cable or any module without a resistor of proper value attached to the type_sense pin. The resistor should be 5.1K ± 10%

Signal Description (Cable Side, CX4 Side)

Signal	Functional Description
GND	Circuit ground. Connect these pins to the host system's circuit common ground plane.
Vcc	Power supply provides +3.3 VDC when an active module (QTR3400) is plugged into the socket. Output is AC ground when a regular copper cable is present.
TX0+ through TX3+	CML compatible transmitter data out+ for channels 0 through 3, respectively.
TX0- through TX3-	CML compatible transmitter data out- for channels 0 through 3, respectively.
RX0+ through RX3+	CML compatible transmitter data in+ for channels 0 through 3, respectively.
RX0- through RX3-	CML compatible transmitter data in- for channels 0 through 3, respectively.
ODIS	Used to control the active module. Grounded in this CX4 implementation.
Type_Sense	Used to determine whether or not active module is present. It is an AC ground.
Fault	Transmitter Fault signal or Loss signal from receiver side. Grounded in this CX4 implementation.

Datasheet
Electrical Pin Map (Cable Side, CX4 Side)

SFF-8470 MDI Connector Function	Active Module Pin Assignment
G1	GND
G2	ODIS
G3	GND
G4	GND
G5	GND
G6	Fault
G7	Type_Sense
G8	Vcc
G9	GND
S1	RX0+
S2	RX0-
S3	RX1+
S4	RX1-
S5	RX2+
S6	RX2-
S7	RX3+
S8	RX3-
S9	TX3-
S10	TX3+
S11	TX2-
S12	TX2+
S13	TX1-
S14	TX1+
S15	TX0-
S16	TX0+
Housing	Chassis Ground

Note:

The cable side pin assignment is compatible with the Fibre Channel standard proposal (PI-2) that supports active modules. When a copper cable is plugged in, then all G_signals are ground.

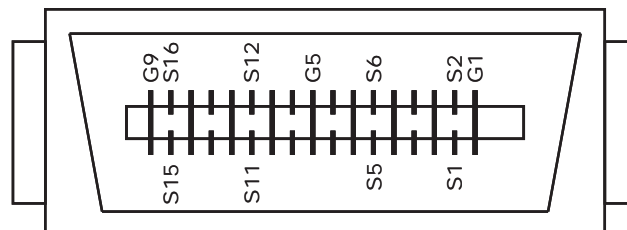
Electrical Pin Map (Cable Side, CX4 Side)

Front-View CX4 Connector

Datasheet
Electrical Pin Map, Host Side, XFI Side, Bottom Side of Board

Pin	Logic	Name	Functional Description	Notes
1	-	GND	Module Ground	1
2	VEE5	Optional	-5.2 V power supply	-
3	LVTTTL-I	Mod_DeSel	Module De-select; When held low allows module to respond to 2-wire serial interface	-
4	LVTTTL-O	Interrupt_N	Indicates presence of an important condition which can be read over the 2-wire serial interface	2
5	LVTTTL-I	TX_DIS	Transmitter Disable; Turns off transmitter laser output	-
6	VCC5	+5 V	Power supply	-
7	-	GND	Module Ground	1
8	-	Vcc3	+3.3 V Power Supply	-
9	-	Vcc3	+3.3 V Power Supply	-
10	LVTTTL-I/O	SCL	2-Wire Serial Interface Clock	2
11	LVTTTL-I/O	SDA	2-Wire Serial Interface Data Line	2
12	LVTTTL-O	Mod_Abs	Indicates module is not present. Grounded in the module	2
13	LVTTTL-O	Mod_NR	Module Not Ready; Indicating module operational fault	2
14	LVTTTL-O	RX_LOS	Receiver Loss of Signal Indicator	2
15	-	GND	Module Ground	1
16	-	GND	Module Ground	1
17	CML-O	RD_N	Receiver Inverted Data Output	-
18	CML-O	RD_P	Receiver Non-Inverted Data Output	-
19	-	GND	Module Ground	1
20	-	Vcc2	+1.8 V Power Supply	-
21	LVTTTL-I	P_Down/RST	Power Down; When high, requires the module to limit power consumption to 1.5 W or below. 2-wire serial interface must be functional in the low power mode. Reset; The falling edge initiates a complete reset of the module including the 2-wire serial interface, equivalent to a power cycle.	-
22	-	Vcc2	+1.8 V Power Supply	-
23	-	GND	Module Ground	1
24	PECL-I	RefCLK_N	Reference Clock Non-Inverted Input, AC coupled on the host board	-
25	PECL-I	RefCLK_P	Reference Clock Inverted Input, AC coupled on the host board	-
26	-	GND	Module Ground	1
27	-	GND	Module Ground	1
28	CML-I	TD_N	Transmitter Inverted Data Input	-
29	CML-I	TD_P	Transmitter Non-Inverted Data Input	-
30	-	GND	Module Ground	1

- Notes:**
1. XFP-CX4 module ground pins are isolated from the module case ground.
 2. Must be pulled up with 4.7 K-10 KOhms to a voltage between 3.15 V and 3.45 V on the host board.

Datasheet

Electrical Pin Map, Host Side, XFI Side

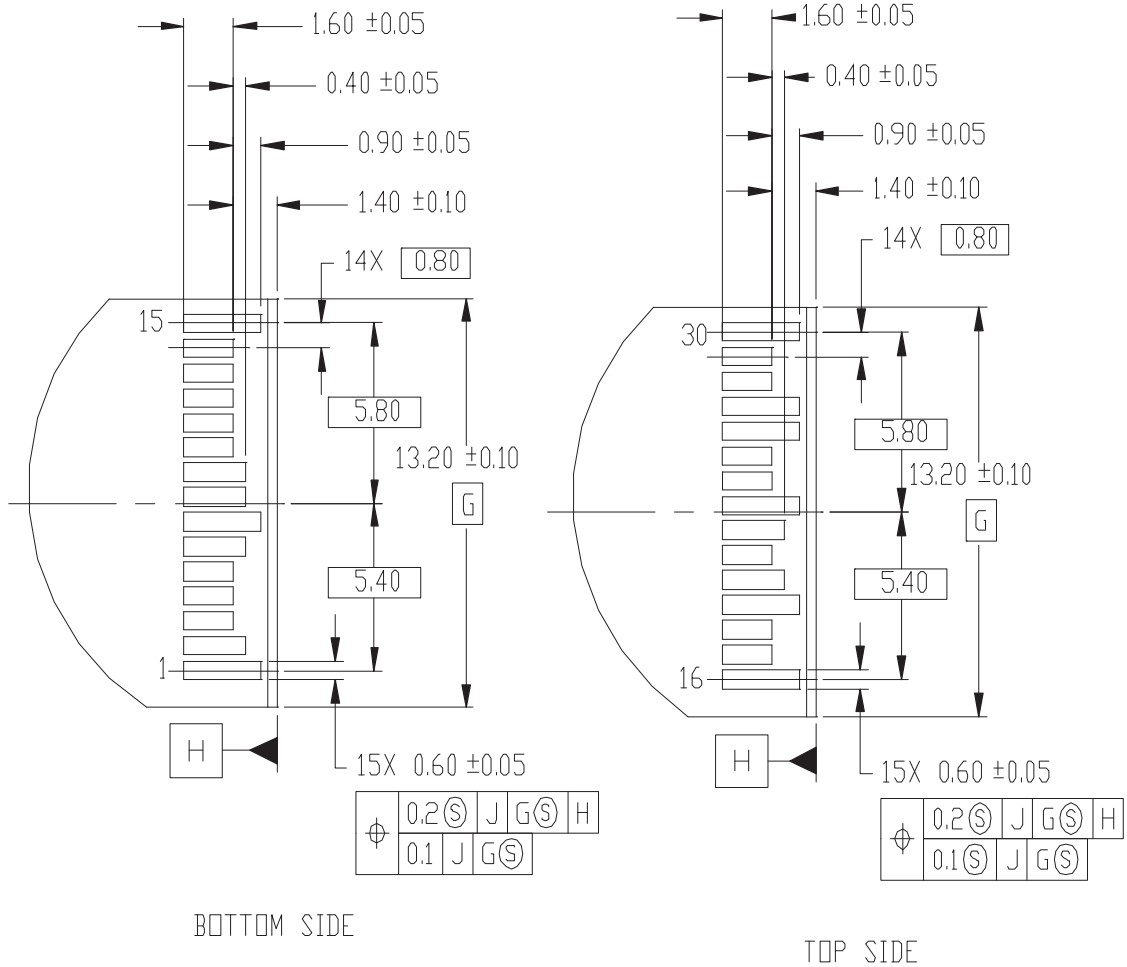

Datasheet

Module Outline Dimensions, in mm

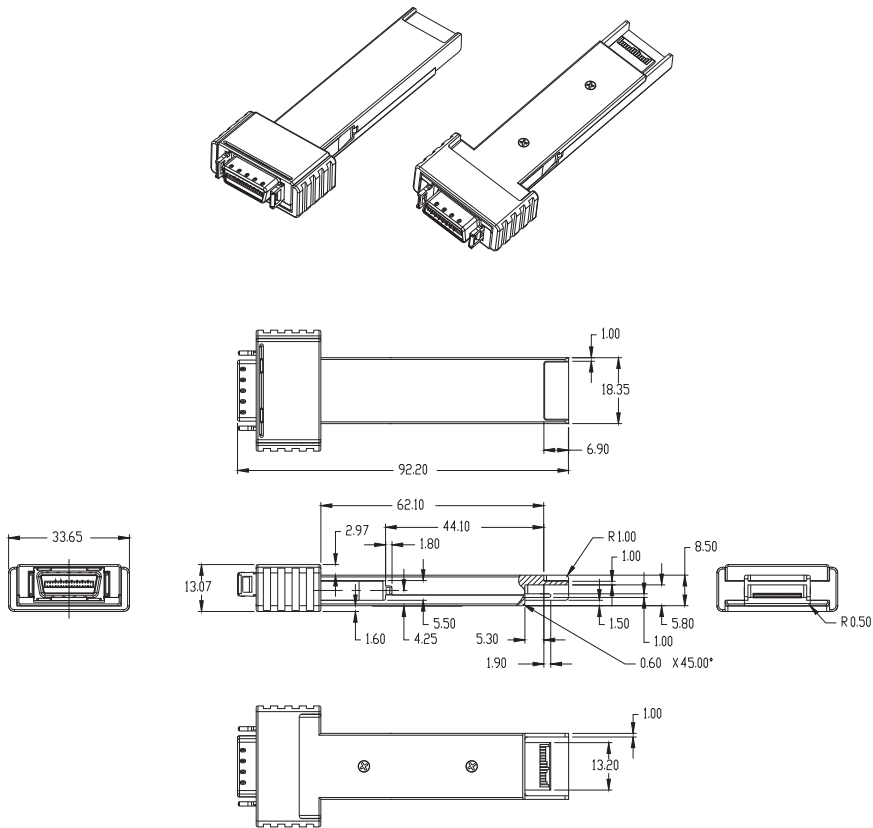

Ordering Information

Model	Description	Data Rate (Gbps)	Distance (m)
XFP-CX4	10 GbE -CX4 Copper XFP Transceiver	Up to 12.5	15

MRV has more than 50 offices throughout the world. Addresses, phone numbers and fax numbers are listed at www.mrv.com. Please e-mail us at info@mrv.com or call us for assistance.

MRV Los Angeles
20415 Nordhoff Street
Chatsworth, CA 91311
800-338-5316
818-773-0900

MRV Boston
300 Apollo Drive
Chelmsford, MA 01824
800-338-5316
978-674-6800

MRV International
Business Park Moerfelden
Waldeckerstrasse 13
64546 Moerfelden-Walldorf
Germany
Tel. (49) 6105/2070
Fax (49) 6105/207-100

All statements, technical information, and recommendations related to the products herein are based upon information believed to be reliable or accurate. However, the accuracy or completeness thereof is not guaranteed, and no responsibility is assumed for any inaccuracies. Please contact MRV Communications for more information. MRV Communications and the MRV Communications logo are trademarks of MRV Communications, Inc. Other trademarks are the property of their respective holders.