

**Datasheet**

**Tunable DWDM Multi-Rate 80 km XFP Transceiver**

XFP-DWLR08TC



**Features**

- Tunable XFP transceiver
- C-band wavelengths (with 50 GHz DWDM ITU grid)
- Data Rates: 9.95 - 11.35 Gbps
- Protocols:
  - 10 Gbps Ethernet
  - 10 Gbps Ethernet with FEC
  - 10 Gbps Fibre Channel
  - 10 Gbps Fibre Channel with FEC
  - SONET OC-192/STM-64
  - SONET OC-192/STM-64 with FEC
- Single-mode fiber
- 40 to 80 km
- Duplex LC connector
- Digital Diagnostics (SFF-8472)
- XFI Loopback
- Hot-swap

**Overview**

MRV Communications’ XFP transceivers provide the high speeds and compact dimensions that today’s demanding networks require while delivering the deployment flexibility and inventory control that network administrators demand. Designed to Multi-Source Agreement (MSA) standards for broadest compatibility, they perfectly match MRV’s wide range of optical transport solutions.

Visit the MRV website at [www.mrv.com](http://www.mrv.com) or contact your nearest authorized MRV Communications dealer for more information.

<b>Specifications Overview</b>	
Data Rate	9.95 - 11.35 Gbps
Tx Wavelength	Tunable from 1528.384 to 1568.773 nm (with 50 GHz DWDM ITU grid)
Dispersion Tolerance	1600 ps/nm
Tx Power (Minimum)	-1 dBm
Tx Disable	Yes
Rx Wavelength	1260 - 1600 nm
Rx Sensitivity(EOL)	-24 dBm
Rx Saturation	-7 dBm
Damage Threshold	3 dBm
Operating Temperature Range	-5 to 70°C
Power Consumption (Maximum)	3.5 Watts

## Datasheet

### Transmitter Specifications (Optical)

Parameter	Symbol	Min	Max	Unit	Notes
Average Optical Power (EOL)	$P_{avg}$	-1	3	dBm	-
Extinction Ratio	ER	9	-	dB	1
Wavelength Range	$\lambda_c$	1528.384	1568.773	nm	ITU Grid
Frequency Range	-	191.1	196.15	THz	ITU Grid
Channel Spacing	-	50	-	GHz	-
Wavelength Stability (BOL)	-	$\lambda_c - 1.5$	$\lambda_c + 1.5$	GHz	-
Wavelength Stability (EOL)	-	$\lambda_c - 2.5$	$\lambda_c + 2.5$	GHz	-
Sidemode Suppression Ratio	SMSR	35	-	dB	-
Relative Intensity Noise	RIN	-	-130	dB/Hz	-
Optical Path Penalty ( $\leq 9.95$ Gbps)	$P_{PATH}$	-	2	dB	2
Optical Path Penalty (up to 10.709 Gbps)	$P_{PATH}$	-	2.5	dB	2, 3
Optical Path Penalty (up to 11.35 Gbps)	$P_{PATH}$	-	3	dB	2, 3
Return Loss Tolerance	-	-	27	dB	-

- Note:**
1. Tested with PRBS 2<sup>31</sup> – 1 pattern
  2. Optical path penalty is applicable at +1600 ps/nm and -400ps/nm chromatic dispersion
  3. Measured at BER < 10<sup>-6</sup>; PRBS 2<sup>31</sup> – 1 pattern

### Receiver Specifications (Optical)

Parameter	Symbol	Min	Max	Unit	Notes
Center Wavelength	$\lambda$	1260	1600	nm	-
Receiver Sensitivity (EOL)	$R_{SEN}$	-	-24	dBm	1, 2
Receiver Overload	$P_{MAX}$	-7	-	dBm	3
Receiver Reflectance	$R_{RX}$	-	-27	dB	-
LOS Assert	$P_{los\_on}$	-	-26	dBm	-
LOS De-assert	$P_{los\_off}$	-	-30	dBm	-
LOS Hysteresis	-	0.5	4	dB	-

- Note:**
1. Guaranteed at 10.709 Gbps. Measured with worst ER; BER < 10<sup>-12</sup>; PRBS 2<sup>31</sup> – 1 pattern
  2. Guaranteed at 11.35 Gbps. Measured with worst ER; BER < 10<sup>-4</sup>; PRBS 2<sup>31</sup> – 1 pattern
  3. Guaranteed up to 10.709 Gbps

### Absolute Maximum Rating

Parameter	Symbol	Min.	Max.	Unit	Notes
Maximum Supply Voltage (5.0V)	$V_{cc5}$	-0.5	6.0	V	-
Maximum Supply Voltage (3.3V)	$V_{cc3}$	-0.5	3.63	V	-
Maximum Supply Voltage (1.8.0V)	$V_{cc2}$	-0.5	1.98	V	-
Storage Temperature	$T_{ST}$	-40	85	°C	-
Operating Case Temperature	$T_{OP}$	-5	70	°C	-
Relative Humidity (Non-Condensing)	RH	5	85	%	-
Static Electrical Discharge (Human Body Model)	ESD	-	500	V	-
Receive Input Optical Power (Damage Threshold)	$P_{dth}$	-	3	dBm	-

**Datasheet**
**Electical Specifications**

Parameter	Symbol	Min	Max	Unit	Notes
<b>Supply Currents and Voltages</b>					
Voltage5	Vcc5	4.75	5.25	V	1
Voltage3	Vcc3	3.13	3.47	V	1
Voltage2	Vcc2	1.71	1.89	V	1
Supply Current5	Icc5	-	750	mA	-
Supply Current3	Icc3	-	500	mA	-
Supply Current2	Icc2	-	1000	mA	-
Power Dissipation	Pwr	-	3.5	W	-
<b>Low Speed Control and Sense Signals (Detailed Specification in XFP MSA INF8077i Rev. 4.5)</b>					
Outputs (Interrupt, Mod_NR, RX_LOS)	V <sub>OL</sub>	0	0.4	V	2
	V <sub>OH</sub>	host_Vcc - 0.5	host_Vcc + 0.3	V	3
Inputs (TX_DIS, P_Down/RST, M_DSEL)	V <sub>IL</sub>	-0.3	0.8	V	4
	V <sub>IH</sub>	2	Vcc3 + 0.3	V	4
SCL and SDA Inputs	V <sub>IL</sub>	-0.3	Vcc3 * 0.3	-	5
	V <sub>IL</sub>	Vcc3 * 0.7	Vcc3 + 0.5	-	5
<b>Transmitter Input (Detailed Specification in XFP MSA INF8077i Rev. 4.5)</b>					
Data Input Baud Rate Nominal	-	9.95	11.35	Gbps	-
Data Input Bit Rate Tolerance (10GbE / 10GFC)	-	-100	100	ppm	-
Data Input Bit Rate Tolerance (SONET / SDH)	-	-20	20	ppm	-
Data Input Compliance	-	B (See XFP MSA INF8077i Rev. 4.5)			6
Data Input Differential Impedance	R <sub>I</sub>	90	110	Ω	-
<b>Receiver Output (Detailed Specification in XFP MSA INF8077i Rev. 4.5)</b>					
Data Output Baud Rate Nominal	-	9.95	11.35	Gbps	-
Data Input Compliance	-	C (See XFP MSA INF8077i Rev. 4.5)			6
Data Output Bit Rate Stability (10GbE / 10GFC)	-	-100	100	ppm	-
Data Output Bit Rate Stability (SONET / SDH)	-	-20	20	ppm	-

- Note:**
1. With Respect to GND
  2. Rpullup pulled to host\_Vcc, measured at host side of connector. I<sub>OL</sub>(max) = 3 mA.
  3. Rpullup pulled to host\_Vcc, measured at host side of connector.
  4. Pulled up in module to Vcc3.
  5. Rpullup pulled to host\_Vcc, measured at XFP side of connector
  6. Internally AC coupled signals

## Datasheet

### Jitter Specifications

Parameter	Symbol	Min	Max	Unit	Notes
<b>Transmitter Electrical Input Jitter from Host at B (Detailed Specification in XFP MSA INF8077i Rev. 4.5)</b>					
Total Non-EQJ Jitter	-	-	0.41	UI(p-p)	1
Total Jitter	TJ	-	0.61	UI(p-p)	-
Eye Mask	X1	-	0.305	UI	2
Eye Mask	Y1	60	-	mV	-
Eye Mask	Y2	-	410	mV	3
<b>Receiver Electrical Output Jitter to Host at C (Detailed Specification in XFP MSA INF8077i Rev. 4.5)</b>					
Deterministic Jitter	DJ	-	0.18	UI(p-p)	4
Total Jitter	TJ	-	0.34	UI(p-p)	4
Eye Mask	X1	-	0.17	UI	-
Eye Mask	X2	-	0.42	UI	-
Eye Mask	Y1	170	-	mV	-
Eye Mask	Y2	-	425	mV	-
Jitter Transfer Bandwidth	BW	-	8	MHz	5
Jitter Peaking	-	-	1	dB	6
Transmitter Jitter Generation	-	-	0.3	UI(p-p)	7
	-	-	0.1	UI(p-p)	8

- Note:**
1. Total jitter less ISI
  2. Mask coordinate X1 = 0.205 if total non-DDJ is measured
  3. 50 mV is allocated for multiple reflections.
  4. Includes jitter transferred from the optical receiver during any valid operational input condition.
  5. PRBS 2<sup>31</sup> - 1, OC-192 / SDH-64 Sinusoidal Jitter Tolerance Mask
  6. Frequency > 120 KHz
  7. 20 KHz to 80 MHz
  8. 4 MHz to 80 MHz

### Timing Requirement of Control and Status I/O

Parameter	Symbol	Min	Max	Unit	Notes
TX_DIS Assert Time	t_off	-	10	µsec	1
TX_DIS Negate Time	t_on	-	2	msec	2
Time to Initialize	t_init	-	300	msec	3
Interrupt Assert Delay	Interrupt_on	-	200	msec	4
Interrupt Negate Delay	Interrupt_off	-	500	µsec	5
P_Down/RST Assert Delay	P_Down/RST_on	-	100	µsec	6
Mod_NR Assert Delay	Mod_NR_on	-	1	msec	7
Mod_NR Negate Delay	Mod_NR_off	-	1	msec	8
P-Down Reset Time	-	10	-	µsec	9
RX_LOS Assert Delay	t_loss_on	-	100	µsec	10
RX_LOS Negate Delay	t_loss_off	-	100	µsec	11

- Note:**
1. Rising edge of TX\_DIS to fall of output signal below 10% of nominal
  2. Falling edge of TX\_DIS to rise of output signal above 90% of nominal
  3. From power on or from falling edge of P\_Down/RST
  4. From occurrence of the condition triggering Interrupt
  5. From clear on read Interrupt flags
  6. From power down initiation
  7. From occurrence of fault to assertion of Mod\_NR
  8. From clearance of signal to negation of Mod\_NR
  9. Minimum length of P-Down assert to initiate reset
  10. From Occurrence of loss of signal to assertion of RX\_LOS. The RX\_LOS assert time can be 200 µsec max when the optical input power is greater than -15 dBm immediately prior to the RX\_LOS condition.
  11. From Occurrence of return of signal to negation of RX\_LOS

## Datasheet

### Pin Out Definition

Pin	Logic	Symbol	Name/Description	Note
1	-	GND	Module Ground	1
2	-	Vee5	Optional -5.2 V power supply (not required)	-
3	LVTTTL-I	Mod_DeSel	Module De-Select; When held low allows module to respond to 2-wire serial interface	-
4	LVTTTL-O	Interrupt	Interrupt (bar); Indicates presence of an important condition which can be read over the 2-wire serial interface	2
5	LVTTTL-I	TX_DIS	Transmitter Disable; Transmitter laser source turned off	-
6	-	Vcc5	+5 V Power Supply	-
7	-	GND	Module Ground	1
8	-	Vcc3	+3.3 V Power Supply	-
9	-	Vcc3	+3.3 V Power Supply	-
10	LVTTTL-I	SCL	2-Wire Serial Interface Clock	2
11	LVTTTL-I/O	SDA	2-Wire Serial Interface Data Line	2
12	LVTTTL-O	Mod_Abs	Module Absent; Indicates module is not present. Grounded in the module	2
13	LVTTTL-O	Mod_NR	Module Not Ready; Indicating Module Operational Fault	2
14	LVTTTL-O	RX_LOS	Receiver Loss of Signal Indicator	2
15	-	GND	Module Ground	1
16	-	GND	Module Ground	1
17	CML-O	RD-	Receiver Inverted Data Output	-
18	CML-O	RD+	Receiver Non-Inverted Data Output	-
19	-	GND	Module Ground	1
20	-	Vcc2	+1.8 V Power Supply	-
21	LVTTTL-I	P_Down/RST	Power down; When high, the module limits power consumption to 1.5 W or below. Serial interface is functional in the low power mode. Reset; The falling edge initiates a complete reset of the module including the serial interface, equivalent to a power cycle.	-
22	-	Vcc2	+1.8 V Power Supply	-
23	-	GND	Module Ground	1
24	PECL-I	RefCLK+	Reference Clock Non-Inverted Input (Not Used)	-
25	PECL-I	RefCLK-	Reference Clock Inverted Input (Not Used)	-
26	-	GND	Module Ground	1
27	-	GND	Module Ground	1
28	CML-I	TD-	Transmitter Inverted Data Input	-
29	CML-I	TD+	Transmitter Non-Inverted Data Input	-
30	-	GND	Module Ground	1

- Note:**
1. Module ground pins (GND) are isolated from the module case and chassis ground within the module.
  2. Shall be pulled up with 4.7 kΩ – 10 kΩ to a voltage between 3.15 V and 3.45 V on the host board.

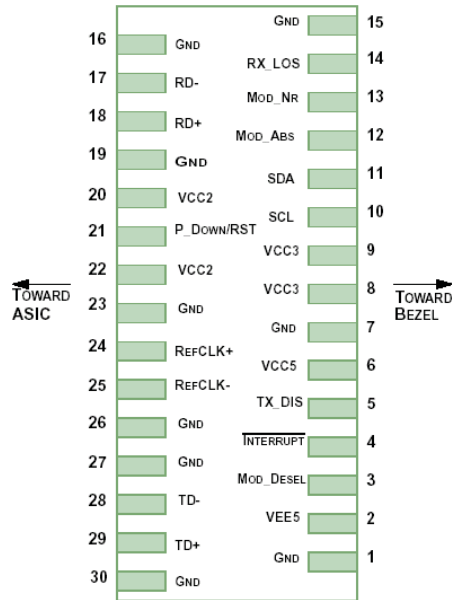
**Datasheet**
**Host Board Connector Pinout**

**λc Wavelength Guide at 100 GHz Spacing\***

ITU Channel (xx)	Frequency (THz)	Wavelength (nm)	ITU Channel (xx)	Frequency (THz)	Wavelength (nm)
11	191.1	1568.77	37	193.7	1547.72
12	191.2	1567.95	38	193.8	1546.92
13	191.3	1567.13	39	193.9	1546.12
14	191.4	1566.31	40	194.0	1545.32
15	191.5	1565.50	41	194.1	1544.53
16	191.6	1564.68	42	194.2	1543.73
17	191.7	1563.86	43	194.3	1542.94
18	191.8	1563.05	44	194.4	1542.14
19	191.9	1562.23	45	194.5	1541.35
20	192.0	1561.42	46	194.6	1540.56
21	192.1	1560.61	47	194.7	1539.77
22	192.2	1559.79	48	194.8	1538.98
23	192.3	1558.98	49	194.9	1538.19
24	192.4	1558.17	50	195.0	1537.40
25	192.5	1557.36	51	195.1	1536.61
26	192.6	1556.55	52	195.2	1535.82
27	192.7	1555.75	53	195.3	1535.04
28	192.8	1554.94	54	195.4	1534.25
29	192.9	1554.13	55	195.5	1533.47
30	193.0	1553.33	56	195.6	1532.68
31	193.1	1552.52	57	195.7	1531.90
32	193.2	1551.72	58	195.8	1531.12
33	193.3	1550.92	59	195.9	1530.33
34	193.4	1550.12	60	196.0	1529.55
35	193.5	1549.32	61	196.1	1528.77
36	193.6	1548.51			

\* For 50 GHz XFP spacing tunability support, contact your MRV sale representative.

## Datasheet

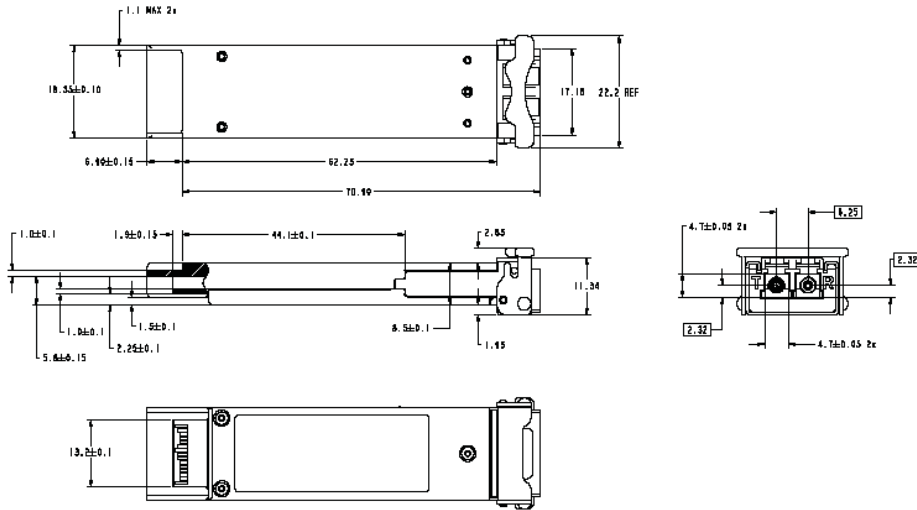
### Mechanical Drawing



### Ordering Information

Model	Description	Data Rate (Gbps)	Wave-length (nm)	Dispersion Tolerance (ps/nm)	Distance Range (km)
XFP-DWLR08TC	10 Gbps single-mode tunable multi-rate DWDM XFP transceiver with Digital Diagnostics.	9.95 - 11.35	C-Band (with 50 GHz ITU grid)	1600	40 - 80

### Regulatory and Industry Compliances

Class 1 Laser Product, complies with EN 60825-1 and 21 CFR 1040.10 except for deviations pursuant to Laser Notice No. 50, dated June 24, 2007  
 MSA INF-8077i; Telcordia GR-468; Digital Diagnostic SFF-8472; Telcordia GR-253-CORE; ITU-T G.691; IEEE 802-3ae-2002; 10GFC 1200-SM-LL-L  
 Certified by one or more of the following agencies: TÜV, UL, CSA  
 RoHS Directive; China RoHS; California RoHS Law, REACH Directive SVHC; WEEE Directive  
 The Quality Management System is certified to ISO 9001 by QMI-SAI Global  
 The Environmental Management System is in compliance with ISO 14001

### Warnings

**Handling Precautions:** This device is susceptible to damage as a result of electrostatic discharge (ESD). A static free environment is highly recommended. Follow guidelines according to proper ESD procedures.

**Laser Safety:** Radiation emitted by laser devices can be dangerous to human eyes. Avoid eye exposure to direct or indirect radiation.

MRV has more than 50 offices throughout the world. Addresses, phone numbers and fax numbers are listed at [www.mrv.com](http://www.mrv.com). Please e-mail us at [info@mrv.com](mailto:info@mrv.com) or call us for assistance.

MRV Los Angeles  
 20415 Nordhoff Street  
 Chatsworth, CA 91311  
 800-338-5316  
 818-773-0900

MRV Boston  
 300 Apollo Drive  
 Chelmsford, MA 01824  
 800-338-5316  
 978-674-6800

MRV International  
 Business Park Moerfelden  
 Waldeckerstrasse 13  
 64546 Moerfelden-Walldorf  
 Germany  
 Tel. (49) 6105/2070  
 Fax (49) 6105/207-100

All statements, technical information and recommendations related to the products herein are based upon information believed to be reliable or accurate. However, the accuracy or completeness thereof is not guaranteed, and no responsibility is assumed for any inaccuracies. Please contact MRV Communications for more information. MRV Communications and the MRV Communications logo are trademarks of MRV Communications, Inc. Other trademarks are the property of their respective holders.