

Datasheet

Multi-Rate (10 Gbps) 80 km DWDM XFP Transceivers

XFP-DWLR08-xx



Highlights

- XFP transceiver
- C-band wavelengths on the 100GHz DWDM ITU grid
- Data Rates: 9.95 - 10.7 Gbps
- Protocols:
 - 10 Gbps Ethernet
 - 10 Gbps Fibre Channel
 - SONET OC-192/STM-64
 - SONET OC-192/STM-64 with FEC
- Single-mode fiber
- 40 to 80 km
- Duplex LC connector
- Digital Diagnostics (SFF-8472)
- XFI Loopback
- Hot-swap

Overview

MRV Communications' XFP transceivers provide the high speeds and compact dimensions that today's demanding networks require while delivering the deployment flexibility and inventory control that network administrators demand. Designed to Multi-Source Agreement (MSA) standards for broadest compatibility, they perfectly match MRV's wide range of optical transport solutions.

Visit the MRV website at www.mrv.com or contact your nearest authorized MRV Communications dealer for more information.

Specifications Overview	
Data Rate	9.95 - 10.7 Gbps
Tx Wavelength	See Wavelength Guide
Tx Power (Minimum)	-1 dBm
Dispersion Tolerance	1450 ps/nm
Tx Disable	Yes
Rx Wavelength	1270 - 1600 nm
Rx Sensitivity @ 9.95 Gbps	-24 dBm
Rx Sensitivity @ 10.7 Gbps with FEC	-25 dBm
Rx Saturation	-7 dBm
Damage Threshold	-4 dBm
Operating Temperature Range	-5 to 70°C
Power Consumption (Maximum)	3.5 Watts

Datasheet

Transmitter Specifications (Optical)

Parameter	Symbol	Min	Max	Unit	Notes
Output Power	P _{OUT}	-1	3	dBm	-
Extinction Ratio	ER	8.2	-	dB	-
Transmitter Center Wavelength – End Of Life	λ_C	x - 100	x + 100	pm	1
Transmitter Center Wavelength – Beginning Of Life	λ_C	x - 50	x	pm	1
Sidemode Suppression Ratio	SSR _{min}	30	-	dB	-
Jitter Generation (Peak-to-Peak)	T _{Xj}	-	0.1	UI	2
Jitter Generation (RMS)	T _{XjRMS}	-	0.01	UI	3
Relative Intensity Noise	RIN	-	-130	dB/Hz	-

- Note:**
1. X = Specified ITU Grid wavelength.
 2. Measured with a host jitter of 50 mUI peak-to-peak.
 3. Measured with a host jitter of 7 mUI RMS.

Receiver Specifications (Optical)

Parameter	Symbol	Min	Max	Unit	Notes
Sensitivity @ 9.95 Gbps	RX _{SENS1}	-	-24	dBm	1, 2
Sensitivity @ 10.7 Gbps with FEC	RX _{SENS2}	-	-25	dBm	1
Maximum Input Power	P _{MAX}	-7	-	dBm	-
Optical Center Wavelength	λ_C	1270	1600	nm	-
Receiver Reflectance	R _{rx}	-	-27	dB	-
Path Penalty at 1450 ps/nm	DP ₁	-	2.5	dB	3
Damage Threshold	-	-4	-	dBm	-
LOS Assert	LOS _A	-	-30	dBm	-
LOS De-assert	LOS _D	-26	-	dBm	-
LOS Hysteresis	-	0.5	-	dB	-

- Note:**
1. Measured at 1528-1600nm with worst ER; BER < 10⁻¹² BER, PRBS31
 2. Equivalent to -22.1 dBm OMA at ER = 9 dB.
 3. Dispersion penalty should be measured in loopback on a 1450 ps/nm fiber link.

Absolute Maximum Rating

Parameter	Symbol	Min.	Max.	Unit	Notes
Maximum Supply Voltage (5.0V)	V _{cc5}	-0.5	6.0	V	-
Maximum Supply Voltage (3.3V)	V _{cc3}	-0.5	4.0	V	-
Maximum Supply Voltage (1.8.0V)	V _{cc2}	-0.5	2.0	V	-
Storage Temperature	T _S	-40	85	°C	-
Case Operating Temperature	T _{OP}	-5	70	°C	-

General Operations

Parameter	Symbol	Min	Max	Unit	Notes
Supply Voltage (5.0V)	V _{cc5}	4.75	5.25	V	-
Supply Voltage (3.3V)	V _{cc3}	3.13	3.46	V	-
Supply Voltage (1.8.0V)	V _{cc2}	1.71	1.89	V	-
Supply Current (V _{cc5})	I _{cc5}	-	350	mA	-
Supply Current (V _{cc3})	I _{cc3}	-	400	mA	-
Supply Current (V _{cc2})	I _{cc2}	-	750	mA	-
Module Total Power	P	-	3.5	W	1
Bit Rate	BR	-	10.7	Gbps	2
Bit Error Rate	BER	-	10 ⁻¹²	-	3
Max. Supported Link Length	L _{MAX}	-	80	km	2

- Note:**
1. Maximum total power value is specified across the full temperature and voltage range.
 2. SONET OC-192, 10G Ethernet, 10G Fibre Channel, SONET OC-192 with FEC
 3. Tested with a 2³¹ – 1 PRBS

Datasheet

Transmitter Specifications (Electrical)

Parameter	Symbol	Min	Max	Unit	Notes
Input Differential Impedance	R_{in}	80	120	Ω	1
Differential Data Input Swing	$V_{in,p-p}$	120	820	mV	-
TxDisable_Disable	V_D	2.0	V_{cc}	V	2
TxDisable_Enable	V_{EN}	GND	GND+0.8	V	-
Tx Disable Assert Time	-	-	10	us	-

Note: 1. After internal AC coupling.
2. Or open circuit.

Receiver Specifications (Electrical)

Parameter	Symbol	Min	Max	Unit	Notes
Differential Data Output Swing	$V_{out,p-p}$	340	850	mV	1
Output Rise Time	t_r	-	38	ps	2
Output Fall Time	t_f	-	38	ps	2
LOS Fault	V_{LOS_fault}	$V_{cc} - 0.5$	$V_{cc_{HOST}}$	V	3
LOS Normal	V_{LOS_norm}	GND	GND + 0.5	V	3
Power Supply Rejection	PSR	See Note 3 Below			4

Note: 1. Into 100 ohms differential termination.
2. 20 – 80 %
3. Loss Of Signal is open collector to be pulled up with a 4.7k – 10kohm resistor to 3.15 – 3.6V. Logic 0 indicates normal operation; logic 1 indicates no signal detected.
4. Per Section 2.7.1. in the XFP MSA Specification

Reference Clock

Parameter	Symbol	Min	Max	Unit	Notes
Clock Differential Input Impedance	$R_{clk_{in}}$	80	120	Ω	-
Reference Clock Frequency	f_0	-	Baud/64	MHz	-
Differential Clock Input Swing	$V_{clk_{in}, pp}$	640	1660	mV	-
Reference Clock Rise/Fall Time (20%-80%)	$t_{r,f}$	200	1250	ps	-
Reference Clock Frequency Tolerance	D_f	-100	100	PPM	-

Host Board Connector Pinout

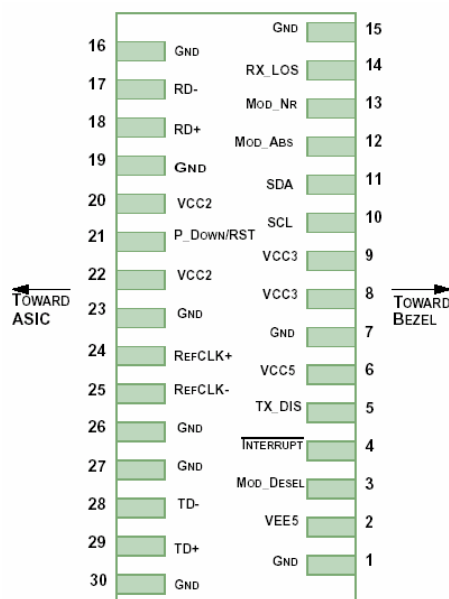

Datasheet

Pin Out Definition				
Pin	Logic	Symbol	Name/Description	Note
1	-	GND	Module Ground	1
2	-	VEE5	Optional -5.2 V power supply (not required)	-
3	LVTTTL-I	Mod_DeSel	Module De-Select; When held low allows module to respond to 2-wire serial interface	-
4	LVTTTL-O	$\overline{\text{Interrupt}}$	Interrupt (bar); Indicates presence of an important condition which can be read over the 2-wire serial interface	2
5	LVTTTL-I	TX_DIS	Transmitter Disable; Transmitter laser source turned off	-
6	-	Vcc5	+5 V Power Supply	-
7	-	GND	Module Ground	1
8	-	Vcc3	+3.3 V Power Supply	-
9	-	Vcc3	+3.3 V Power Supply	-
10	LVTTTL-I	SCL	2-Wire Serial Interface Clock	2
11	LVTTTL-I/O	SDA	2-Wire Serial Interface Data Line	2
12	LVTTTL-O	Mod_Abs	Module Absent; Indicates module is not present. Grounded in the module	2
13	LVTTTL-O	Mod_NR	Module Not Ready; MRV defines it as a logical OR between Rx_LOS and Loss of Lock in Tx/Rx.	2
14	LVTTTL-O	RX_LOS	Receiver Loss of Signal Indicator	2
15	-	GND	Module Ground	1
16	-	GND	Module Ground	1
17	CML-O	RD-	Receiver Inverted Data Output	-
18	CML-O	RD+	Receiver Non-Inverted Data Output	-
19	-	GND	Module Ground	1
20	-	Vcc2	+1.8 V Power Supply	-
21	LVTTTL-I	P_Down/RST	Power Down; When high, places the module in the lowpower stand-by mode and on the falling edge of P_Down initiates a module reset Reset; the falling edge initiates a complete reset of the module including the 2-wire serial interface, equivalent to a power cycle.	-
22	-	Vcc2	+1.8 V Power Supply	-
23	-	GND	Module Ground	1
24	PECL-I	RefCLK+	Reference Clock Non-Inverted Input, AC coupled on the host board - Not required	-
25	PECL-I	RefCLK-	Reference Clock Inverted Input, AC coupled on the host board - Not required	-
26	-	GND	Module Ground	1
27	-	GND	Module Ground	1
28	CML-I	TD-	Transmitter Inverted Data Input	-
29	CML-I	TD+	Transmitter Non-Inverted Data Input	-
30	-	GND	Module Ground	1

- Note:**
1. Module circuit ground is isolated from module chassis ground within the module.
 2. Open collector; should be pulled up with 4.7 k – 10 kohms on host board to a voltage between 3.15 V and 3.6 V.

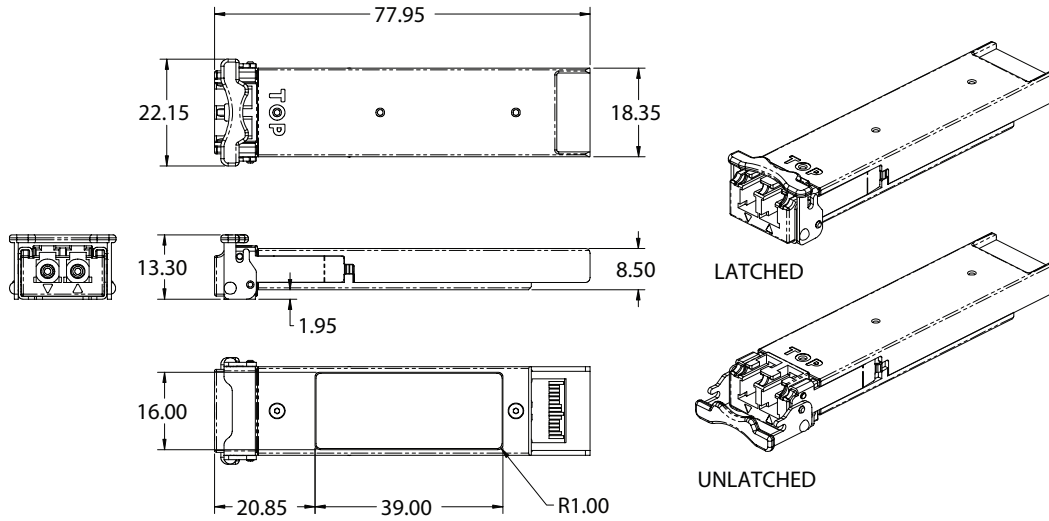
Datasheet
Mechanical Drawing

XFP Transceiver (dimensions are in mm)

λc Wavelength Guide

ITU Channel (xx)	Frequency (THz)	Wavelength (nm)	ITU Channel (xx)	Frequency (THz)	Wavelength (nm)
17	191.7	1563.863	40	194.0	1545.322
18	191.8	1563.047	41	194.1	1544.526
19	191.9	1562.233	42	194.2	1543.730
20	192.0	1561.419	43	194.3	1542.936
21	192.1	1560.606	44	194.4	1542.142
22	192.2	1559.794	45	194.5	1541.349
23	192.3	1558.983	46	194.6	1540.557
24	192.4	1558.173	47	194.7	1539.766
25	192.5	1557.363	48	194.8	1538.976
26	192.6	1556.555	49	194.9	1538.186
27	192.7	1555.747	50	195.0	1537.397
28	192.8	1554.940	51	195.1	1536.609
29	192.9	1554.134	52	195.2	1535.822
30	193.0	1553.329	53	195.3	1535.036
31	193.1	1552.524	54	195.4	1534.250
32	193.2	1551.721	55	195.5	1533.465
33	193.3	1550.918	56	195.6	1532.681
34	193.4	1550.116	57	195.7	1531.898
35	193.5	1549.315	58	195.8	1531.116
36	193.6	1548.515	59	195.9	1530.334
37	193.7	1547.715	60	196.0	1529.553
38	193.8	1546.917	61	196.1	1528.773
39	193.9	1546.119			



Datasheet

Ordering Information

Model	Description	Data Rate (Gbps)	Wavelength (nm)	Dispersion Tolerance (ps/nm)	Bail Latch Color	Distance Range (km)
XFP-DWLR08-xx*	10 GbE, 10G FC, and SONET single-mode DWDM XFP transceiver with Digital Diagnostics. 100 GHz ITU grid, C-channels 17-61	9.95 - 10.7	C-Band ITU Grid	1450	White	40 - 80

* See wavelength guide above for xx values

Regulatory and Industry Compliances

Class 1 Laser Product, complies with EN 60825-1 and 21 CFR 1040.10 except for deviations pursuant to Laser Notice No. 50. dated June 24, 2007
MSA INF-8077; Telcordia GR-468, Digital Diagnostic SFF-8472
Certified by one or more of the following agencies: TÜV, UL, CSA;
RoHS Directive; China RoHS; California RoHS Law, REACH Directive SVHC; WEEE Directive
The Quality Management System is certified to ISO 9001 by QMI-SAI Global
The Environmental Management System is in compliance with ISO 14001

Warnings

Handling Precautions: This device is susceptible to damage as a result of electrostatic discharge (ESD). A static free environment is highly recommended. Follow guidelines according to proper ESD procedures.

Laser Safety: Radiation emitted by laser devices can be dangerous to human eyes. Avoid eye exposure to direct or indirect radiation.

MRV has more than 50 offices throughout the world. Addresses, phone numbers and fax numbers are listed at www.mrv.com.
Please e-mail us at info@mrv.com or call us for assistance.

MRV Los Angeles
20415 Nordhoff Street
Chatsworth, CA 91311
800-338-5316
818-773-0900

MRV Boston
300 Apollo Drive
Chelmsford, MA 01824
800-338-5316
978-674-6800

MRV International
Business Park Moerfelden
Waldeckerstrasse 13
64546 Moerfelden-Walldorf
Germany
Tel. (49) 6105/2070
Fax (49) 6105/207-100

All statements, technical information, and recommendations related to the products herein are based upon information believed to be reliable or accurate. However, the accuracy or completeness thereof is not guaranteed, and no responsibility is assumed for any inaccuracies. Please contact MRV Communications for more information. MRV Communications and the MRV Communications logo are trademarks of MRV Communications, Inc. Other trademarks are the property of their respective holders.